

TABLE OF contents

By following the procedures in this manual, stamped engineering can be obtained economically, in a timely manner, and by an engineer familiar with SRW/MSE retaining wall design methodology. The stamped documents will indicate which designs are to be used on the project by geogrid type, soil type, site configuration case and wall height.

» INTRODUCTION

Why use this program.....	I•1
Tiered/Terraced walls.....	I•2
When not to use this program	I•2

section one: PLANNING

Planning a basic retaining wall	A•2
Planning an advanced retaining wall.....	A•3

METHODS OF SLOPE DETERMINATION

How to determine the run to rise of slope.....	A•4
» Hand level methods/two level method.....	A•4
» Construction level/transit method/paper method..	A•5
Types of slope	A•5

SKETCHING INSTRUCTIONS

HOW TO PUT YOUR RETAINING WALL ON PAPER	
Checklist: Necessary components of your sketches ...	A•6
Sample wall sketches	A•7

PHOTO INSTRUCTIONS

HOW TO PHOTOGRAPH PROPOSED SITE	
Checklist: Necessary photos of proposed site.....	A•8
Sample photos.....	A•9

SOIL SAMPLING INSTRUCTIONS

How to obtain a soil sample.....	A•10
Call before you dig: How 811 works.....	A•10

MATERIAL ESTIMATING

HOW TO CALCULATE COST OF RETAINING WALL	
Take Note: retaining wall estimation.....	A•11
Square feet of wall facing	A•12
Wall units/Pins.....	A•13
Caps/Adhesive	A•14
Leveling pad material	A•15
Drainage aggregate.....	A•15
Soil stabilization.....	A•15
Filter fabric.....	A•16
Geogrid	A•16-17
Sample retaining wall exercise	A•18
Geogrid specifications/additional information	A•19

section two: DESIGN TABLES

•DESIGN TABLES FOR SITE CONFIGURATIONS WITH WALL HEIGHTS FROM ONE RETAINING WALL UNIT TO EIGHT FEET EXPOSED HEIGHT (W/O CAP)

Table use guidelines.....	B•2-4
Design Tables.....	B•5-36

section three: INSTALLATION

Step-by-step installation instructions	C•2-16
----------------------------------------------	--------

section four: RESOURCE

Supplies.....	D•2
Site quality control/quality assurance checklist	D•3-4
Soil compaction guidelines.....	D•5-6
Water management guidelines.....	D•7
Glossary of terms	D•8-11

QUICK BOOK overview

1. PLANNING

The planning section lists the sequence of events involved in deciding to build a retaining wall. Each event (or step) is delivered with easy-to-follow instructions. The flow of this section follows along with the "Request for Stamped Engineering Form," if needed.

2. DESIGN TABLES

The first part of this section walks you through the process of determining which design table should be used for the retaining wall installation. With stamped engineering, the engineer will stamp one of the designs, determined by the information provided in the "Request for Stamped Engineering Form." (Which is completed by the builder of the wall.)

3. INSTALLATION

Time to build a retaining wall! This section will provide course-by-course instructions on building a quality retaining wall.

4. RESOURCE

The resource section provides specification information and a glossary of standard construction terms.

***5-day turnaround on stamped engineering starts once all received materials have been approved.**

INTRODUCTION

why use this program

Typically, when a homeowner or contractor discovers that their retaining wall project needs to be permitted by the local building department it is also learned that to obtain a permit they must provide engineering stamped by an engineer registered in the state of the project. The stamped engineering requirement will vary, from locality to locality. The determining factor for requiring stamped engineering is usually the exposed height of the retaining wall. Some local building departments require stamped engineering on retaining walls as short as 2' in exposed height.

THE HOME OWNER/CONTRACTOR IS THEN FACED WITH THE PROBLEMS OF:

- Finding an engineer willing to engineer a segmental (SRW) mechanically stabilized earth (MSE) retaining wall.
- Finding an engineer who is familiar with the design methodology for SRW/MSE retaining walls.
- Especially for a smaller project, obtaining the engineering at an economical cost.
- Obtaining engineering in a timely manner.



what to expect

When stamped engineering services are requested, HTS insures that the project fits the 8' and under program, that all the required information is supplied, and forwards the package to the independently licensed engineer. Then the engineer reviews the request and the customer receives:

1. Cover letter from Hardscape Technical Services.
2. Stamped cover letter from the engineer indicating the proper design table to use for construction.
3. The proper design table stamped on the site configuration (case) to be used.

Upon receipt of the stamped engineering document, you may proceed in obtaining the building permit from the local building department.

Note: The retaining wall designs on the enclosed design tables were performed using the National Concrete Masonry Association (NCMA) SRWall 3.2 retaining wall design software.

tiered or terraced retaining walls

Tiered or terraced retaining walls that do not comply with the requirements listed below can NOT use the design tables for construction. They require site specific engineering.

HOWEVER, TIERED RETAINING WALLS CAN BE CONSIDERED STAND ALONE WALLS WHEN THE FOLLOWING APPLY:

- There are no more than two walls in the tiered configuration.
- The distance between the walls is a minimum of two times the exposed height of the bottom wall, a 2 to 1 ratio.
- The grade above the walls, in between the walls, and below the walls is level and flat.
- The top wall must not be taller than the bottom wall.
- The total height (elevation change) of both walls combined can not be more than 8 feet exposed height.

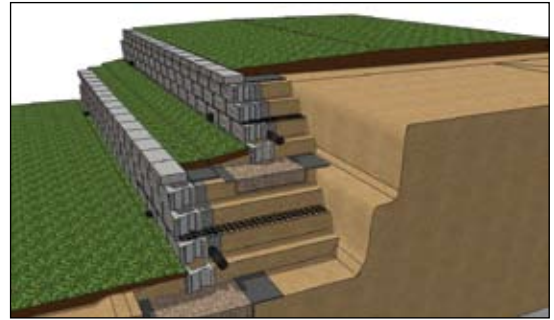

when not to use this program

- Walls with over 8' exposed height.
- Any project such as a commercial project that has specifications requiring more information than the stamped standard design is a different level of service. Examples are: the requirement of shop drawings, as built drawings, face profile drawings, hand calculations, global stability analysis, seismic analysis, certification that the wall was built to specification or site visits, etc. Such projects require site specific engineering.
- If any site conditions change, for example; water seepage, soil changes, surcharge changes, or height changes, etc., are encountered, construction of the retaining wall must be stopped and Hardscape Technical Services informed of the new conditions before the placing of ANY retaining wall units. It can then be determined if the stamped designs are appropriate or if changes are required. These conditions must be reported during excavation, before placing any retaining wall units.
- These wall designs are based on loads imposed at completion of project. Care must be taken not to overload the wall during construction, such as with heavy equipment.
- Retaining Walls with water applications such as: rivers, streams, lakes, or ponds are not considered in these tables and require site specific engineering.
- If the retaining wall will have slopes both above and below the wall, this program does not apply.



Disclaimer: The owner or the owner's representative is responsible for following the construction guidelines and is responsible for all submittals to the agency that governs. Engineering calculations are made in reliance on the product suppliers specifications. Hardscape Technical Services Inc, hereby known as HTS, is not liable if any failure or damage is caused by inaccuracy of the supplier's specifications.

section one: PLANNING

section one: PLANNING

sequence of events	A•2-3
slope angle determination guidelines	A•4-5
sketching instructions	A•6-7
photo instructions	A•8-9
soil sampling instruction	A•10
material estimating guidelines	A•11-19

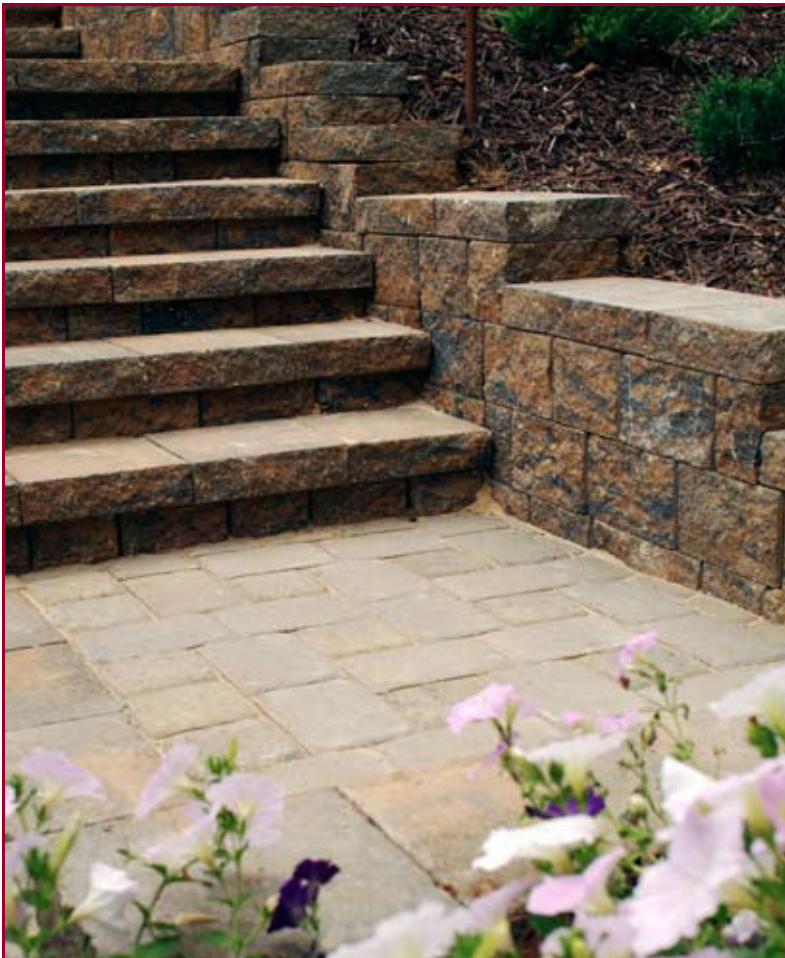

STEPS PRIOR TO THE CONSTRUCTION OF A BASIC RETAINING WALL

initial planning for a retaining wall

The sequence of events has been determined, in part, by the order of required information in the “*Stamped Engineering Request Form*.”

1. Determine the retaining wall units to be used and area of construction.
2. If there is to be a slope at the top of wall or bottom of wall, use the “*Slope Angle Determination Guidelines*” (see pages A•4-5).
3. Sketch the project using graph paper and “*Sketching Instructions*” (see pages A•6-7). Professional plans/prints should be used if available.
4. Choose the appropriate designs (soil type, case & wall height) that fit the site configuration from the tables included. If the soil friction angle is not known, it is best to be conservative and use the 26 degree soil tables.
5. Perform a materials estimate using the “*Material Estimating Guidelines*” (see page A•11-18) for hand calculation of materials needed or use the Microsoft Excel® based “*Material Estimating Spreadsheet*” found on the HTS website.
6. Contact the local building department, with copies of the above information in hand, to determine if permitting and/or stamped engineering is required.
7. If stamped engineering is NOT required, construct the retaining wall in accordance with the included “*Installation Guide*” (Section 3) and appropriate design tables.

If stamped engineering *IS* required, continue on to page A•3 and use the enclosed “*Stamped Engineering Request Form*” (found at the back of this book or download from our website - www.hardscapetech.com).

design ideas • BASIC WALLS



STEPS PRIOR TO THE CONSTRUCTION OF AN ADVANCED RETAINING WALL

When building a retaining wall that requires stamped engineering, follow steps 1-7 on page A•2 before continuing onto the steps below.

if stamped engineering is required

1. Fill out the “Stamped Engineering Request Form” found in the back of this book. Be sure to include your phone number and email address.
2. Photograph the retaining wall site using the “Photo Instructions” (page A•8).
3. If a professional soils report is not available, collect soil samples, in accordance with the “Soil Sampling Instructions” (pg A•10).
4. Send the following to Hardscape Technical Services
 - » Stamped Engineering Request Form
 - » Plan view and wall face profile sketches (pg A•6) or professional plans/prints
 - » Photographs (pg A•8). Forward as hard copies, on a CD, or email. If emailed, please note on subject line the name of the project. Send to hts@hardscapetech.com.
 - » Soil samples or professional soils report (from step 3 advanced walls).
5. If faxed or emailed documentation is acceptable for your local building authorities, the turnaround time is estimated to be no longer than five working days from the day Hardscape Technical Services receives all the required information, including payment.

design ideas • ADVANCED WALLS



**time-saving
TIP**

Rent a laser level from your local rental store for more accurate time-saving measurements.



METHODS OF SLOPE DETERMINATION HAND LEVEL & TWO LEVEL METHOD

Determine the slope angle by finding the horizontal run and the vertical rise of the slope. To determine the run to rise ratio, divide the rise into the run. Two examples of this are; (1) if a slope has a horizontal run of 4' and a vertical rise of 2' it is a 2 to 1 slope or (2) if a slope has a horizontal run of 12' and a vertical rise of 4' it is a 3 to 1 slope.

Locate a spot on the slope that is representative of the slope. There are projects where the steepness of the slope varies and you will have to determine the slope angle in more than one spot. If you want to determine the slope angle in just one spot, choose the steepest spot. The following two pages give suggestions of methods for determining the run to rise of a slope.

hand level

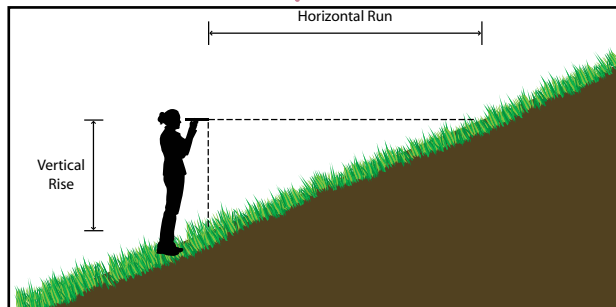

HAND LEVEL METHOD: Using a basic hand level to determine the Vertical Rise and Horizontal Run.

1. Stand on the slope, sight with the hand level, and mark the slope.
2. Measure from the ground to the middle of the hand level while it is at eye elevation to determine the rise.
3. Measure from the location of the hand level when sighting to the mark on the slope to determine the run.

two level

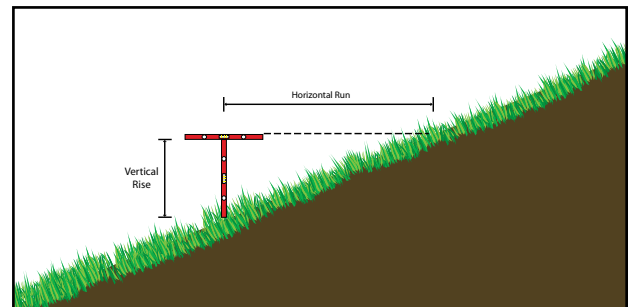

TWO LEVEL METHOD: Uses two basic levels to determine the Vertical Rise and Horizontal Run.

1. Hold one level (the longer level the better) plumb in the vertical position.
2. The length of the vertical level determines what the rise is.
3. Place the 2nd level horizontally on top of the vertical level forming a T with the top level in a level position perpendicular to the slope.
4. Sight along the top of the horizontal level and mark the spot on the slope.
5. Measure horizontally from the top of the vertical level to the spot marked on the slope to determine the run.

METHODS OF SLOPE DETERMINATION CONSTRUCTION LEVEL & PAPER METHOD

construction level

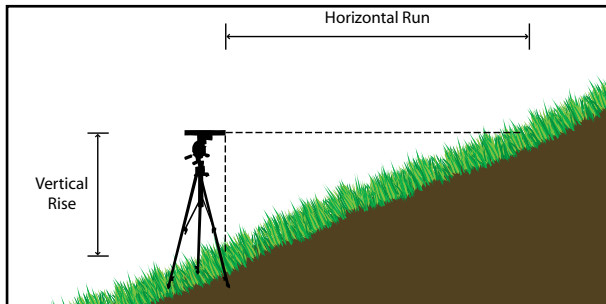

CONSTRUCTION OR TRANSIT LEVEL METHOD:
Used to determine the Vertical Rise and Horizontal Run.

1. Set up construction level or transit on the slope.
2. Measure from the ground to the middle of the construction level or transit lens to determine rise.
3. Sight through the level or transit and mark the slope.
4. Measure from the level or transit to the mark on the slope to determine run.

paper

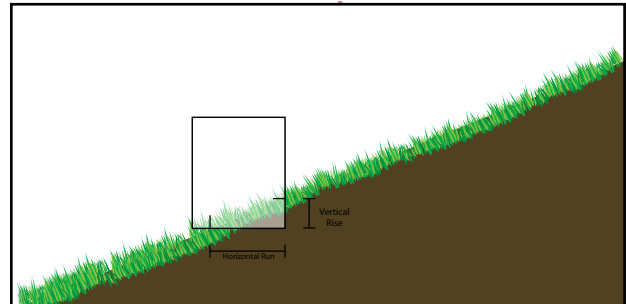

PAPER METHOD: Using a piece of paper to determine the vertical rise and horizontal run.

» **Graph paper works best, but a plain sheet of paper will do.**

1. Stand off to the side of the slope.
2. Hold the paper lightly between the forefinger and thumb so that it hangs plumb (directly vertical).
3. Hold the paper so that when you sight along the slope, the lower part of the slope will daylight at the bottom of the paper and the upper part of the slope will daylight at the side of the paper.
4. Mark on the paper where the slope daylights out of the bottom of the paper and where it daylights out of the side of the paper.
5. Measure along the bottom of the paper to determine the run of the slope and measure up the side of the paper to determine the rise of the slope. (Example; 8" run and a 2" rise = 4 to 1 slope)

SLOPE TYPES

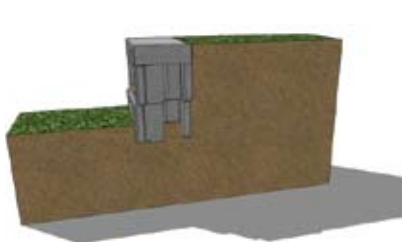

level top & bottom



slope top, flat bottom

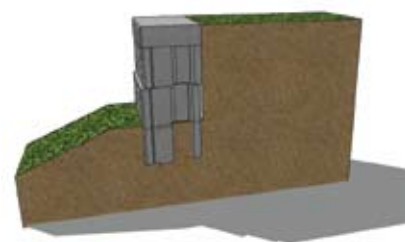

flat top, slope bottom

HOW TO PUT YOUR RETAINING WALL ON PAPER SKETCHING INSTRUCTIONS

Sketching is NOT necessary if, there are professional plans/drawings that include all of the items required for the sketching process.

If professional plans/drawings are not available, please continue with the sketching process. Included with these sketching instructions are two sample sketches of a hypothetical retaining wall project. One of the sample sketches is a plan view (from the top looking down) and the other is a wall face profile (face view of the retaining wall as if standing in front of the retaining wall).

This hypothetical project contains most of the top of wall and bottom of wall site configurations normally encountered including; slope at top of wall, surcharge at top of wall, flat at top of wall, slope at bottom of wall, and flat at bottom of wall.



helpful hints

USE GRAPH PAPER

» Sketches are most easily and most accurately drawn on graph paper. In the sample sketches the scale is 4' per square on 4x4 per square inch graph paper. Different scales can be chosen that will best fit with your retaining wall project.

USE SECTIONS

» When sketching retaining walls, they should be broken into sections. The grade or grade change of each section should be constant. The end of one section and the beginning of the next section would be at the starting point where the angle of grade change is different. A retaining wall can have from one to any number of sections.

(The clearest example of that is on the sample wall face profile sketches.)

The sample plan view and wall face profile sketches (on the following page) include all of the checklist items and should be a good "how to" reference when sketching your retaining walls. This information, accurately portrayed, is critical in determining which of the retaining wall designs to use on your project.

checklist

NECESSARY COMPONENTS OF THE SKETCHES

- ⊙ Indicate the direction North on the plan view.
- ⊙ Indicate exposed height at the beginning and end of each wall section.
- ⊙ Indicate the length of each wall section.
- ⊙ Indicate the proposed top of wall configuration for each wall section, for example; flat or positive slope. (positive slope angles up from top face of wall)
- ⊙ Indicate any surcharge (load) situations (such as; parking, driveway, building) at top of wall and distance (set back) that the surcharge is back from the face of the wall for each wall section.
- ⊙ Indicate the proposed bottom of wall configuration for each wall section, for example; flat or negative slope. (negative slope angles down from the bottom face of wall)
- ⊙ Slopes should be described by indicating the vertical rise to the horizontal run of the slope. (see page A•4)
- ⊙ When indicating the slope (example; 4 horizontal/1 vertical) on the plan view, include an arrow pointing in the down slope direction. (see the sample wall sketches on page A•7)
- ⊙ On the plan view, indicate which is the top of wall and which is the bottom of the wall.
- ⊙ If there is more than one wall, label or name each wall (For example: wall #1 etc. or West wall etc.)

SAMPLE WALL SKETCHES

» plan view sample

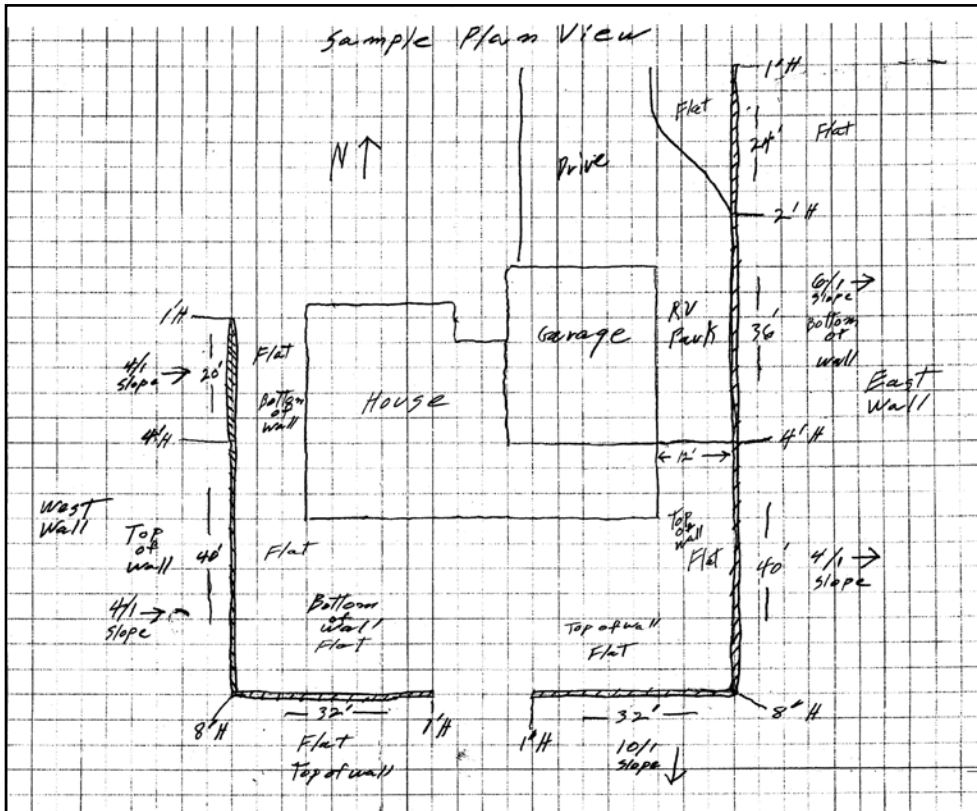

» wall face profile sample

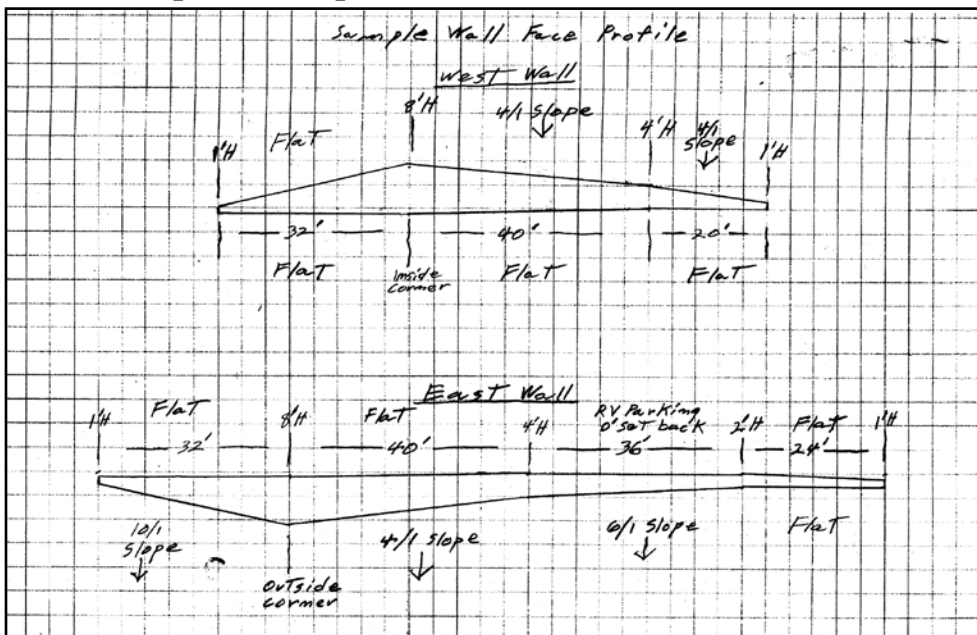

HOW TO PHOTOGRAPH PROPOSED RETAINING WALL SITE PHOTO INSTRUCTIONS

IMPORTANT:

Photos of the site are a necessary component of the information gathering process. The preferred methods of transmittal would be via email in JPEG or JPG format; on CD; or hard copies. Faxed photos are the least desirable method of transmitting photos. Email to hts@hardscapetech.com (reference your name and the project name in the email), or send photos (printed or on a CD) with the “Stamped Engineering Request Form”.

necessary elements

TO INCLUDE IN PHOTOS OF THE PROPOSED SITE

1. From the top of proposed wall site showing top of the wall conditions.
2. From the bottom of proposed wall site showing bottom of the wall conditions.
3. From the end of the proposed retaining wall site (take more than one for longer walls).
4. From the other end of the proposed retaining wall site (take more than one for longer walls).
5. Photo of any water conditions such as; seepage from the bank or pond, stream, standing water, etc., at bottom of wall.
6. Photo of any utility that might impact the retaining wall such as; utility pole or storm drain.
7. Photo of any surcharge (weight or load) that may be at the top of wall (example, pool, RV).
8. Photo of anything else that may impact the retaining wall.

potential retaining wall site



» for more example photos, refer to the following page.

section one: PLANNING

1. potential site • top

LOCATION OF THE TOP OF POTENTIAL WALL



2. potential site • bottom

LOCATION OF THE BOTTOM OF POTENTIAL WALL



3. side view • end

LOCATION OF THE END OF POTENTIAL WALL



4. side view • end

LOCATION OF THE OTHER END OF POTENTIAL WALL

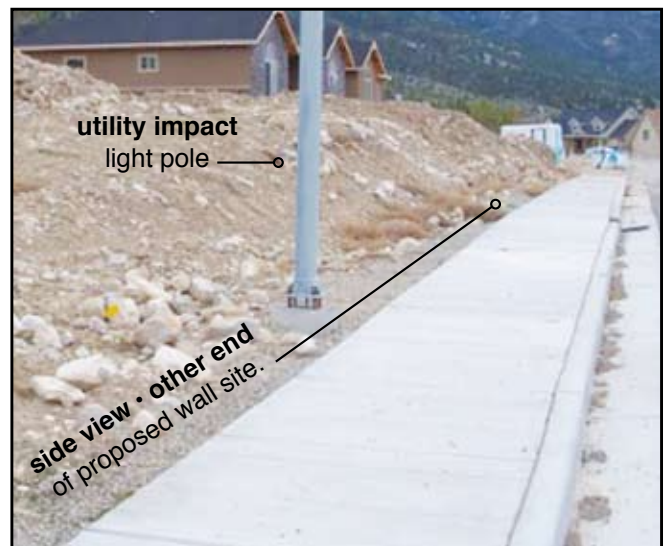

HOW TO OBTAIN A SOIL SAMPLE

SOIL SAMPLING INSTRUCTIONS

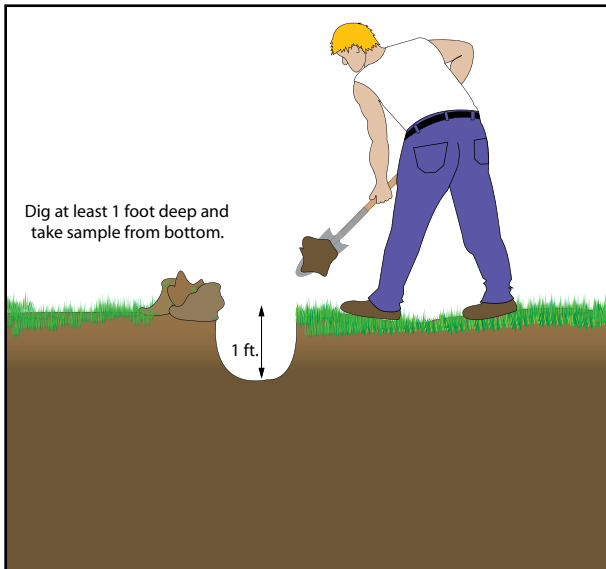

IF, a soils report is available, please forward that with the “Stamped Engineering Request Form”.

IF NOT, use this procedure to obtain the soil sample to be forwarded with the “Stamped Engineering Request Form”.

Determine the location of the retaining wall.

1. Dig a hole at least one foot deep and take the sample from the bottom of the hole.
2. If one foot deep doesn't get below the topsoil, dig until through the topsoil.
3. Make sure that the soil sample represents the site soils.
4. Place soil sample in a quart zip lock bag (or the bag provided) and send with the “Stamped Engineering Request Form”.

call before you dig!

Before beginning wall construction it is important to ensure that there are no underground hazards that could cause delays, disruptions or injury. Electric power lines, natural gas pipelines, communications lines, and other utility services could be within a few feet of the surface. Digging into an underground electric line can cause power outages and injury from shock or electrocution. A damaged gas pipeline or service to a house or business can create an explosion hazard that potentially endangers both persons and property.

In 1996 the United States Department of Transportation's Office of Pipeline Safety developed a national damage prevention and safety campaign now known as “Dig Safely”. Since that time, the Dig Safely campaign has been used throughout the country to address damage prevention and worker safety. It is not difficult to find the right agency to contact in your area.

» **Go to www.digsafely.com and click on “One Call Contacts” for a list of who to call first in your area before you dig.**

ALTERNATELY YOU CAN USE THE 8-1-1 PROGRAM

how 8-1-1 works

One phone call to 811 starts the process to get your underground utility lines marked for free.

- When you call 811 from anywhere in the country, your call will be routed to your local One Call Center.
- Local One Call Center operators will ask you for the location of your digging job and route your call to affected utility companies.
- Your utility companies will then send a professional locator to your location to mark your lines within a few days. Once your underground lines have been marked, you will know the approximate location of your utility lines and can dig safely.

Go to www.call811.com for further information.

HOW TO CALCULATE THE COST OF YOUR RETAINING WALL MATERIAL ESTIMATING

Accurate estimating of material quantities is an important part of a project. Under-estimating will cause extra delivery charges or wasted time picking up the additional materials needed. If production is stopped or interrupted while waiting for materials, labor costs may rise. Over-estimating of materials will result in the payment for materials not needed, will cost in labor to remove the materials from the project, and will take up space if the materials have to be stored until the next project. Retaining wall proj-

ects tend to end up slightly different than first envisioned. The careful planning required for an accurate material estimate can help alleviate that situation. The sketches required for the engineering will be invaluable in estimating the materials.

The materials that will be addressed in this estimating guide will be the retaining wall unit, the cap, adhesive, leveling pad materials, drainage aggregate, SS5 Soil Stabilization Fabric, NW4.5 Filter Fabric, and Geogrid.

IMPORTANT!

TIPS TO ACCURATE ESTIMATING

- Estimate one wall section at a time as shown on your plan view and/or face profile sketches.
- Round up numbers after quantities of all sections are added together.
- The following quantities do not take breakage, cutting loss, swell of uncompacted soil, or other “Fluff Factors” into account. Soils can be “fluffed” as high as 30%.

» take note

CONSISTENT ITEMS IN RETAINING WALL ESTIMATION

- Maytrx® retaining wall system consists of four different size units. An equal number of each unit is usually used. All units are 6" high. The unit widths are 8", 10", 10" and 12". The average width is 10" and the average sq. ft. of face per unit is .4167 sq. ft.
- When the retaining wall steps up or down on either the top or bottom of wall, add 1/2 course of retaining wall units (example: if wall section is 12 units long, add one course of 6 units).
- Maytrx® caps are 12" or 1 lineal foot. Each lineal foot of retaining wall requires one cap. (Producers may supply different sized caps. Check with your supplier to verify cap size.)
- Whenever the top of wall steps up or down, add 1/2 cap.
- Each tube of 10.5 oz. adhesive should fasten 7 caps. Each 29 oz. tube should fasten 20 caps.
- The 6" x 30" leveling pad requires 1.25 cu. ft. of material for every lineal foot of leveling pad.
- Each square foot of wall face requires 1.0846 cu. ft. of drainage aggregate that is placed one foot thick behind the retaining wall units and placed in the cores and in between the retaining wall units.

time-saving TIP

For faster, easier estimating log onto www.hardscapetech.com for downloadable material estimating spreadsheets.

additional information

- The material quantities are not represented to be exact, but should be close if the finished retaining wall ends up as originally planned.

- When you first start to use this material estimation method, it would be wise to check the quantities against your usual method of estimating materials to check the accuracy of this method.

- There has been no provision for waste, breakage, or other contingencies that would change material quantities in this material estimating procedure.

- Hardscape Technical Services assumes no responsibility for the accuracy of the material quantities resulting from the use of this estimation method. The responsibility for accuracy of quantities is the user's sole responsibility.

HOW TO CALCULATE THE COST OF YOUR RETAINING WALL MATERIAL ESTIMATING

step 1 >> SQUARE FEET OF WALL FACING

- a. Determine the total height of each end of the wall section using the accompanying design tables. The wall heights are shown directly under the design. Choose the design by picking the exposed wall height that is the same as the height of your proposed retaining wall or, if there is not an exact match choose the next taller design. Then for estimating purposes choose the total height of the design that is indicated below the design. In most cases there will be at least one block buried. Don't forget to include that in your height determination. Again, the total height without the cap is located below the wall in the design tables.
- b. Add the total heights (1•a above) of the two ends of the wall section together and divide by 2 to determine the average height of the wall section.

$$\frac{\text{beginning total hgt}}{\text{beginning total hgt}} + \frac{\text{end total hgt}}{\text{end total hgt}} = \frac{\text{beginning total hgt} + \text{end total hgt}}{\text{beginning total hgt} + \text{end total hgt}} \div 2 = \frac{\text{beginning total hgt} + \text{end total hgt}}{2} = \text{average wall hgt}$$

- c. Multiply the average height (1•b above) by the lineal footage of the wall section to determine the number of square feet of wall facing.

$$\frac{\text{average hgt}}{\text{average hgt}} \times \frac{\text{lineal footage}}{\text{lineal footage}} = \frac{\text{average hgt} \times \text{lineal footage}}{\text{lineal footage}} = \text{sq. ft. wall face}$$

- d. If the wall section steps at either the top of wall or bottom of wall, add 1/2 course of block. Do this by dividing the length of the wall section by 2. Multiply that result by .5. Then add that result to the square feet (1•c above) of wall facing.

$$\frac{\text{wall length}}{\text{wall length}} \div 2 = \frac{\text{wall length}}{2} \times .5 = \frac{\text{wall length}}{4} = \text{additional sq. ft.}$$

$$\frac{\text{sq. ft wall face}}{\text{sq. ft wall face}} + \frac{\text{additional sq. ft.}}{\text{additional sq. ft.}} = \frac{\text{sq. ft wall face} + \text{additional sq. ft.}}{\text{additional sq. ft.}} = \text{total sq. ft.}$$

HOW TO CALCULATE THE COST OF YOUR RETAINING WALL MATERIAL ESTIMATING

step 2 >> MAYTRX® WALL UNITS

- a. Maytrx® units average .4167 sq. ft. per unit. To get the number of units divide the total square feet by .4167 sq. ft. The number of units will be evenly divided between a, b, x, and y units.

$$\frac{\text{total face square footage}}{\text{total face square footage}} \div .4167 = \frac{\text{\# of retaining wall units}}{\text{\# of retaining wall units}}$$

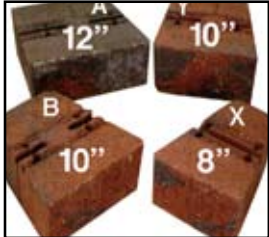

step 3 >> MAYTRX® PINS

- a. Divide the lineal ft. of the wall section by .8333 to obtain the number of top course units.

$$\frac{\text{lin. ft. of section}}{\text{lin. ft. of section}} \div .8333 = \frac{\text{\# of top course units}}{\text{\# of top course units}}$$

- b. Subtract the number of top course units for the number of wall units (2•a above) to obtain the net number of wall units.

$$\frac{\text{\# of wall units}}{\text{\# of wall units}} - \frac{\text{\# of top course units}}{\text{\# of top course units}} = \frac{\text{net \# of wall units}}{\text{net \# of wall units}}$$

- c. Multiply the net number of wall units (3•b above) by 2 to obtain the number of pins.

$$\frac{\text{net \# of wall units}}{\text{net \# of wall units}} \times 2 = \frac{\text{\# of pins}}{\text{\# of pins}}$$

HOW TO CALCULATE THE COST OF YOUR RETAINING WALL MATERIAL ESTIMATING

step 4 >> MAYTRX® CAPS



*If another size cap is used this number may not be valid. Check with your local retailer to see what is available in your area.

- a. The lineal footage of the wall section equals the number of caps needed.

$$\frac{\text{lineal feet}}{\text{\# of caps}} = \text{\# of caps}$$

- b. Add 1/2 cap for each 6" elevation change at top of wall.

$$\frac{\text{tall end hgt}}{\text{short end height}} - \frac{\text{short end height}}{\text{short end height}} = \frac{\text{elevation change}}{\text{short end height}}$$

$$\frac{\text{elevation change}}{\text{short end height}} \div .5 = \frac{\text{\# of steps in wall}}{\text{\# of steps in wall}}$$

$$\frac{\text{\# of steps in wall}}{\text{\# of steps in wall}} \div 2 = \frac{\text{additional caps}}{\text{additional caps}}$$

$$\frac{\text{\# of caps (from a)}}{\text{\# of caps (from a)}} + \frac{\text{additional caps}}{\text{additional caps}} = \frac{\text{total \# caps}}{\text{total \# caps}}$$



step 5 >> SRW ADHESIVE

- a. Divide the number of caps (3•b above) by 7 to determine the number of 10.5 oz. tubes of SRW Products® adhesive required.

$$\frac{\text{total \# of caps}}{\text{total \# of caps}} \div 7 = \frac{\text{\# of 10.5 oz. tubes}}{\text{\# of 10.5 oz. tubes}}$$

- b. Divide the number of caps (3•b above) by 20 to determine the number of 29 oz. tubes of SRW Products adhesive required.

$$\frac{\text{total \# of caps}}{\text{total \# of caps}} \div 20 = \frac{\text{\# of 29 oz. tubes}}{\text{\# of 29 oz. tubes}}$$

HOW TO CALCULATE THE COST OF YOUR RETAINING WALL MATERIAL ESTIMATING

step 6 >> LEVELING PAD MATERIALS

- a. Multiply the lineal feet of the wall section by 1.25 to determine the number of cubic feet.

$$\frac{\text{lineal ft. of section}}{\text{lineal ft. of section}} \times 1.25 = \frac{\text{\# of cubic ft.}}{\text{\# of cubic ft.}}$$

- b. Divide the number of cubic feet by 27 to determine the number of cubic yards of leveling pad material.

$$\frac{\text{\# of cubic ft.}}{\text{\# of cubic ft.}} \div 27 = \frac{\text{\# of cubic yds}}{\text{\# of cubic yds}}$$

step 7 >> DRAINAGE AGGREGATE

- a. Multiply the total face square feet of wall facing (1•d above) by 1.046 to find the cubic feet of drainage aggregate and core fill material.

$$\frac{\text{total face sq. ft.}}{\text{total face sq. ft.}} \times 1.046 = \frac{\text{\# of cubic ft.}}{\text{\# of cubic ft.}}$$

- b. Divide the number of cubic feet by 27 to determine the number of cubic yards of drainage aggregate material.

$$\frac{\text{\# of cubic ft.}}{\text{\# of cubic ft.}} \div 27 = \frac{\text{\# of cubic yds}}{\text{\# of cubic yds}}$$

step 8 >> SRW SOIL STABILIZATION FABRIC*

- a. The lineal feet of the wall section equals the lineal feet of SRW SS5 soil stabilization fabric needed

$$\frac{\text{lineal ft. of wall section}}{\text{lineal ft. of wall section}} = \frac{\text{lineal ft. of fabric}}{\text{lineal ft. of fabric}}$$



Product APPROVED!

Look for the "seal of approval" on HTS approved products for the HTS Engineering Program.

* Optional, but recommended.



HOW TO CALCULATE THE COST OF YOUR RETAINING WALL MATERIAL ESTIMATING

step 9 >> SRW FABRIC FILTER*

* Optional, but recommended.

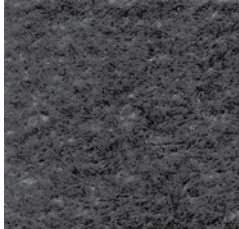

- a. The lineal feet of the wall section equals the lineal feet of SRW NW4.5 filter fabric needed.

$$\frac{\text{lineal ft of wall section}}{\text{lineal ft of fabric}} = \frac{\text{lineal ft of fabric}}{\text{lineal ft of fabric}}$$

step 10 >> SRW GEOGRID

- a. Use the design tables included in this booklet, as indicated by the engineer (for stamped engineering) or that fit your project, to determine the designs to be used. There may be more than one height design used per wall section.
- b. If the wall section is the same height at both ends only one design is required. The square yards of geogrid per lineal foot for each design height is located just below the design in the design tables. Multiply the square yards of geogrid by the lineal feet of the wall section to determine the amount of square yards of geogrid required for that wall section.

$$\frac{\text{sq. yards of geogrid}}{\text{lin. ft. of wall section}} = \frac{\text{sq. yards of geogrid}}{\text{sq. yards/section}}$$

- c. If the wall section has a different height on each end, when estimating and constructing your retaining wall it may make sense to skip some designs. For example, if a wall section begins with an exposed height of 2' and ends with an exposed height of 8', it may make sense to use only the 4', 6', and 8' exposed height designs to simplify the geogrid placement during construction. In that case, the 4' design would be used from the 2' height to the 4' height, the 6' design would be used between the 4' and 6' heights, and the 8' design would be used between the 6' and 8' heights. Also in that case, if the wall steps up at the bottom of wall, the bottom layer of geogrid should be moved up to the next course of block and not eliminated until the 2nd from the bottom layer of geogrid is encountered. The reason for skipping designs is so that the geogrid layers and depths don't have to be changed at every step in the wall. It may be wise to experiment with different design heights to determine the best lengths to use each design. If too many designs are used in a wall section the geogrid placement becomes complicated.
- d. If the wall section has a different height at each end and more than one design is to be used, the lineal feet of each design within the wall section must be determined as follows:

1. Subtract the short end of exposed wall section height from the tall end of exposed wall section height to determine the amount of change or difference in exposed wall height.

$$\frac{\text{tall end hgt}}{\text{short end hgt}} = \frac{\text{wall hgt difference}}{\text{wall hgt difference}}$$



Product APPROVED!

Look for the "seal of approval" on HTS approved products for the HTS Engineering Program.

HOW TO CALCULATE THE COST OF YOUR RETAINING WALL MATERIAL ESTIMATING

step 10 (continued) >> SRW GEOGRID

$$\frac{\text{wall hgt difference}}{\text{wall hgt difference}} \div .5 = \frac{\text{# of courses}}{\text{# of courses}}$$

$$\frac{\text{lineal feet}}{\text{lineal feet}} \div \frac{\text{# of courses}}{\text{# of courses}} = \frac{\text{lineal ft. per step}}{\text{lineal ft. per step}}$$

$$\frac{\text{lineal ft. per step}}{\text{lineal ft. per step}} \times \frac{\text{# of courses}}{\text{# of courses}} = \frac{\text{lineal ft. of design}}{\text{lineal ft. of design}}$$

$$\frac{\text{geogrid sq. yd./lineal ft.}}{\text{geogrid sq. yd./lineal ft.}} \times \frac{\text{lineal ft. of design}}{\text{lineal ft. of design}} = \frac{\text{sq. yds./design hgt.}}{\text{sq. yds./design hgt.}}$$

2. Divide the exposed wall height difference (10•d•1 above) by .5 to determine the number of courses of block to achieve the wall height difference. In the event that the result is not a whole number, round up to the next highest number of block courses.

3. Divide the wall section lineal feet by the number of block courses (10•d•2 above) of the change or difference in design height to determine the lineal feet of each step in the wall section.

4. Multiply the lineal feet per step (10•d•3 above) in the wall section by the number of courses (10•d•2 above) that you are using each design for to determine the lineal feet that each design height will be used in the wall section. (Example; if you are using the 4' design for the heights between 2' and 4' you would multiply by 4 because it takes 4 courses of 6" high block to equal 2 feet of height change or difference)

5. The geogrid square yard per lineal foot for each design height is located just below the design in the design tables. Multiply the geogrid square yard per lineal foot by the lineal feet of design (10•d•4 above) that a particular design height is to be used in the wall section to determine the amount of square yards of geogrid required for the design height used. Do this for each design height that is used in the wall section.

6. Add the square yards of geogrid required for each design height together to determine the total square yards of geogrid required for the wall section.

step 11 >> TOTALS

When the above process has been completed for all wall sections, add the quantities of each item together to determine the total materials needed for the retaining wall project.

wall section	Sq. Ft. of wall facing	Maytrx® unit	Maytrx® cap	pins	SRW adhesive	leveling pad materials	drainage aggregate	stabilization fabric	geogrid
1									
2									
3									
4									
5									
totals									

RETAINING WALL EXERCISE SAMPLE WALL EXERCISE

The following is a sample retaining wall with the project parameters and the material quantities shown so that a trial run can be made to see if all of the steps for material estimation are being followed. If the quantities are different than the quantities below, all of the steps were not correctly followed.

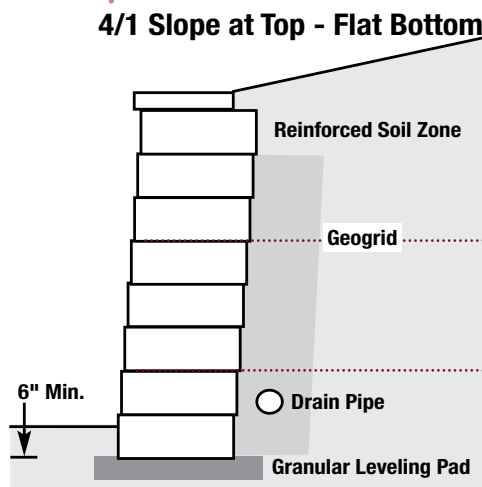

wall section	beginning exposed hgt	ending exposed hgt	lineal ft.
1	2'0"	8'0"	18'
2	8'0"	8'0"	24'
3	8'0"	2'0"	36'

This sample retaining wall consists of 3 sections. The soil is a 26 degree soil. There is a 4/1 slope at the top of wall. It is flat at the bottom of wall. Section 1 steps at the top of wall. Section 2 does not step. Section 3 steps at the bottom of the wall. For the wall sections that step from 2' exposed height to 8' exposed height, use the 4', 6', and 8' exposed height designs from the tables to obtain the geogrid lengths to use in this trial run. Using the "Material Estimating" hand calculations or spreadsheet calculations (available for download at www.hardscapetech.com), fill in the following table with the proper material estimates. (See answers below)

wall section	Sq. Ft. of wall facing	Maytrx® unit	Maytrx® cap	pins	SRW adhesive	leveling pad materials	drainage aggregate	stabilization fabric	geogrid
1									
2									
3									
totals									

money-saving TIP

The tallest section of wall is 8' in height. You may want to chose a design table that used the same geogrid throughout, saving you from buying more than one type of geogrid.

SAMPLE RETAINING WALL ANSWERS

ITEM	QUANTITY NEEDED
1. square ft. of wall facing	515
2. number of Maytrx® units	1235
3. number of pins	2282
4. number of Maytrx® cap units	84
5. number of 10.5 oz. adhesive	12
6. or, number of 29 oz. adhesive	4
7. cubic yards of leveling pad material	3.61
8. cubic yards of drainage aggregate	20.67
9. lineal ft. of soil stabilization fabric	78
10. lineal ft. of filter fabric	78
11. sq. yards of geogrid	238.33

GRID PROPERTIES AND ADDITIONAL INFORMATION GEOGRID SPECIFICATIONS

SRW UNIVERSAL GEOGRID



grid property	value
aperture size (average)	.75" x .75"
creep limited strength	737 lbs./ft.
ultimate strength	1175 lbs./ft.
long term design strength (LTDS)	620 lbs./ft.

SRW 3 SERIES GEOGRID



grid property	value
aperture size (average)	.75" x .75"
creep limited strength	1259 lbs./ft.
ultimate strength	1940 lbs./ft.
long term design strength (LTDS)	1041 lbs./ft.

ADDITIONAL INFORMATION

- SRW Universal Geogrid is supplied in 4' x 45', 4' x 50' and 6' x 50' rolls. Check with your supplier to determine what is inventoried.
- SRW 3 Series Geogrid is supplied in 4' x 50', 6' x 50', 6' x 150' and 12' x 150' rolls. Check with your supplier to determine what is inventoried.
- SRW SS5 Soil Stabilization Fabric is provided in 4' x 50', 4' x 100', 6' x 50', and 6' x 100' rolls.
- SRW NW4.5 Filter Fabric is provided in 3' x 100', 3' x 300', 4' x 100', 4' x 300', 6' x 100', 6' x 300', 12.5' x 360', and 15' x 360' rolls.
- Download the Microsoft Excel® material estimating spreadsheet and instructions of use on the HTS website to use instead of the hand calculation process if desired.

ABOUT SRW GEOGRID

Universal and 3 Series Geogrid are bi-directional geogrids, meaning they provide the same tensile strength in two directions and can be installed either perpendicular or parallel to the wall.

They are composed of high molecular weight, high tenacity multifilament polyester yarns that are woven into a stable network placed under tension. The high strength polyester yarns are coated with a PVC material.

Geogrid is typically used for soil reinforcement applications such as retaining walls, steepened slopes, embankments, sub-grade stabilization, embankments over soft soils and waste containment applications.

section two: DESIGN TABLES

section two: DESIGN TABLES

table use guidelinesB•2-4

TABLES

- 26 soil B•5-11
- 28 soil B•12-18
- 30 soil B•19-27
- 32 soil B•28-36

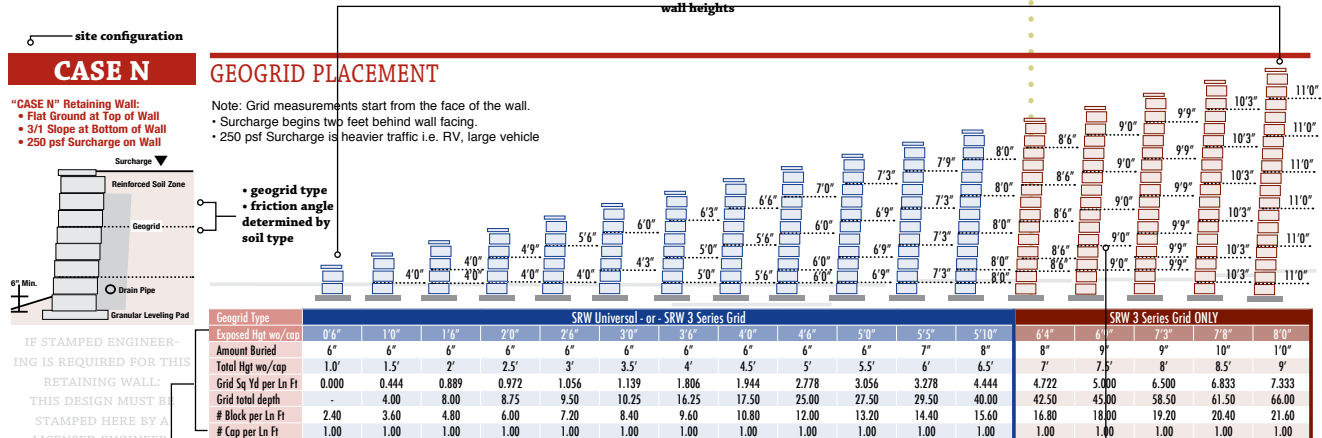
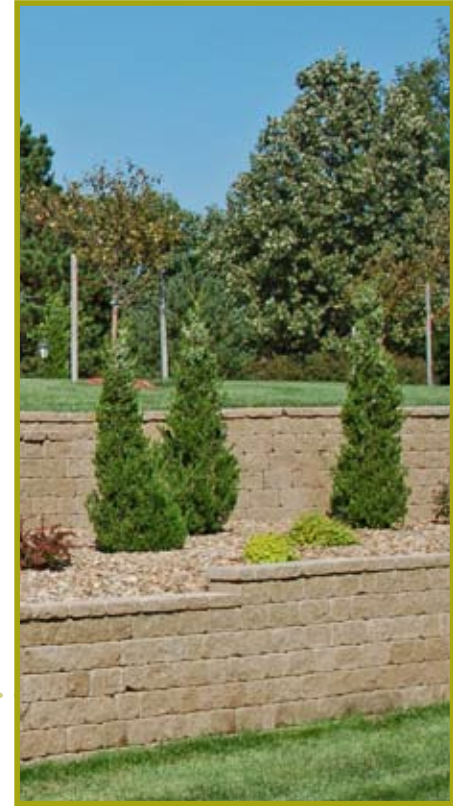

IF STAMPED ENGINEERING IS REQUIRED FOR THIS RETAINING WALL, THIS DESIGN MUST BE STAMPED HERE BY A LICENSED ENGINEER

Geogrid: SRW Universal 620 LTDS or SRW 3 Series 1041 LTDS • Block Dimensions: 6"(H) x 8", 10" OR 12" (W) x 10"(D) • Avg Cover: .4167 Sq. Ft.
 If used without the stamped engineering, the final determination of the suitability of the contemplated use, and its manner of use, are the sole responsibility of the user, and the user expressly releases HTS, SRW and retaining wall unit supplier of any and all liability that might arise as a result. These designs have been performed with National Concrete Masonry Association (NCMA) software and have been analyzed for the appropriate factors of safety. © 2009 Hardscape Technical Services • Maytrx® is a registered trademark of Maytrx Premier Stone System.

26 DEGREE SOIL for walls up to 8'

Maytrx® Block • SRW Accessories



geogrid placement and geogrid length

- a. exposed wall height, w/o cap
- b. amount buried, block at the base of wall
- c. total wall height, w/o cap
- d. square yards of geogrid per lineal foot of wall
- e. total depth of all geogrid layers
- f. number of block per lineal foot of wall
- g. number of caps per lineal foot of wall

DESIGN TABLES

TABLE USE GUIDELINES

understanding design tables

1. Soil types; these are the main categories. The soil types are designated by the Internal Angle of Friction. The Internal Angle of Friction is a numerical indication, in degrees, of the strength of the soil. For the purposes of this Standardized Engineering Program the friction angles used are 26, 28, 30 and 32 degrees.
2. Site configuration; within the soil type the designs are further separated by site configuration. The different site configurations are indicated by Case A, Case B, etc. The differences in the Cases are the wall configurations. The Cases are determined by such things as surcharge or loading at the top of wall or slopes at the bottom of wall or top of wall. (100 lb. surcharge is light traffic, i.e. car or pickup, & 250 lb. surcharge is heavier traffic, i.e. motor home or large vehicle)
3. Height of wall; within each site configuration case are different exposed wall height designs. The designs range from one unit exposed height up to 8'0" exposed height, depending on the site configuration case. The wall heights are shown directly under the design. Choose the design by picking the exposed wall height that is the same as the height of your proposed retaining wall or, if there is not an exact match choose the next taller design. Then for estimating purposes choose the total height of the design that is indicated below the design.
4. Beneath each design are numbers indicating the following;
 - a. Exposed Height, without the cap
 - b. Amount Buried, at the base of the wall
 - c. Total Wall Height, without the cap
 - d. Square Yards of geogrid per lineal foot of wall
 - e. Total Depth of all geogrid layers (example; if the design has 2 layers of geogrid embedded 4', the total depth would be 8')
 - f. Number of Block per lineal foot of wall
 - g. Number of Caps per lineal foot of wall

<<
 refer to
 example
 table
 on page
 B•1

»» **FOR STAMPED ENGINEERING:**

The engineer that HTS links you with will indicate which Geogrid Type, Soil Type, and Case is appropriate for your project.

DESIGN TABLES

TABLE USE GUIDELINES

without or before requesting engineering

For determining Geogrid type, Soil Type, and Case for estimating costs before requesting stamped engineering or for walls that are low enough in height that they do not require a permit or stamped engineering, the procedure is as follows:

GEOGRID TYPE

- For walls up to 6' exposed height either SRW Universal or SRW 3 Series geogrid may be used. The type used may be determined by which type is most economical or which type your dealer has in stock.
- For walls that are over 6' exposed height and up to 8' exposed height, only SRW 3 Series geogrid may be used.

SOIL TYPE

Use the soil classification and approximate friction angle information below.

- Chart A shows the symbols for the different soil types.
- Use the Unified Soil Classification System table (Chart B) to determine your soil type.

continued on next page »

1st and/or 2nd Letters	Definition	2nd Letter	Definition
G	Gravel	P	Poorly Graded (uniform particle sizes)
S	Sand	W	Well Graded (diversified particle sizes)
M	Silt	H	High Plasticity
C	Clay	L	Low Plasticity
O	Organic		

Major Divisions		USCS Symbol	Typical Descriptions	
COURSE GRAINED SOILS More than 50% of the material is larger than the #200 (.075 mm) sieve	GRAVELS More than 50% of the coarse fraction is larger than the #4 (4.75 mm) sieve	CLEAN GRAVELS	GW	WELL GRADED GRAVELS, GRAVEL-SAND MIXTURES WITH LITTLE OR NO FINES
			GP	POORLY-GRADED GRAVELS, GRAVEL-SAND MIXTURES WITH LITTLE OR NO FINES
		GRAVELS with over 12% fines	GM	SILTY GRAVELS, GRAVEL-SILT-SAND MIXTURES
			GC	CLAYEY GRAVELS, GRAVEL-SAND-CLAY MIXTURES
	SANDS More than 50% of the coarse fraction is smaller than the #4 sieve	CLEAN SANDS	SW	WELL-GRADED SANDS, SAND-GRAVEL MIXTURES WITH LITTLE OR NO FINES
			SP	POORLY-GRADED SANDS, SAND-GRAVEL MIXTURES WITH LITTLE OR NO FINES
		SANDS with over 12% fines	SM	SILTY SANDS, SAND-GRAVEL-SILT MIXTURES
			SC	CLAYEY SANDS, SAND-GRAVEL-CLAY MIXTURES
FINE GRAINED SOILS More than 50% of the material is smaller than the #200 sieve	SILTS AND CLAYS Liquid limit less than 50	ML	INORGANIC SILTS & VERY FINE SANDS, SILTY OR CLAYEY FINE SANDS, CLAYEY SILTS WITH SLIGHT PLASTICITY	
		CL	INORGANIC CLAYS OF LOW TO MEDIUM PLASTICITY, GRAVELLY CLAYS, SANDY CLAYS, SILTY CLAYS, LEAN CLAYS	
		OL	ORGANIC SILTS, ORGANIC SILTY CLAYS OF LOW PLASTICITY	
	SILTS AND CLAYS Liquid limit greater than 50	MH	INORGANIC SILTS, MICACEOUS OR DIATOMACEOUS FINE SAND OR SILT	
		CH	INORGANIC CLAYS OF HIGH PLASTICITY, FAT CLAYS	
		OH	ORGANIC CLAYS & ORGANIC SILTS OF MEDIUM-TO-HIGH PLASTICITY	
HIGHLY ORGANIC SOILS		PT	PEAT, HUMUS, SWAMP SOILS WITH LIGHT ORGANIC CONTENTS	

DESIGN TABLES

TABLE USE GUIDELINES

- c. Chart C shows particle sizes for different soil types. National Concrete Masonry Association guidelines indicate that rocks/stones over 4” in diameter should not be used in the retaining wall backfill. Bigger diameter pieces in the backfill make compaction problems.
- d. Choose the Friction Angle of the soil from Chart D. Be conservative. Choose the friction angle at the bottom of the range, i.e. 26° instead of 28°. If there is any question about soil type, it is wise to choose the 26° soils. It is best not to under-estimate the cost of the retaining wall. Also, the cost difference on retaining walls of these heights is not great enough to risk an under-designed retaining wall.

Inches	US Standard Sieve #	Particle Size
Over 8”		Boulder
8” to 3”		Cobble
3” to 3/4”		Gravel (course)
3/4” minus	4	Gravel (fine)
-	4 to 10	Sand (course)
-	10 to 40	Sand (medium)
-	40 to 200	Sand (fine)
-	200 & over	Silt or Clay
1 micron = .001”		

Soil Description	USCS Classification	Wall Backfill Use Range	Friction Angle Range
Sand, Gravel, Stone	GW, GP, GM, GC, SW, SP	Good	30° - 34°
Silty Sands, Clayey Sands	SM, SC	Moderate	28° - 30°
Silts, Low Plasticity Clays	ML, CL, OL	Difficult	26° - 28°
High Plasticity Silts & Clays, Organics	CH, MH, OH, PT	Bad	0° - 26°

helpful hints

» **CHOOSING THE CORRECT DESIGN TABLE**

Using your plans or the sketches made by following the Sketching Instructions, choose the Case(s) that is/are applicable to the proposed retaining wall. If the retaining wall configuration does not exactly match one of the cases use the next higher case. For example, if the grade is not flat at the top of wall but there will be less slope than a 4/1 slope, choose the 4/1 slope design. Always choose the more conservative option.

» **CHOOSING THE CORRECT HEIGHT**

Choose the correct exposed height design. The designs will show how many layers of geogrid are required, the length that each layer is embedded into the soil, and the course of block that the geogrid is placed on top of. Below each design are numbers that will be needed in the material estimation process.

» **MULTI-HEIGHT RETAINING WALLS**

If the wall section has a different height on each end, when estimating and constructing your retaining wall it may make sense to skip some designs. For example, if a wall section begins with an exposed height of 2’ and ends with an exposed height of 8’, it may make sense to use only the 4’, 6’, and 8’ exposed height designs to simplify the geogrid placement during construction. In that case, the 4’ design would be used from the 2’ height to the 4’ height, the 6’ design would be used between the 4’ and 6’ heights, and the 8’ design would be used between the 6’ and 8’ heights. Also in that case, if the wall steps up at the bottom of wall, the bottom layer of geogrid should be moved up to the next course of block and not eliminated until the 2nd from the bottom layer of geogrid is encountered.

CASE A

- "CASE A" Retaining Wall:**
- Flat Ground at Top of Wall
 - Flat Ground at Bottom of Wall
 - No Surcharge on Wall

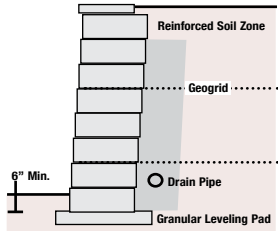

IF STAMPED ENGINEERING IS REQUIRED FOR THIS RETAINING WALL: THIS DESIGN MUST BE STAMPED HERE BY A LICENSED ENGINEER.

GEOGRID PLACEMENT

Note: Grid measurements start from the face of the wall.

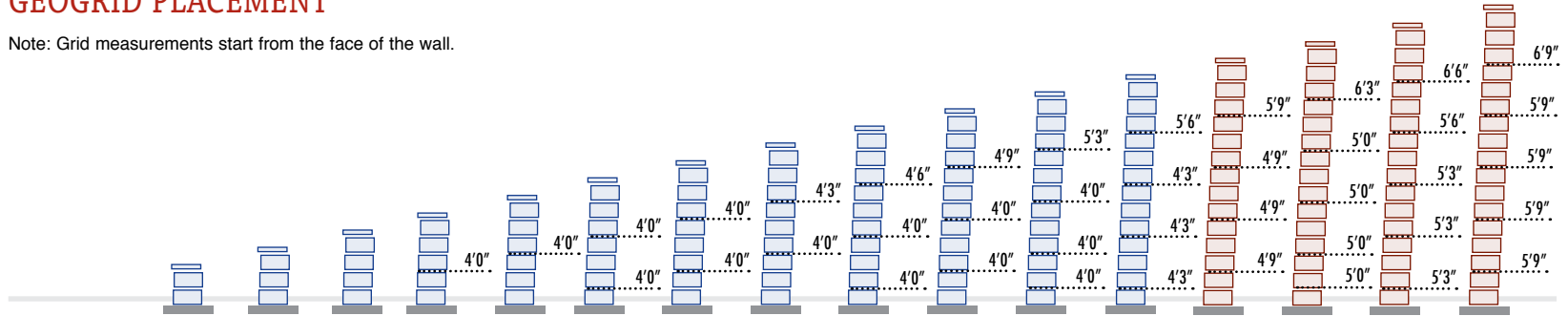

Geogrid Type	SRW Universal - or - SRW 3 Series Grid												SRW 3 Series Grid ONLY			
	0'6"	1'0"	1'6"	2'0"	2'6"	3'0"	3'6"	4'0"	4'6"	5'0"	5'6"	6'0"	6'6"	7'0"	7'6"	8'0"
Exposed Hgt wo/cap	0'6"	1'0"	1'6"	2'0"	2'6"	3'0"	3'6"	4'0"	4'6"	5'0"	5'6"	6'0"	6'6"	7'0"	7'6"	8'0"
Amount Buried	6"	6"	6"	6"	6"	6"	6"	6"	6"	6"	6"	6"	6"	6"	6"	6"
Total Hgt wo/cap	1.0'	1.5'	2'	2.5'	3'	3.5'	4'	4.5'	5'	5.5'	6'	6.5'	7'	7.5'	8'	8.5'
Grid Sq Yd per Ln Ft	0.000	0.000	0.000	0.444	0.444	0.889	0.889	0.889	1.389	1.417	1.917	2.028	2.222	2.917	3.083	3.306
Grid total depth	-	-	-	4.00	4.00	8.00	8.00	8.00	12.50	12.75	17.25	18.25	20.00	26.25	27.75	29.75
Sq Ft Block/Ln Ft	2.40	3.60	4.80	6.00	7.20	8.40	9.60	10.80	12.00	13.20	14.40	15.60	16.80	18.00	19.20	20.40
# Cap per Ln Ft	1.00	1.00	1.00	1.00	1.00	1.00	1.00	1.00	1.00	1.00	1.00	1.00	1.00	1.00	1.00	1.00

See "Material Estimating" for Adhesive estimate

CASE B

- "CASE B" Retaining Wall:**
- Flat Ground at Top of Wall
 - Flat Ground at Bottom of Wall
 - 100 psf Surcharge on Wall

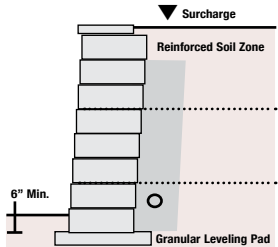

IF STAMPED ENGINEERING IS REQUIRED FOR THIS RETAINING WALL: THIS DESIGN MUST BE STAMPED HERE BY A LICENSED ENGINEER.

GEOGRID PLACEMENT

Note: Grid measurements start from the face of the wall.
• 100 psf Surcharge is light traffic i.e. car or pickup

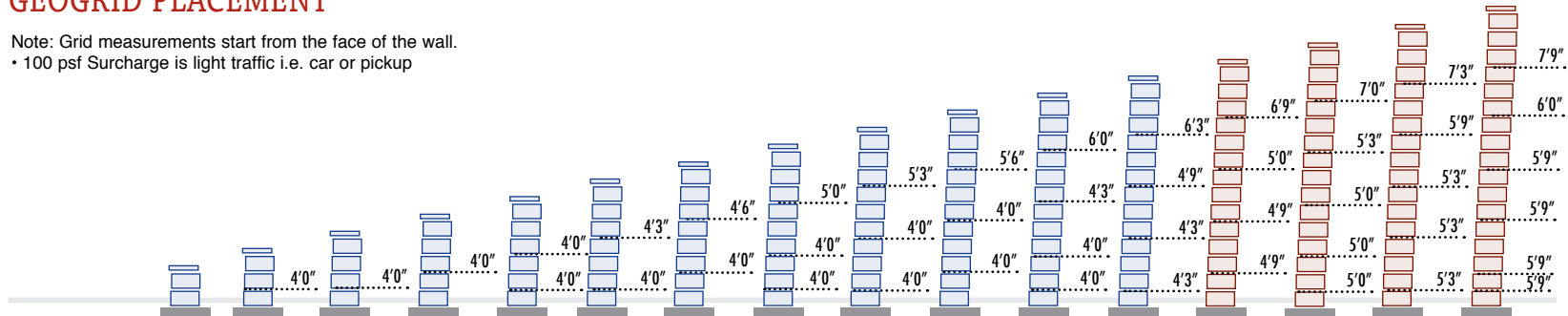

Geogrid Type	SRW Universal - or - SRW 3 Series Grid												SRW 3 Series Grid ONLY			
	0'6"	1'0"	1'6"	2'0"	2'6"	3'0"	3'6"	4'0"	4'6"	5'0"	5'6"	6'0"	6'6"	7'0"	7'6"	8'0"
Exposed Hgt wo/cap	0'6"	1'0"	1'6"	2'0"	2'6"	3'0"	3'6"	4'0"	4'6"	5'0"	5'6"	6'0"	6'6"	7'0"	7'6"	8'0"
Amount Buried	6"	6"	6"	6"	6"	6"	6"	6"	6"	6"	6"	6"	6"	6"	6"	6"
Total Hgt wo/cap	1.0'	1.5'	2'	2.5'	3'	3.5'	4'	4.5'	5'	5.5'	6'	6.5'	7'	7.5'	8'	8.5'
Grid Sq Yd per Ln Ft	0.000	0.444	0.444	0.444	0.889	0.917	0.944	1.444	1.472	1.500	2.028	2.167	2.361	3.028	3.194	4.083
Grid total depth	-	4.00	4.00	4.00	8.00	8.25	8.50	13.00	13.25	13.50	18.25	19.50	21.25	27.25	28.75	36.75
Sq Ft Block/Ln Ft	2.40	3.60	4.80	6.00	7.20	8.40	9.60	10.80	12.00	13.20	14.40	15.60	16.80	18.00	19.20	20.40
# Cap per Ln Ft	1.00	1.00	1.00	1.00	1.00	1.00	1.00	1.00	1.00	1.00	1.00	1.00	1.00	1.00	1.00	1.00

See "Material Estimating" for Adhesive estimate

Geogrid: SRW Universal 635 LTDS or SRW 3 Series 1093 LTDS • Block Dimensions: 6"(H) x 8", 10" OR 12" (W) x 10"(D) • Avg Cover: .4167 Sq.Ft.

If used without the stamped engineering, the final determination of the suitability of the contemplated use, and its manner of use, are the sole responsibility of the user, and the user expressly releases HTS, SRW, and retaining wall unit supplier of any and all liability that might arise as a result. These designs have been performed with National Concrete Masonry Association (NCMA) software and have been analyzed for the appropriate factors of safety. © 2009 Hardscape Technical Services • Maytrx® is a registered trademark of Maytrx Premier Stone System.

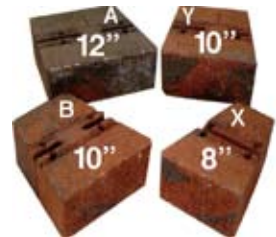

26 DEGREE SOIL

for walls up to 8'

Maytrx® Block • SRW Accessories

26 DEGREE SOIL for walls up to 8'

Maytrx® Block • SRW Accessories

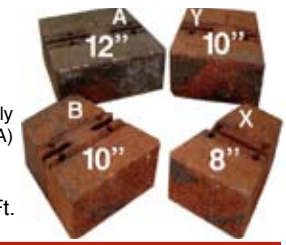

If used without the stamped engineering, the final determination of the suitability of the contemplated use, and its manner of use, are the sole responsibility of the user, and the user expressly releases HTS, SRW, and retaining wall unit supplier of any and all liability that might arise as a result. These designs have been performed with National Concrete Masonry Association (NCMA) software and have been analyzed for the appropriate factors of safety. © 2009 Hardscape Technical Services • Maytrx® is a registered trademark of Maytrx Premier Stone System.

Geogrid: SRW Universal 635 LTDS or SRW 3 Series 1093 LTDS • Block Dimensions: 6”(H) x 8”, 10” OR 12” (W) x 10”(D) • Avg Cover: .4167 Sq.Ft.

CASE C

- “CASE C” Retaining Wall:**
- Flat Ground at Top of Wall
 - Flat Ground at Bottom of Wall
 - 250 psf Surcharge on Wall

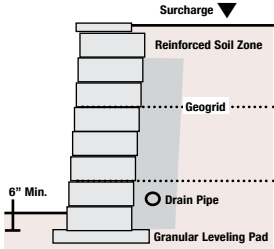

IF STAMPED ENGINEERING IS REQUIRED FOR THIS RETAINING WALL: THIS DESIGN MUST BE STAMPED HERE BY A LICENSED ENGINEER.

GEOGRID PLACEMENT

- Note: Grid measurements start from the face of the wall.
- Surcharge begins two feet behind wall facing.
 - 250 psf Surcharge is heavier traffic i.e. RV, large vehicle

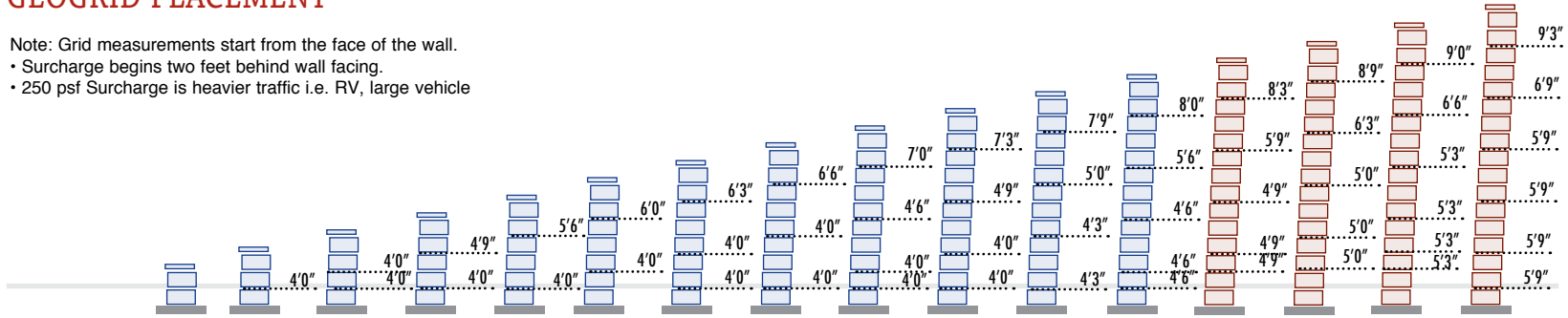

Geogrid Type	SRW Universal - or - SRW 3 Series Grid												SRW 3 Series Grid ONLY			
	0'6"	1'0"	1'6"	2'0"	2'6"	3'0"	3'6"	4'0"	4'6"	5'0"	5'6"	6'0"	6'6"	7'0"	7'6"	8'0"
Exposed Hgt wo/cap	0'6"	1'0"	1'6"	2'0"	2'6"	3'0"	3'6"	4'0"	4'6"	5'0"	5'6"	6'0"	6'6"	7'0"	7'6"	8'0"
Amount Buried	6"	6"	6"	6"	6"	6"	6"	6"	6"	6"	6"	6"	6"	6"	6"	6"
Total Hgt wo/cap	1.0'	1.5'	2'	2.5'	3'	3.5'	4'	4.5'	5'	5.5'	6'	6.5'	7'	7.5'	8'	8.5'
Grid Sq Yd per Ln Ft	0.000	0.444	0.889	0.972	1.056	1.111	1.583	1.611	2.167	2.222	2.361	3.000	3.139	3.333	4.056	4.333
Grid total depth	-	4.00	8.00	8.75	9.50	10.00	14.25	14.50	19.50	20.00	21.25	27.00	28.25	30.00	36.50	39.00
Sq Ft Block/Ln Ft	2.40	3.60	4.80	6.00	7.20	8.40	9.60	10.80	12.00	13.20	14.40	15.60	16.80	18.00	19.20	20.40
# Cap per Ln Ft	1.00	1.00	1.00	1.00	1.00	1.00	1.00	1.00	1.00	1.00	1.00	1.00	1.00	1.00	1.00	1.00

See "Material Estimating" for Adhesive estimate

CASE D

- “CASE D” Retaining Wall:**
- 4/1 Slope at Top of Wall
 - Flat Ground at Bottom of Wall
 - No Surcharge on Wall

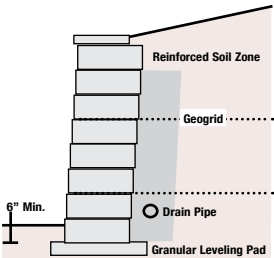

IF STAMPED ENGINEERING IS REQUIRED FOR THIS RETAINING WALL: THIS DESIGN MUST BE STAMPED HERE BY A LICENSED ENGINEER.

GEOGRID PLACEMENT

- Note: Grid measurements start from the face of the wall.

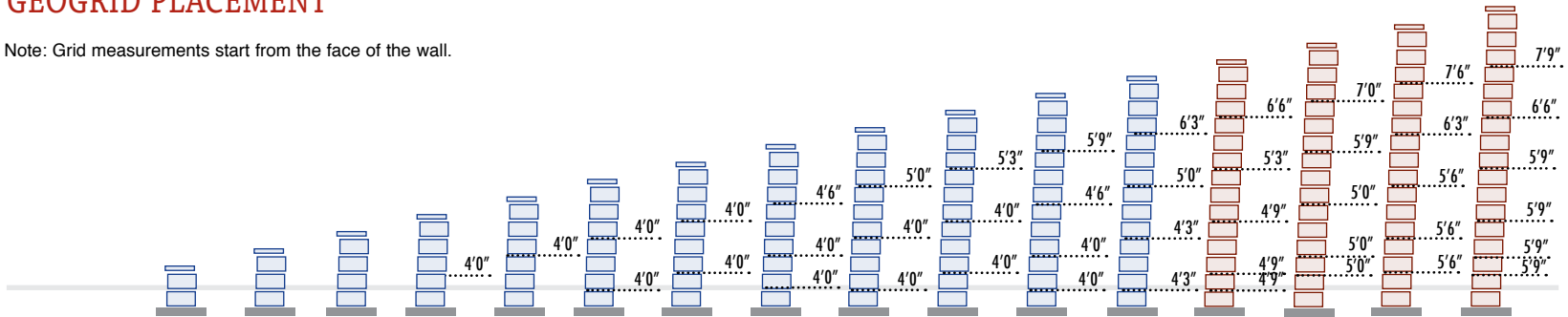

Geogrid Type	SRW Universal - or - SRW 3 Series Grid												SRW 3 Series Grid ONLY			
	0'6"	1'0"	1'6"	2'0"	2'6"	3'0"	3'6"	4'0"	4'6"	5'0"	5'6"	6'0"	6'6"	7'0"	7'6"	8'0"
Exposed Hgt wo/cap	0'6"	1'0"	1'6"	2'0"	2'6"	3'0"	3'6"	4'0"	4'6"	5'0"	5'6"	6'0"	6'6"	7'0"	7'6"	8'0"
Amount Buried	6"	6"	6"	6"	6"	6"	6"	6"	6"	6"	6"	6"	6"	6"	6"	6"
Total Hgt wo/cap	1.0'	1.5'	2'	2.5'	3'	3.5'	4'	4.5'	5'	5.5'	6'	6.5'	7'	7.5'	8'	8.5'
Grid Sq Yd per Ln Ft	0.000	0.000	0.000	0.444	0.444	0.889	0.889	1.389	1.444	1.472	2.028	2.194	2.889	3.083	3.361	4.139
Grid total depth	-	-	-	4.00	4.00	8.00	8.00	12.50	13.00	13.25	18.25	19.75	26.00	27.75	30.25	37.25
Sq Ft Block/Ln Ft	2.40	3.60	4.80	6.00	7.20	8.40	9.60	10.80	12.00	13.20	14.40	15.60	16.80	18.00	19.20	20.40
# Cap per Ln Ft	1.00	1.00	1.00	1.00	1.00	1.00	1.00	1.00	1.00	1.00	1.00	1.00	1.00	1.00	1.00	1.00

See "Material Estimating" for Adhesive estimate

CASE E

- "CASE E" Retaining Wall:**
- 3/1 Slope at Top of Wall
 - Flat Ground at Bottom of Wall
 - No Surcharge on Wall

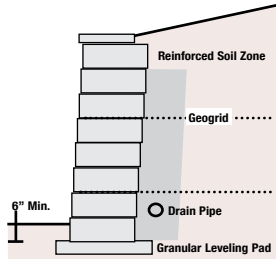

IF STAMPED ENGINEERING IS REQUIRED FOR THIS RETAINING WALL: THIS DESIGN MUST BE STAMPED HERE BY A LICENSED ENGINEER.

GEOGRID PLACEMENT

Note: Grid measurements start from the face of the wall.

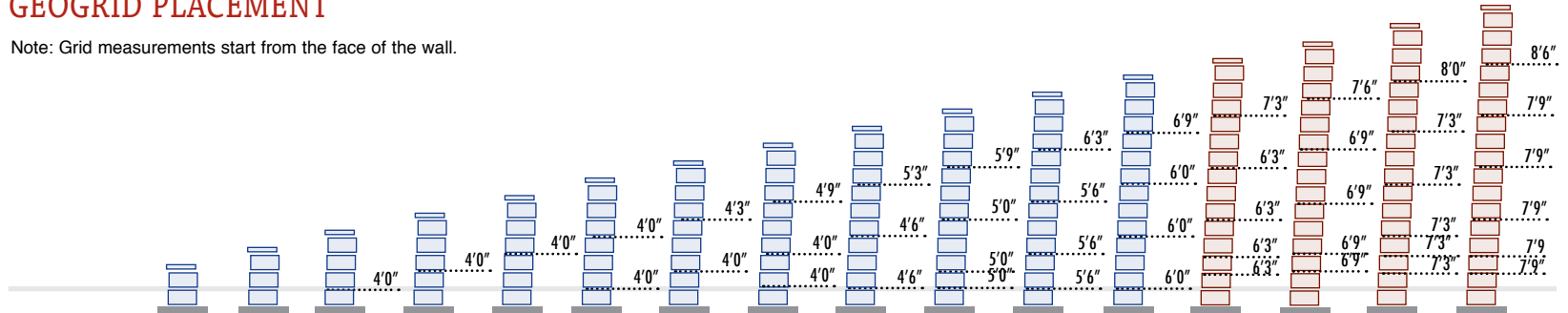

Geogrid Type	SRW Universal - or - SRW 3 Series Grid												SRW 3 Series Grid ONLY			
	0'6"	1'0"	1'6"	2'0"	2'6"	3'0"	3'6"	4'0"	4'6"	5'0"	5'6"	6'0"	6'6"	7'0"	7'6"	8'0"
Exposed Hgt wo/cap	0'6"	1'0"	1'6"	2'0"	2'6"	3'0"	3'6"	4'0"	4'6"	5'0"	5'6"	6'0"	6'6"	7'0"	7'6"	8'0"
Amount Buried	6"	6"	6"	6"	6"	6"	6"	6"	6"	6"	6"	6"	6"	6"	6"	6"
Total Hgt wo/cap	1.0'	1.5'	2'	2.5'	3'	3.5'	4'	4.5'	5'	5.5'	6'	6.5'	7'	7.5'	8'	8.5'
Grid Sq Yd per Ln Ft	0.000	0.000	0.444	0.444	0.444	0.889	0.917	1.417	1.583	1.750	2.528	2.750	3.583	3.833	4.917	5.250
Grid total depth	-	-	4.00	4.00	4.00	8.00	8.25	12.75	14.25	15.75	22.75	24.75	32.25	34.50	44.25	47.25
Sq Ft Block/Ln Ft	2.40	3.60	4.80	6.00	7.20	8.40	9.60	10.80	12.00	13.20	14.40	15.60	16.80	18.00	19.20	20.40
# Cap per Ln Ft	1.00	1.00	1.00	1.00	1.00	1.00	1.00	1.00	1.00	1.00	1.00	1.00	1.00	1.00	1.00	1.00

See "Material Estimating" for Adhesive estimate

CASE F

- "CASE F" Retaining Wall:**
- Flat Ground at Top of Wall
 - 5/1 Slope at Bottom of Wall
 - No Surcharge on Wall

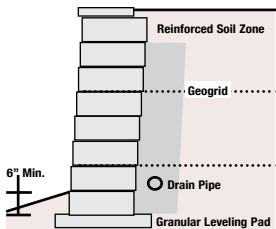

IF STAMPED ENGINEERING IS REQUIRED FOR THIS RETAINING WALL: THIS DESIGN MUST BE STAMPED HERE BY A LICENSED ENGINEER.

GEOGRID PLACEMENT

Note: Grid measurements start from the face of the wall.

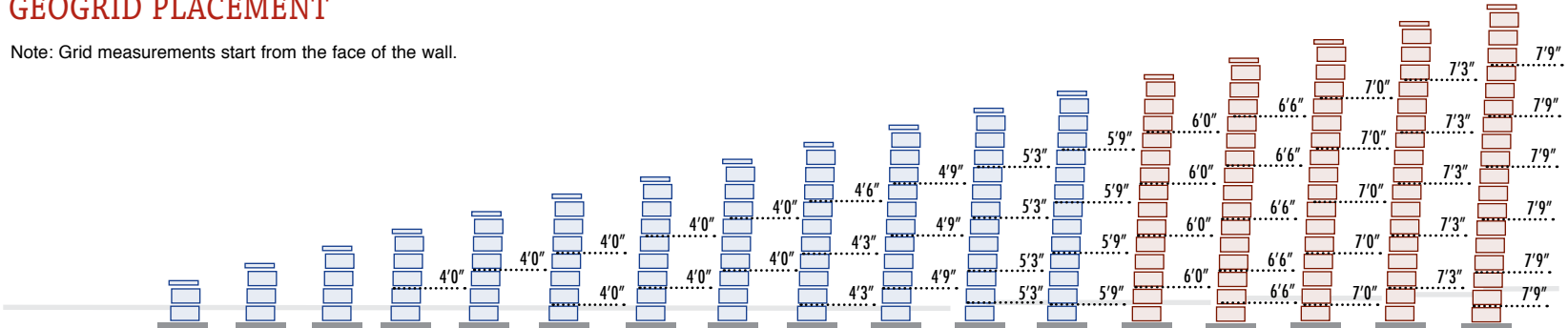

Geogrid Type	SRW Universal - or - SRW 3 Series Grid												SRW 3 Series Grid ONLY				
	0'6"	1'0"	1'6"	2'0"	2'6"	3'0"	3'6"	4'0"	4'6"	5'0"	5'5"	5'10"	6'4"	6'9"	7'3"	7'8"	8'0"
Exposed Hgt wo/cap	0'6"	1'0"	1'6"	2'0"	2'6"	3'0"	3'6"	4'0"	4'6"	5'0"	5'5"	5'10"	6'4"	6'9"	7'3"	7'8"	8'0"
Amount Buried	6"	6"	6"	6"	6"	6"	6"	6"	6"	6"	7"	8"	8"	9"	9"	10"	10"
Total Hgt wo/cap	1.0'	1.5'	2'	2.5'	3'	3.5'	4'	4.5'	5'	5.5'	6'	6.5'	7'	7.5'	8'	8.5'	9'
Grid Sq Yd per Ln Ft	0.000	0.000	0.000	0.444	0.444	0.889	0.889	0.889	1.444	1.583	2.333	2.556	2.667	3.611	3.889	4.028	5.167
Grid total depth	-	-	-	4.00	4.00	8.00	8.00	8.00	13.00	14.25	21.00	23.00	24.00	32.50	35.00	36.25	46.50
Sq Ft Block/Ln Ft	2.40	3.60	4.80	6.00	7.20	8.40	9.60	10.80	12.00	13.20	14.40	15.60	16.80	18.00	19.20	20.40	21.60
# Cap per Ln Ft	1.00	1.00	1.00	1.00	1.00	1.00	1.00	1.00	1.00	1.00	1.00	1.00	1.00	1.00	1.00	1.00	1.00

See "Material Estimating" for Adhesive estimate

Geogrid: SRW Universal 635 LTDS or SRW 3 Series 1093 LTDS • Block Dimensions: 6"(H) x 8", 10" OR 12" (W) x 10"(D) • Avg Cover: .4167 Sq.Ft.

If used without the stamped engineering, the final determination of the suitability of the contemplated use, and its manner of use, are the sole responsibility of the user, and the user expressly releases HTS, SRW, and retaining wall unit supplier of any and all liability that might arise as a result. These designs have been performed with National Concrete Masonry Association (NCMA) software and have been analyzed for the appropriate factors of safety. © 2009 Hardscape Technical Services • Maytrx® is a registered trademark of Maytrx Premier Stone System.



26 DEGREE SOIL for walls up to 8'

Maytrx® Block • SRW Accessories

26 DEGREE SOIL for walls up to 8'

Maytrx® Block • SRW Accessories

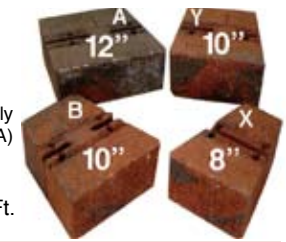

If used without the stamped engineering, the final determination of the suitability of the contemplated use, and its manner of use, are the sole responsibility of the user, and the user expressly releases HTS, SRW, and retaining wall unit supplier of any and all liability that might arise as a result. These designs have been performed with National Concrete Masonry Association (NCMA) software and have been analyzed for the appropriate factors of safety. © 2009 Hardscape Technical Services • Maytrx® is a registered trademark of Maytrx Premier Stone System.

Geogrid: SRW Universal 635 LTDS or SRW 3 Series 1093 LTDS • Block Dimensions: 6”(H) x 8”, 10” OR 12” (W) x 10”(D) • Avg Cover: .4167 Sq.Ft.

CASE G

- “CASE G” Retaining Wall:**
- Flat Ground at Top of Wall
 - 5/1 Slope at Bottom of Wall
 - 100 psf Surcharge on Wall

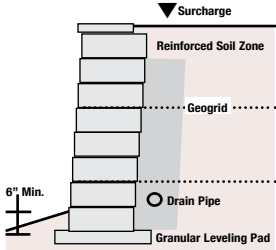

IF STAMPED ENGINEERING IS REQUIRED FOR THIS RETAINING WALL: THIS DESIGN MUST BE STAMPED HERE BY A LICENSED ENGINEER.

GEOGRID PLACEMENT

Note: Grid measurements start from the face of the wall.
• 100 psf Surcharge is light traffic i.e. car or pickup

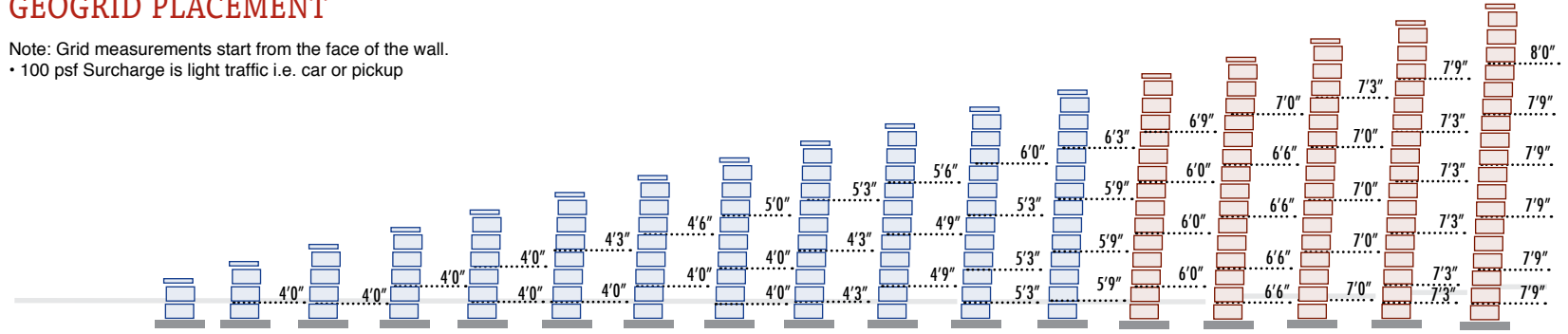

Geogrid Type	SRW Universal - or - SRW 3 Series Grid												SRW 3 Series Grid ONLY				
	0'6"	1'0"	1'6"	2'0"	2'6"	3'0"	3'6"	4'0"	4'6"	5'0"	5'5"	5'10"	6'4"	6'9"	7'3"	7'8"	8'0"
Exposed Hgt wo/cap	0'6"	1'0"	1'6"	2'0"	2'6"	3'0"	3'6"	4'0"	4'6"	5'0"	5'5"	5'10"	6'4"	6'9"	7'3"	7'8"	8'0"
Amount Buried	6"	6"	6"	6"	6"	6"	6"	6"	6"	6"	7"	8"	8"	9"	9"	10"	10"
Total Hgt wo/cap	1.0'	1.5'	2'	2.5'	3'	3.5'	4'	4.5'	5'	5.5'	6'	6.5'	7'	7.5'	8'	8.5'	9'
Grid Sq Yd per Ln Ft	0.000	0.444	0.444	0.444	0.889	0.917	0.944	1.444	1.528	1.667	2.417	2.611	2.750	3.667	3.917	4.889	5.194
Grid total depth	-	4.00	4.00	4.00	8.00	8.25	8.50	13.00	13.75	15.00	21.75	23.50	24.75	33.00	35.25	44.00	46.75
Sq Ft Block/Ln Ft	2.40	3.60	4.80	6.00	7.20	8.40	9.60	10.80	12.00	13.20	14.40	15.60	16.80	18.00	19.20	20.40	21.60
# Cap per Ln Ft	1.00	1.00	1.00	1.00	1.00	1.00	1.00	1.00	1.00	1.00	1.00	1.00	1.00	1.00	1.00	1.00	1.00

See “Material Estimating” for Adhesive estimate

CASE H

- “CASE H” Retaining Wall:**
- Flat Ground at Top of Wall
 - 5/1 Slope at Bottom of Wall
 - 250 psf Surcharge on Wall

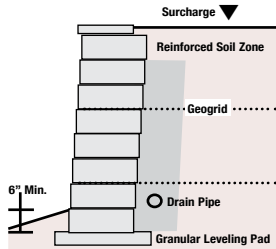

IF STAMPED ENGINEERING IS REQUIRED FOR THIS RETAINING WALL: THIS DESIGN MUST BE STAMPED HERE BY A LICENSED ENGINEER.

GEOGRID PLACEMENT

Note: Grid measurements start from the face of the wall.
• Surcharge begins two feet behind wall facing.
• 250 psf Surcharge is heavier traffic i.e. RV, large vehicle

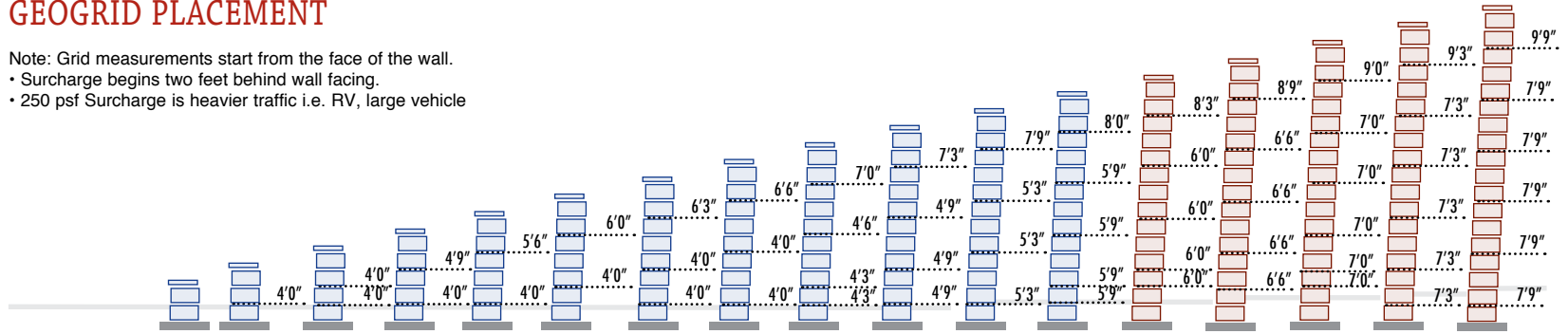

Geogrid Type	SRW Universal - or - SRW 3 Series Grid												SRW 3 Series Grid ONLY				
	0'6"	1'0"	1'6"	2'0"	2'6"	3'0"	3'6"	4'0"	4'6"	5'0"	5'5"	5'10"	6'4"	6'9"	7'3"	7'8"	8'0"
Exposed Hgt wo/cap	0'6"	1'0"	1'6"	2'0"	2'6"	3'0"	3'6"	4'0"	4'6"	5'0"	5'5"	5'10"	6'4"	6'9"	7'3"	7'8"	8'0"
Amount Buried	6"	6"	6"	6"	6"	6"	6"	6"	6"	6"	7"	8"	8"	9"	9"	10"	10"
Total Hgt wo/cap	1.0'	1.5'	2'	2.5'	3'	3.5'	4'	4.5'	5'	5.5'	6'	6.5'	7'	7.5'	8'	8.5'	9'
Grid Sq Yd per Ln Ft	0.000	0.444	0.889	0.972	1.056	1.111	1.583	1.611	2.222	2.389	2.611	3.444	3.583	3.861	4.889	5.056	5.389
Grid total depth	-	4.00	8.00	8.75	9.50	10.00	14.25	14.50	20.00	21.50	23.50	31.00	32.25	34.75	44.00	45.50	48.50
Sq Ft Block/Ln Ft	2.40	3.60	4.80	6.00	7.20	8.40	9.60	10.80	12.00	13.20	14.40	15.60	16.80	18.00	19.20	20.40	21.60
# Cap per Ln Ft	1.00	1.00	1.00	1.00	1.00	1.00	1.00	1.00	1.00	1.00	1.00	1.00	1.00	1.00	1.00	1.00	1.00

See “Material Estimating” for Adhesive estimate

CASE I

- "CASE I" Retaining Wall:**
- Flat Ground at Top of Wall
 - 4/1 Slope at Bottom of Wall
 - No Surcharge on Wall

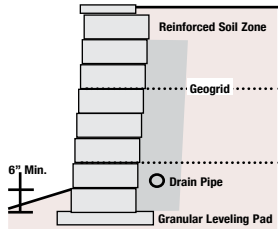

IF STAMPED ENGINEERING IS REQUIRED FOR THIS RETAINING WALL: THIS DESIGN MUST BE STAMPED HERE BY A LICENSED ENGINEER.

GEOGRID PLACEMENT

Note: Grid measurements start from the face of the wall.

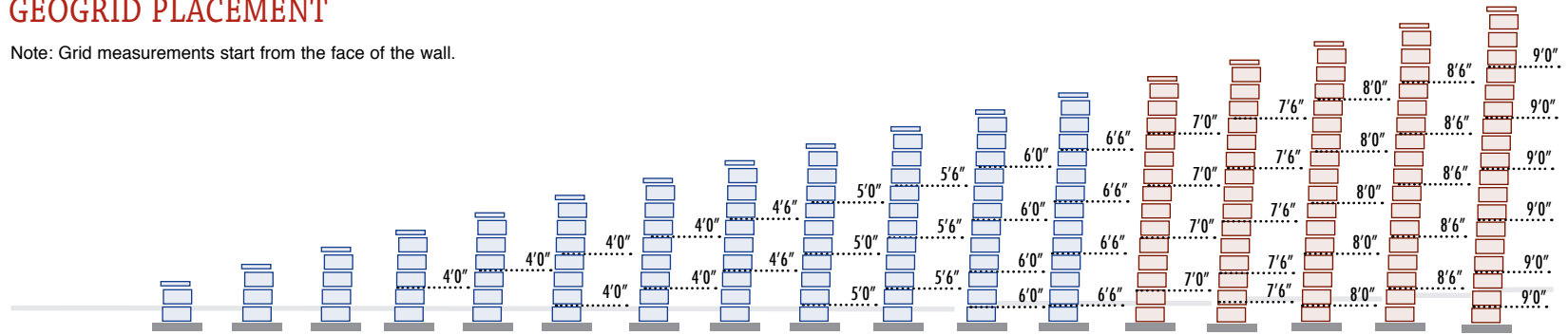

Geogrid Type	SRW Universal - or - SRW 3 Series Grid												SRW 3 Series Grid ONLY				
Exposed Hgt wo/cap	0'6"	1'0"	1'6"	2'0"	2'6"	3'0"	3'6"	4'0"	4'6"	5'0"	5'5"	5'10"	6'4"	6'9"	7'3"	7'8"	8'0"
Amount Buried	6"	6"	6"	6"	6"	6"	6"	6"	6"	6"	7"	8"	8"	9"	9"	10"	1'0"
Total Hgt wo/cap	1.0'	1.5'	2'	2.5'	3'	3.5'	4'	4.5'	5'	5.5'	6'	6.5'	7'	7.5'	8'	8.5'	9'
Grid Sq Yd per Ln Ft	0.000	0.000	0.000	0.444	0.444	0.889	0.889	1.000	1.667	1.833	2.667	2.889	3.111	4.167	4.444	4.722	6.000
Grid total depth	-	-	-	4.00	4.00	8.00	8.00	9.00	15.00	16.50	24.00	26.00	28.00	37.50	40.00	42.50	54.00
Sq Ft Block/Ln Ft	2.40	3.60	4.80	6.00	7.20	8.40	9.60	10.80	12.00	13.20	14.40	15.60	16.80	18.00	19.20	20.40	21.60
# Cap per Ln Ft	1.00	1.00	1.00	1.00	1.00	1.00	1.00	1.00	1.00	1.00	1.00	1.00	1.00	1.00	1.00	1.00	1.00

See "Material Estimating" for Adhesive estimate

CASE J

- "CASE J" Retaining Wall:**
- Flat Ground at Top of Wall
 - 4/1 Slope at Bottom of Wall
 - 100 psf Surcharge on Wall

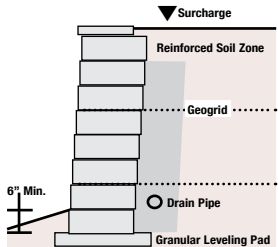

IF STAMPED ENGINEERING IS REQUIRED FOR THIS RETAINING WALL: THIS DESIGN MUST BE STAMPED HERE BY A LICENSED ENGINEER.

GEOGRID PLACEMENT

Note: Grid measurements start from the face of the wall.
• 100 psf Surcharge is light traffic i.e. car or pickup

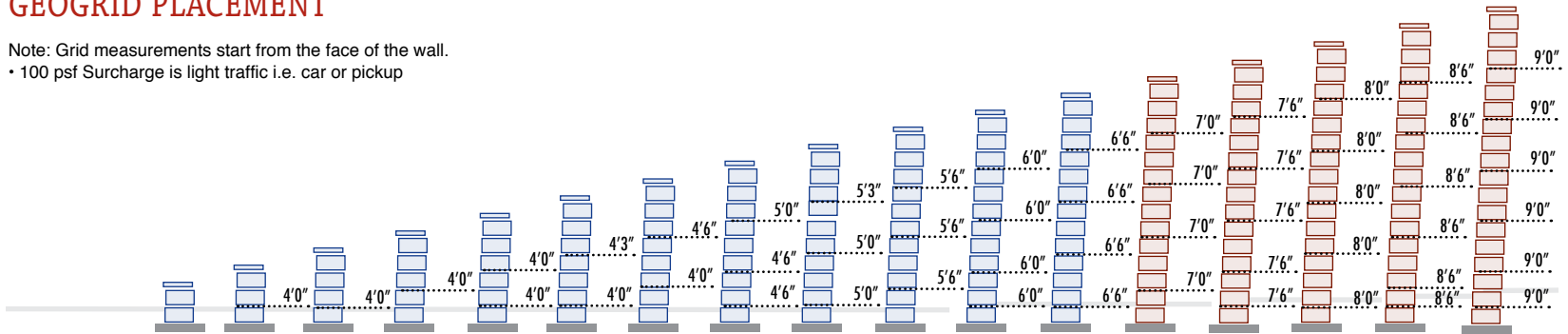

Geogrid Type	SRW Universal - or - SRW 3 Series Grid												SRW 3 Series Grid ONLY				
Exposed Hgt wo/cap	0'6"	1'0"	1'6"	2'0"	2'6"	3'0"	3'6"	4'0"	4'6"	5'0"	5'5"	5'10"	6'4"	6'9"	7'3"	7'8"	8'0"
Amount Buried	6"	6"	6"	6"	6"	6"	6"	6"	6"	6"	7"	8"	8"	9"	9"	10"	1'0"
Total Hgt wo/cap	1.0'	1.5'	2'	2.5'	3'	3.5'	4'	4.5'	5'	5.5'	6'	6.5'	7'	7.5'	8'	8.5'	9'
Grid Sq Yd per Ln Ft	0.000	0.444	0.444	0.444	0.889	0.917	0.944	1.556	1.694	1.833	2.667	2.889	3.111	4.167	4.444	5.667	6.000
Grid total depth	-	4.00	4.00	4.00	8.00	8.25	8.50	14.00	15.25	16.50	24.00	26.00	28.00	37.50	40.00	51.00	54.00
Sq Ft Block/Ln Ft	2.40	3.60	4.80	6.00	7.20	8.40	9.60	10.80	12.00	13.20	14.40	15.60	16.80	18.00	19.20	20.40	21.60
# Cap per Ln Ft	1.00	1.00	1.00	1.00	1.00	1.00	1.00	1.00	1.00	1.00	1.00	1.00	1.00	1.00	1.00	1.00	1.00

See "Material Estimating" for Adhesive estimate

Geogrid: SRW Universal 635 LTDS or SRW 3 Series 1093 LTDS • Block Dimensions: 6"(H) x 8", 10" OR 12" (W) x 10"(D) • Avg Cover: .4167 Sq.Ft.

If used without the stamped engineering, the final determination of the suitability of the contemplated use, and its manner of use, are the sole responsibility of the user, and the user expressly releases HTS, SRW, and retaining wall unit supplier of any and all liability that might arise as a result. These designs have been performed with National Concrete Masonry Association (NCMA) software and have been analyzed for the appropriate factors of safety. © 2009 Hardscape Technical Services • Maytrx® is a registered trademark of Maytrx Premier Stone System.



26 DEGREE SOIL

for walls up to 8'

Maytrx® Block • SRW Accessories

26 DEGREE SOIL for walls up to 8'

Maytrx® Block • SRW Accessories

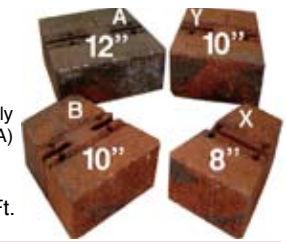

If used without the stamped engineering, the final determination of the suitability of the contemplated use, and its manner of use, are the sole responsibility of the user, and the user expressly releases HTS, SRW, and retaining wall unit supplier of any and all liability that might arise as a result. These designs have been performed with National Concrete Masonry Association (NCMA) software and have been analyzed for the appropriate factors of safety. © 2009 Hardscape Technical Services • Maytrx® is a registered trademark of Maytrx Premier Stone System.

Geogrid: SRW Universal 635 LTDS or SRW 3 Series 1093 LTDS • Block Dimensions: 6"(H) x 8", 10" OR 12" (W) x 10"(D) • Avg Cover: .4167 Sq.Ft.

CASE K

- "CASE K" Retaining Wall:**
- Flat Ground at Top of Wall
 - 4/1 Slope at Bottom of Wall
 - 250 psf Surcharge on Wall

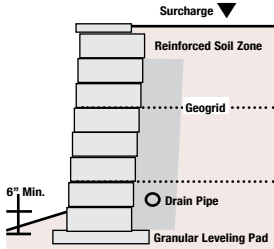

IF STAMPED ENGINEERING IS REQUIRED FOR THIS RETAINING WALL: THIS DESIGN MUST BE STAMPED HERE BY A LICENSED ENGINEER.

GEOGRID PLACEMENT

- Note: Grid measurements start from the face of the wall.
- Surcharge begins two feet behind wall facing.
 - 250 psf Surcharge is heavier traffic i.e. RV, large vehicle

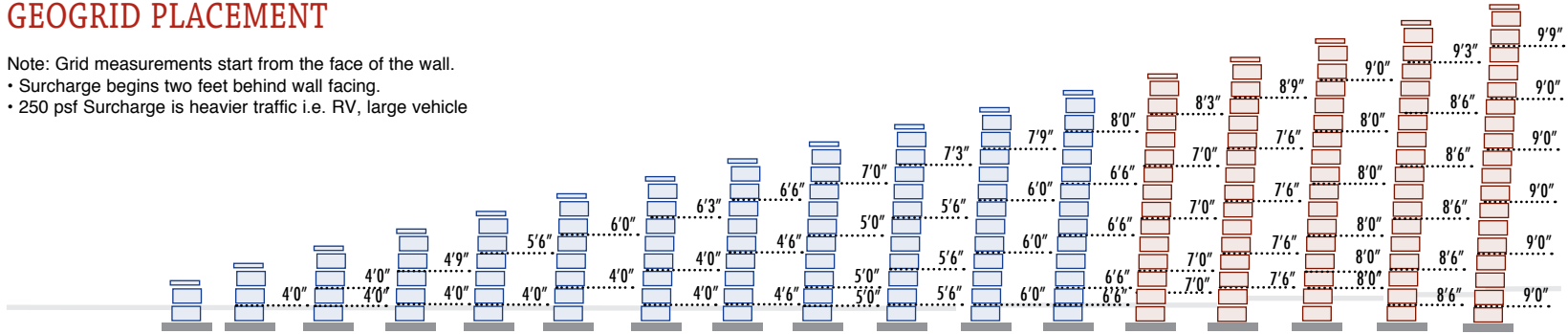

Geogrid Type	SRW Universal - or - SRW 3 Series Grid												SRW 3 Series Grid ONLY				
	0'6"	1'0"	1'6"	2'0"	2'6"	3'0"	3'6"	4'0"	4'6"	5'0"	5'5"	5'10"	6'4"	6'9"	7'3"	7'8"	8'0"
Exposed Hgt wo/cap	0'6"	1'0"	1'6"	2'0"	2'6"	3'0"	3'6"	4'0"	4'6"	5'0"	5'5"	5'10"	6'4"	6'9"	7'3"	7'8"	8'0"
Amount Buried	6"	6"	6"	6"	6"	6"	6"	6"	6"	6"	7"	8"	8"	9"	9"	10"	1'0"
Total Hgt wo/cap	1.0'	1.5'	2'	2.5'	3'	3.5'	4'	4.5'	5'	5.5'	6'	6.5'	7'	7.5'	8'	8.5'	9'
Grid Sq Yd per Ln Ft	0.000	0.444	0.889	0.972	1.056	1.111	1.583	1.772	2.444	2.639	2.861	3.778	4.028	4.306	5.444	5.750	6.083
Grid total depth	-	4.00	8.00	8.75	9.50	10.00	14.25	15.50	22.00	23.75	25.75	34.00	36.25	38.75	49.00	51.75	54.75
Sq Ft Block/Ln Ft	2.40	3.60	4.80	6.00	7.20	8.40	9.60	10.80	12.00	13.20	14.40	15.60	16.80	18.00	19.20	20.40	21.60
# Cap per Ln Ft	1.00	1.00	1.00	1.00	1.00	1.00	1.00	1.00	1.00	1.00	1.00	1.00	1.00	1.00	1.00	1.00	1.00

See "Material Estimating" for Adhesive estimate

CASE L

- "CASE L" Retaining Wall:**
- Flat Ground at Top of Wall
 - 3/1 Slope at Bottom of Wall
 - No Surcharge on Wall

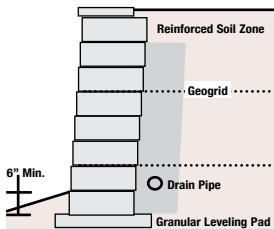

IF STAMPED ENGINEERING IS REQUIRED FOR THIS RETAINING WALL: THIS DESIGN MUST BE STAMPED HERE BY A LICENSED ENGINEER.

GEOGRID PLACEMENT

Note: Grid measurements start from the face of the wall.

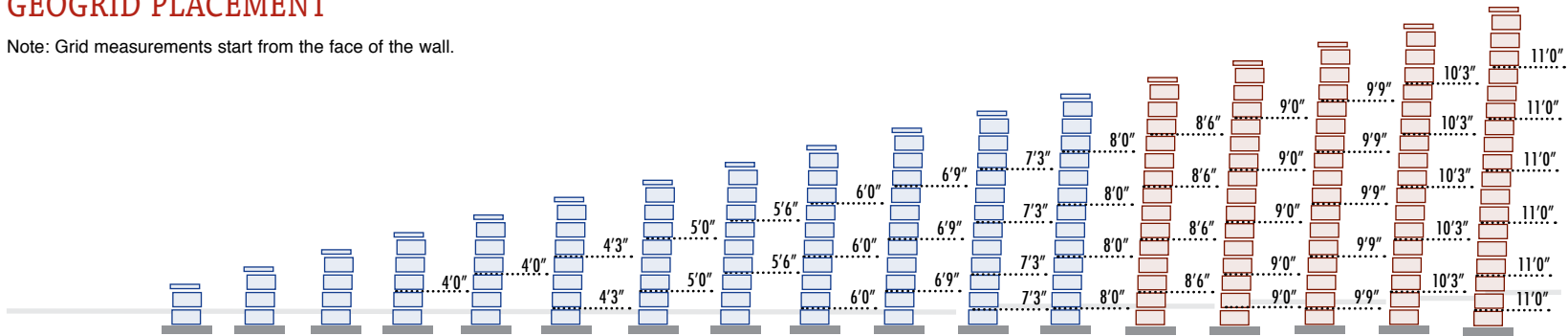

Geogrid Type	SRW Universal - or - SRW 3 Series Grid												SRW 3 Series Grid ONLY				
	0'6"	1'0"	1'6"	2'0"	2'6"	3'0"	3'6"	4'0"	4'6"	5'0"	5'5"	5'10"	6'4"	6'9"	7'3"	7'8"	8'0"
Exposed Hgt wo/cap	0'6"	1'0"	1'6"	2'0"	2'6"	3'0"	3'6"	4'0"	4'6"	5'0"	5'5"	5'10"	6'4"	6'9"	7'3"	7'8"	8'0"
Amount Buried	6"	6"	6"	6"	6"	6"	6"	6"	6"	6"	7"	8"	8"	9"	9"	10"	1'0"
Total Hgt wo/cap	1.0'	1.5'	2'	2.5'	3'	3.5'	4'	4.5'	5'	5.5'	6'	6.5'	7'	7.5'	8'	8.5'	9'
Grid Sq Yd per Ln Ft	0.000	0.000	0.000	0.444	0.444	0.944	1.111	1.222	2.000	2.250	3.222	3.556	3.778	5.000	5.417	5.694	7.333
Grid total depth	-	-	-	4.00	4.00	8.50	10.00	11.00	18.00	20.25	29.00	32.00	34.00	45.00	48.75	51.25	66.00
Sq Ft Block/Ln Ft	2.40	3.60	4.80	6.00	7.20	8.40	9.60	10.80	12.00	13.20	14.40	15.60	16.80	18.00	19.20	20.40	21.60
# Cap per Ln Ft	1.00	1.00	1.00	1.00	1.00	1.00	1.00	1.00	1.00	1.00	1.00	1.00	1.00	1.00	1.00	1.00	1.00

See "Material Estimating" for Adhesive estimate

CASE M

- "CASE M" Retaining Wall:**
- Flat Ground at Top of Wall
 - 3/1 Slope at Bottom of Wall
 - 100 psf Surcharge on Wall

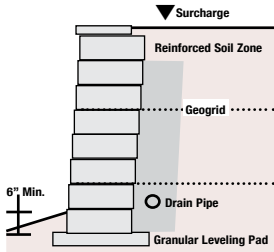

IF STAMPED ENGINEERING IS REQUIRED FOR THIS RETAINING WALL: THIS DESIGN MUST BE STAMPED HERE BY A LICENSED ENGINEER.

GEOGRID PLACEMENT

- Note: Grid measurements start from the face of the wall.
- 100 psf Surcharge is light traffic i.e. car or pickup

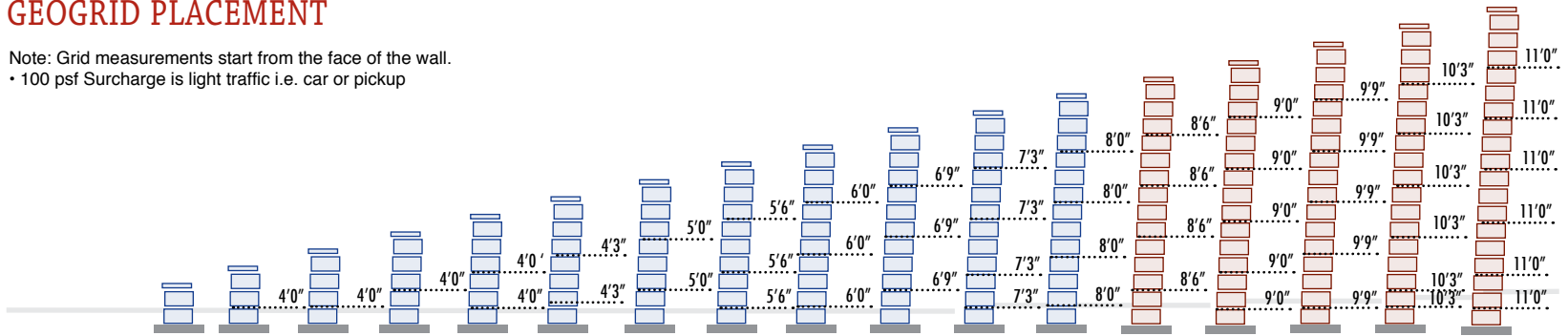

Geogrid Type	SRW Universal - or - SRW 3 Series Grid												SRW 3 Series Grid ONLY				
	0'6"	1'0"	1'6"	2'0"	2'6"	3'0"	3'6"	4'0"	4'6"	5'0"	5'5"	5'10"	6'4"	6'9"	7'3"	7'8"	8'0"
Exposed Hgt wo/cap	0'6"	1'0"	1'6"	2'0"	2'6"	3'0"	3'6"	4'0"	4'6"	5'0"	5'5"	5'10"	6'4"	6'9"	7'3"	7'8"	8'0"
Amount Buried	6"	6"	6"	6"	6"	6"	6"	6"	6"	6"	7"	8"	8"	9"	9"	10"	1'0"
Total Hgt wo/cap	1.0'	1.5'	2'	2.5'	3'	3.5'	4'	4.5'	5'	5.5'	6'	6.5'	7'	7.5'	8'	8.5'	9'
Grid Sq Yd per Ln Ft	0.000	0.444	0.444	0.444	0.889	0.944	1.111	1.833	2.000	2.250	3.222	3.556	3.778	5.000	5.417	6.833	7.333
Grid total depth	-	4.00	4.00	4.00	8.00	8.50	10.00	16.50	18.00	20.25	29.00	32.00	34.00	45.00	48.75	61.50	66.00
Sq Ft Block/Ln Ft	2.40	3.60	4.80	6.00	7.20	8.40	9.60	10.80	12.00	13.20	14.40	15.60	16.80	18.00	19.20	20.40	21.60
# Cap per Ln Ft	1.00	1.00	1.00	1.00	1.00	1.00	1.00	1.00	1.00	1.00	1.00	1.00	1.00	1.00	1.00	1.00	1.00

See "Material Estimating" for Adhesive estimate

CASE N

- "CASE N" Retaining Wall:**
- Flat Ground at Top of Wall
 - 3/1 Slope at Bottom of Wall
 - 250 psf Surcharge on Wall

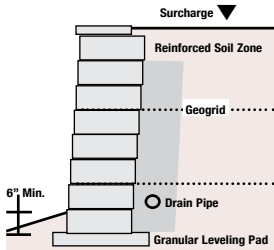

IF STAMPED ENGINEERING IS REQUIRED FOR THIS RETAINING WALL: THIS DESIGN MUST BE STAMPED HERE BY A LICENSED ENGINEER.

GEOGRID PLACEMENT

- Note: Grid measurements start from the face of the wall.
- Surcharge begins two feet behind wall facing.
 - 250 psf Surcharge is heavier traffic i.e. RV, large vehicle

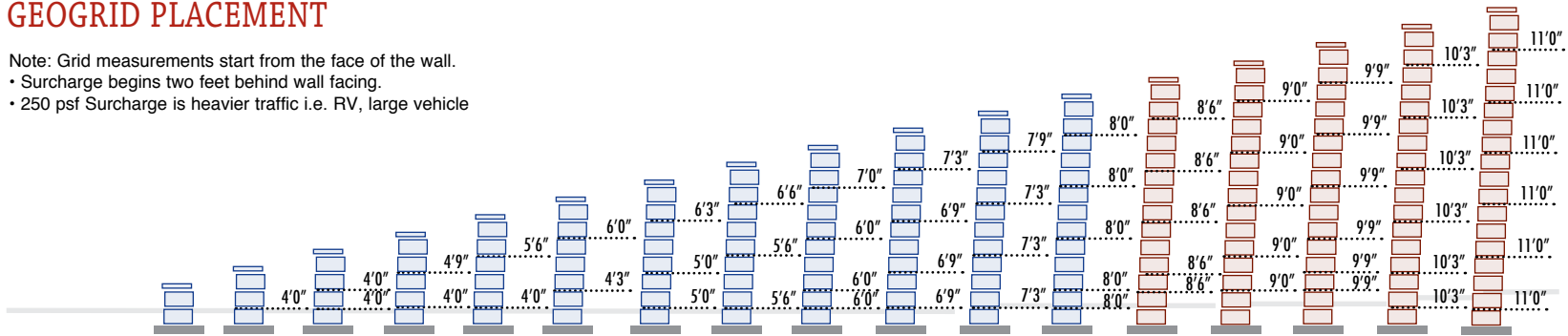

Geogrid Type	SRW Universal - or - SRW 3 Series Grid												SRW 3 Series Grid ONLY				
	0'6"	1'0"	1'6"	2'0"	2'6"	3'0"	3'6"	4'0"	4'6"	5'0"	5'5"	5'10"	6'4"	6'9"	7'3"	7'8"	8'0"
Exposed Hgt wo/cap	0'6"	1'0"	1'6"	2'0"	2'6"	3'0"	3'6"	4'0"	4'6"	5'0"	5'5"	5'10"	6'4"	6'9"	7'3"	7'8"	8'0"
Amount Buried	6"	6"	6"	6"	6"	6"	6"	6"	6"	6"	7"	8"	8"	9"	9"	10"	1'0"
Total Hgt wo/cap	1.0'	1.5'	2'	2.5'	3'	3.5'	4'	4.5'	5'	5.5'	6'	6.5'	7'	7.5'	8'	8.5'	9'
Grid Sq Yd per Ln Ft	0.000	0.444	0.889	0.972	1.056	1.139	1.806	1.944	2.778	3.056	3.278	4.444	4.722	5.000	6.500	6.833	7.333
Grid total depth	-	4.00	8.00	8.75	9.50	10.25	16.25	17.50	25.00	27.50	29.50	40.00	42.50	45.00	58.50	61.50	66.00
Sq Ft Block/Ln Ft	2.40	3.60	4.80	6.00	7.20	8.40	9.60	10.80	12.00	13.20	14.40	15.60	16.80	18.00	19.20	20.40	21.60
# Cap per Ln Ft	1.00	1.00	1.00	1.00	1.00	1.00	1.00	1.00	1.00	1.00	1.00	1.00	1.00	1.00	1.00	1.00	1.00

See "Material Estimating" for Adhesive estimate

Geogrid: SRW Universal 635 LTDS or SRW 3 Series 1093 LTDS • Block Dimensions: 6"(H) x 8", 10" OR 12" (W) x 10"(D) • Avg Cover: .4167 Sq.Ft.

If used without the stamped engineering, the final determination of the suitability of the contemplated use, and its manner of use, are the sole responsibility of the user, and the user expressly releases HTS, SRW, and retaining wall unit supplier of any and all liability that might arise as a result. These designs have been performed with National Concrete Masonry Association (NCMA) software and have been analyzed for the appropriate factors of safety. © 2009 Hardscape Technical Services • Maytrx® is a registered trademark of Maytrx Premier Stone System.

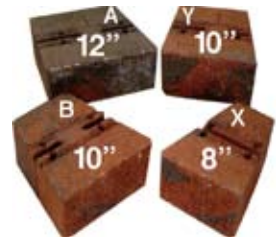

26 DEGREE SOIL

for walls up to 8'

Maytrx® Block • SRW Accessories

28 DEGREE SOIL for walls up to 8'

Maytrx® Block • SRW Accessories

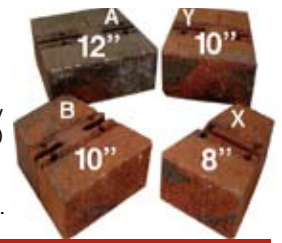

If used without the stamped engineering, the final determination of the suitability of the contemplated use, and its manner of use, are the sole responsibility of the user, and the user expressly releases HTS, SRW, and retaining wall unit supplier of any and all liability that might arise as a result. These designs have been performed with National Concrete Masonry Association (NCMA) software and have been analyzed for the appropriate factors of safety. © 2009 Hardscape Technical Services • Maytrx® is a registered trademark of Maytrx Premier Stone System.

Geogrid: SRW Universal 635 LTDS or SRW 3 Series 1093 LTDS • Block Dimensions: 6”(H) x 8”, 10” OR 12” (W) x 10”(D) • Avg Cover: .4167 Sq.Ft.

CASE A

- “CASE A” Retaining Wall:**
- Flat Ground at Top of Wall
 - Flat Ground at Bottom of Wall
 - No Surcharge on Wall

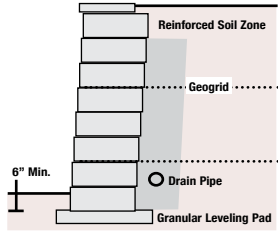

IF STAMPED ENGINEERING IS REQUIRED FOR THIS RETAINING WALL: THIS DESIGN MUST BE STAMPED HERE BY A LICENSED ENGINEER.

GEOGRID PLACEMENT

Note: Grid measurements start from the face of the wall.

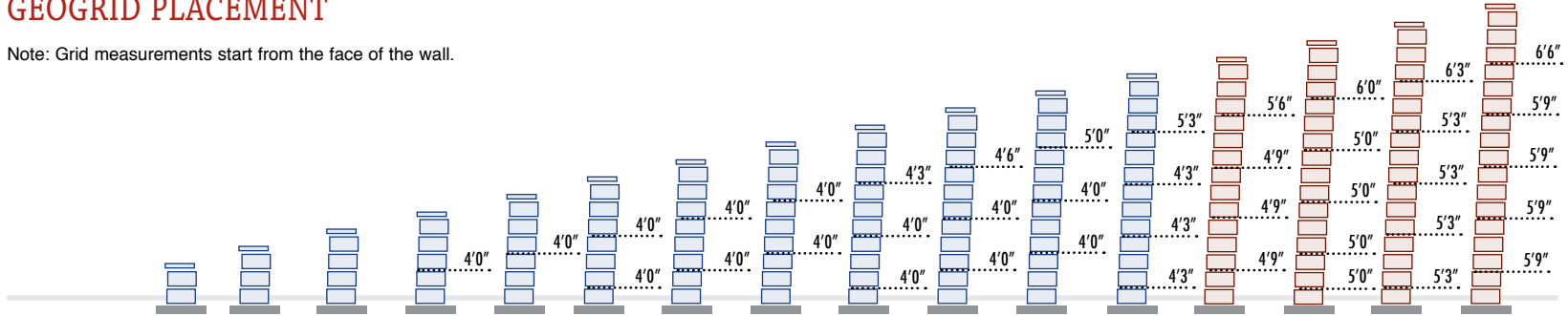

Geogrid Type	SRW Universal - or - SRW 3 Series Grid												SRW 3 Series Grid ONLY			
	0'6"	1'0"	1'6"	2'0"	2'6"	3'0"	3'6"	4'0"	4'6"	5'0"	5'6"	6'0"	6'6"	7'0"	7'6"	8'0"
Exposed Hgt wo/cap	0'6"	1'0"	1'6"	2'0"	2'6"	3'0"	3'6"	4'0"	4'6"	5'0"	5'6"	6'0"	6'6"	7'0"	7'6"	8'0"
Amount Buried	6"	6"	6"	6"	6"	6"	6"	6"	6"	6"	6"	6"	6"	6"	6"	6"
Total Hgt wo/cap	1.0'	1.5'	2'	2.5'	3'	3.5'	4'	4.5'	5'	5.5'	6'	6.5'	7'	7.5'	8'	8.5'
Grid Sq Yd per Ln Ft	0.000	0.000	0.000	0.444	0.444	0.889	0.889	0.889	1.361	1.389	1.444	2.000	2.194	2.889	3.028	3.278
Grid total depth	-	-	-	4.00	4.00	8.00	8.00	8.00	12.25	12.50	13.00	18.00	19.75	26.00	27.25	29.50
Sq Ft Block/Ln Ft	2.40	3.60	4.80	6.00	7.20	8.40	9.60	10.80	12.00	13.20	14.40	15.60	16.80	18.00	19.20	20.40
# Cap per Ln Ft	1.00	1.00	1.00	1.00	1.00	1.00	1.00	1.00	1.00	1.00	1.00	1.00	1.00	1.00	1.00	1.00

See "Material Estimating" for Adhesive estimate

CASE B

- “CASE B” Retaining Wall:**
- Flat Ground at Top of Wall
 - Flat Ground at Bottom of Wall
 - 100 psf Surcharge on Wall

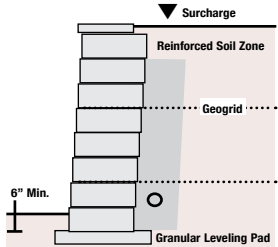

IF STAMPED ENGINEERING IS REQUIRED FOR THIS RETAINING WALL: THIS DESIGN MUST BE STAMPED HERE BY A LICENSED ENGINEER.

GEOGRID PLACEMENT

Note: Grid measurements start from the face of the wall.
• 100 psf Surcharge is light traffic i.e. car or pickup

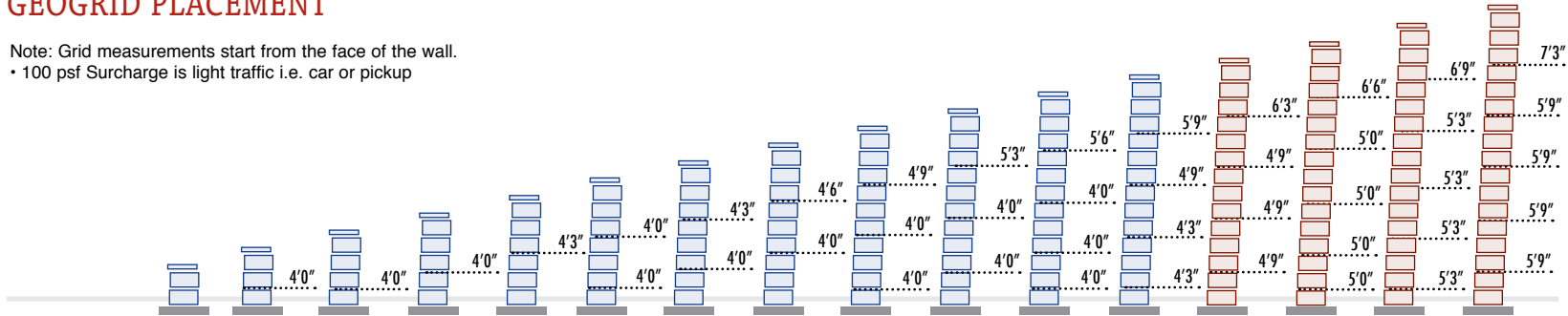

Geogrid Type	SRW Universal - or - SRW 3 Series Grid												SRW 3 Series Grid ONLY			
	0'6"	1'0"	1'6"	2'0"	2'6"	3'0"	3'6"	4'0"	4'6"	5'0"	5'6"	6'0"	6'6"	7'0"	7'6"	8'0"
Exposed Hgt wo/cap	0'6"	1'0"	1'6"	2'0"	2'6"	3'0"	3'6"	4'0"	4'6"	5'0"	5'6"	6'0"	6'6"	7'0"	7'6"	8'0"
Amount Buried	6"	6"	6"	6"	6"	6"	6"	6"	6"	6"	6"	6"	6"	6"	6"	6"
Total Hgt wo/cap	1.0'	1.5'	2'	2.5'	3'	3.5'	4'	4.5'	5'	5.5'	6'	6.5'	7'	7.5'	8'	8.5'
Grid Sq Yd per Ln Ft	0.000	0.444	0.444	0.444	0.472	0.889	0.917	0.944	1.417	1.472	1.944	2.056	2.278	2.944	3.083	3.361
Grid total depth	-	4.00	4.00	4.00	4.25	8.00	8.25	8.50	12.75	13.25	17.50	18.50	20.50	26.50	27.75	30.25
Sq Ft Block/Ln Ft	2.40	3.60	4.80	6.00	7.20	8.40	9.60	10.80	12.00	13.20	14.40	15.60	16.80	18.00	19.20	20.40
# Cap per Ln Ft	1.00	1.00	1.00	1.00	1.00	1.00	1.00	1.00	1.00	1.00	1.00	1.00	1.00	1.00	1.00	1.00

See "Material Estimating" for Adhesive estimate

CASE C

- "CASE C" Retaining Wall:**
- Flat Ground at Top of Wall
 - Flat Ground at Bottom of Wall
 - 250 psf Surcharge on Wall

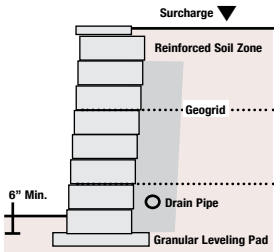

IF STAMPED ENGINEERING IS REQUIRED FOR THIS RETAINING WALL: THIS DESIGN MUST BE STAMPED HERE BY A LICENSED ENGINEER.

GEOGRID PLACEMENT

- Note: Grid measurements start from the face of the wall.
- Surcharge begins two feet behind wall facing.
 - 250 psf Surcharge is heavier traffic i.e. RV, large vehicle

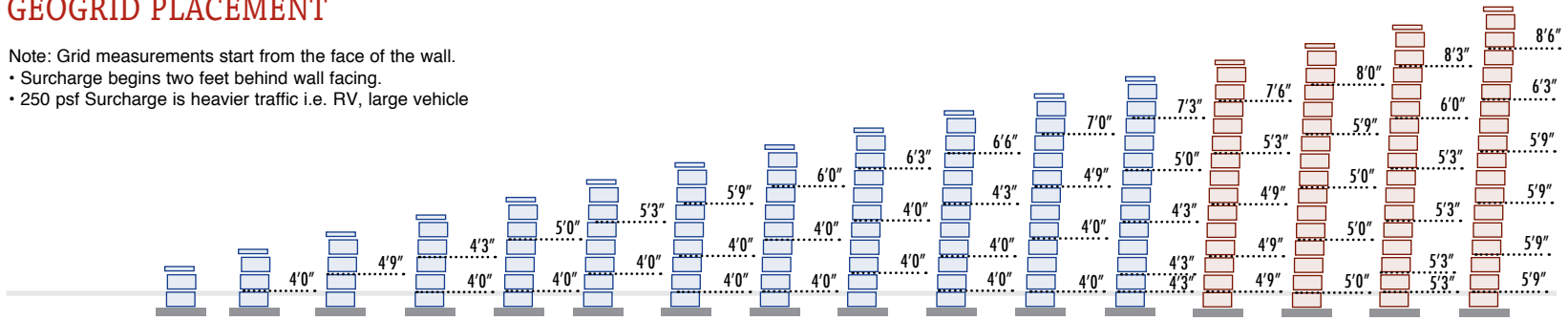

Geogrid Type	SRW Universal - or - SRW 3 Series Grid											SRW 3 Series Grid ONLY				
	0'6"	1'0"	1'6"	2'0"	2'6"	3'0"	3'6"	4'0"	4'6"	5'0"	5'6"	6'0"	6'6"	7'0"	7'6"	8'0"
Exposed Hgt wo/cap	0'6"	1'0"	1'6"	2'0"	2'6"	3'0"	3'6"	4'0"	4'6"	5'0"	5'6"	6'0"	6'6"	7'0"	7'6"	8'0"
Amount Buried	6"	6"	6"	6"	6"	6"	6"	6"	6"	6"	6"	6"	6"	6"	6"	6"
Total Hgt wo/cap	1.0'	1.5'	2'	2.5'	3'	3.5'	4'	4.5'	5'	5.5'	6'	6.5'	7'	7.5'	8'	8.5'
Grid Sq Yd per Ln Ft	0.000	0.444	0.528	0.917	1.000	1.028	1.528	1.556	1.583	2.083	2.194	2.778	3.000	3.194	3.917	4.194
Grid total depth	-	4.00	4.75	8.25	9.00	9.25	13.75	14.00	14.25	18.75	19.75	25.00	27.00	28.75	35.25	37.75
Sq Ft Block/Ln Ft	2.40	3.60	4.80	6.00	7.20	8.40	9.60	10.80	12.00	13.20	14.40	15.60	16.80	18.00	19.20	20.40
# Cap per Ln Ft	1.00	1.00	1.00	1.00	1.00	1.00	1.00	1.00	1.00	1.00	1.00	1.00	1.00	1.00	1.00	1.00

See "Material Estimating" for Adhesive estimate

CASE D

- "CASE D" Retaining Wall:**
- 4/1 Slope at Top of Wall
 - Flat Ground at Bottom of Wall
 - No Surcharge on Wall

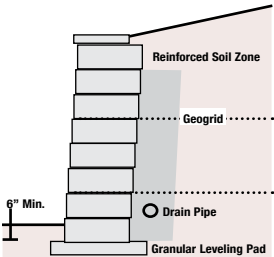

IF STAMPED ENGINEERING IS REQUIRED FOR THIS RETAINING WALL: THIS DESIGN MUST BE STAMPED HERE BY A LICENSED ENGINEER.

GEOGRID PLACEMENT

- Note: Grid measurements start from the face of the wall.

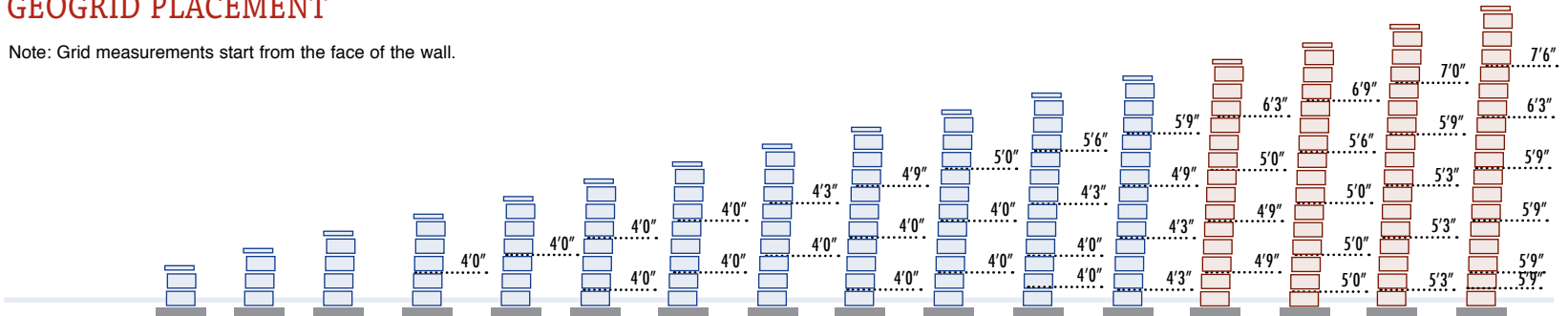

Geogrid Type	SRW Universal - or - SRW 3 Series Grid											SRW 3 Series Grid ONLY				
	0'6"	1'0"	1'6"	2'0"	2'6"	3'0"	3'6"	4'0"	4'6"	5'0"	5'6"	6'0"	6'6"	7'0"	7'6"	8'0"
Exposed Hgt wo/cap	0'6"	1'0"	1'6"	2'0"	2'6"	3'0"	3'6"	4'0"	4'6"	5'0"	5'6"	6'0"	6'6"	7'0"	7'6"	8'0"
Amount Buried	6"	6"	6"	6"	6"	6"	6"	6"	6"	6"	6"	6"	6"	6"	6"	6"
Total Hgt wo/cap	1.0'	1.5'	2'	2.5'	3'	3.5'	4'	4.5'	5'	5.5'	6'	6.5'	7'	7.5'	8'	8.5'
Grid Sq Yd per Ln Ft	0.000	0.000	0.000	0.444	0.444	0.889	0.889	0.917	1.417	1.444	1.972	2.111	2.306	3.028	3.167	4.083
Grid total depth	-	-	-	4.00	4.00	8.00	8.00	8.25	12.75	13.00	17.75	19.00	20.75	27.25	28.50	36.75
Sq Ft Block/Ln Ft	2.40	3.60	4.80	6.00	7.20	8.40	9.60	10.80	12.00	13.20	14.40	15.60	16.80	18.00	19.20	20.40
# Cap per Ln Ft	1.00	1.00	1.00	1.00	1.00	1.00	1.00	1.00	1.00	1.00	1.00	1.00	1.00	1.00	1.00	1.00

See "Material Estimating" for Adhesive estimate

Geogrid: SRW Universal 635 LTDS or SRW 3 Series 1093 LTDS • Block Dimensions: 6"(H) x 8", 10" OR 12" (W) x 10"(D) • Avg Cover: .4167 Sq.Ft.

If used without the stamped engineering, the final determination of the suitability of the contemplated use, and its manner of use, are the sole responsibility of the user, and the user expressly releases HTS, SRW, and retaining wall unit supplier of any and all liability that might arise as a result. These designs have been performed with National Concrete Masonry Association (NCMA) software and have been analyzed for the appropriate factors of safety. © 2009 Hardscape Technical Services • Maytrx® is a registered trademark of Maytrx Premier Stone System.



28 DEGREE SOIL

for walls up to 8'

Maytrx® Block • SRW Accessories

28 DEGREE SOIL for walls up to 8'

Maytrx® Block • SRW Accessories

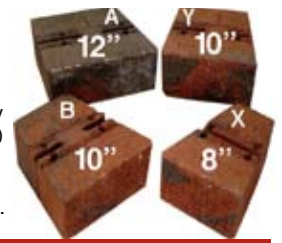

If used without the stamped engineering, the final determination of the suitability of the contemplated use, and its manner of use, are the sole responsibility of the user, and the user expressly releases HTS, SRW, and retaining wall unit supplier of any and all liability that might arise as a result. These designs have been performed with National Concrete Masonry Association (NCMA) software and have been analyzed for the appropriate factors of safety. © 2009 Hardscape Technical Services • Maytrx® is a registered trademark of Maytrx Premier Stone System.

Geogrid: SRW Universal 635 LTDS or SRW 3 Series 1093 LTDS • Block Dimensions: 6"(H) x 8", 10" OR 12" (W) x 10"(D) • Avg Cover: .4167 Sq.Ft.

CASE E

- "CASE E" Retaining Wall:**
- 2.5/1 Slope at Top of Wall
 - Flat Ground at Bottom of Wall
 - No Surcharge on Wall

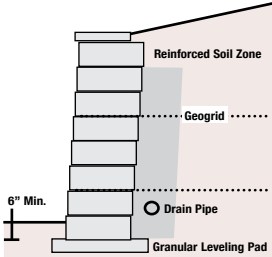

IF STAMPED ENGINEERING IS REQUIRED FOR THIS RETAINING WALL: THIS DESIGN MUST BE STAMPED HERE BY A LICENSED ENGINEER.

GEOGRID PLACEMENT

Note: Grid measurements start from the face of the wall.

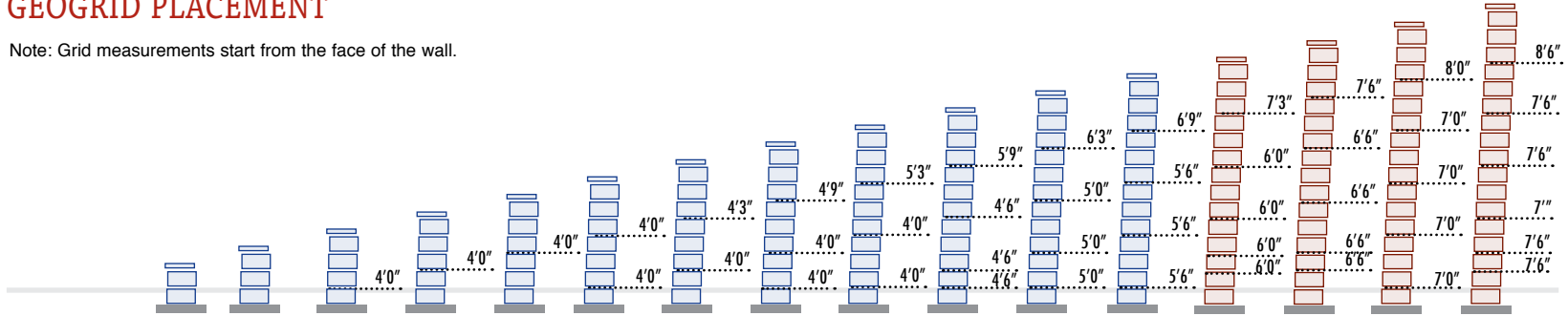

Geogrid Type	SRW Universal - or - SRW 3 Series Grid												SRW 3 Series Grid ONLY			
	0'6"	1'0"	1'6"	2'0"	2'6"	3'0"	3'6"	4'0"	4'6"	5'0"	5'6"	6'0"	6'6"	7'0"	7'6"	8'0"
Exposed Hgt wo/cap	0'6"	1'0"	1'6"	2'0"	2'6"	3'0"	3'6"	4'0"	4'6"	5'0"	5'6"	6'0"	6'6"	7'0"	7'6"	8'0"
Amount Buried	6"	6"	6"	6"	6"	6"	6"	6"	6"	6"	6"	6"	6"	6"	6"	6"
Total Hgt wo/cap	1.0'	1.5'	2'	2.5'	3'	3.5'	4'	4.5'	5'	5.5'	6'	6.5'	7'	7.5'	8'	8.5'
Grid Sq Yd per Ln Ft	0.000	0.000	0.444	0.444	0.444	0.889	0.917	1.417	1.472	2.139	2.361	2.583	3.472	3.722	4.000	5.111
Grid total depth	-	-	4.00	4.00	4.00	8.00	8.25	12.75	13.25	19.25	21.25	23.25	31.25	33.50	36.00	46.00
Sq Ft Block/Ln Ft	2.40	3.60	4.80	6.00	7.20	8.40	9.60	10.80	12.00	13.20	14.40	15.60	16.80	18.00	19.20	20.40
# Cap per Ln Ft	1.00	1.00	1.00	1.00	1.00	1.00	1.00	1.00	1.00	1.00	1.00	1.00	1.00	1.00	1.00	1.00

See "Material Estimating" for Adhesive estimate

CASE F

- "CASE F" Retaining Wall:**
- Flat Ground at Top of Wall
 - 5/1 Slope at Bottom of Wall
 - No Surcharge on Wall

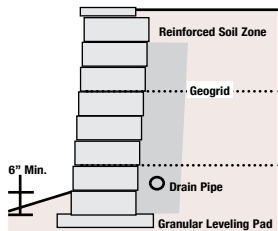

IF STAMPED ENGINEERING IS REQUIRED FOR THIS RETAINING WALL: THIS DESIGN MUST BE STAMPED HERE BY A LICENSED ENGINEER.

GEOGRID PLACEMENT

Note: Grid measurements start from the face of the wall.

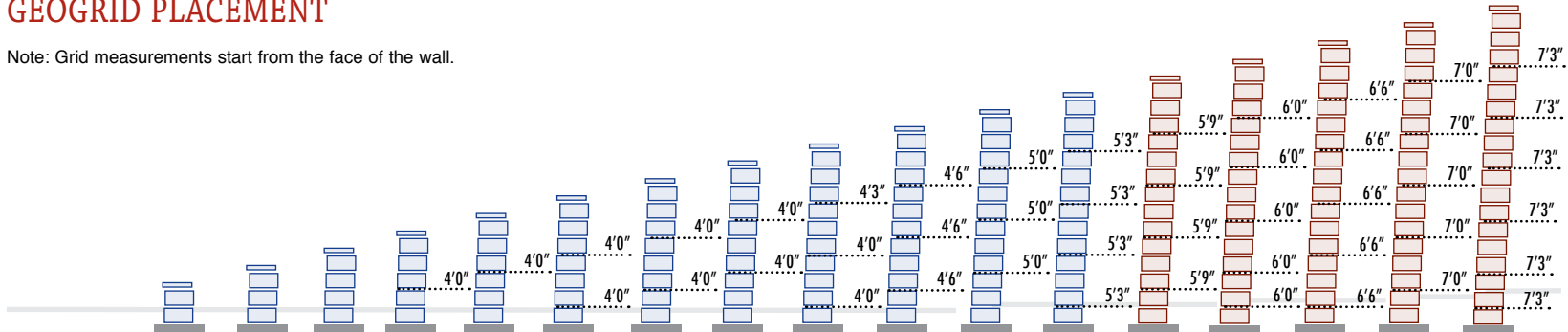

Geogrid Type	SRW Universal - or - SRW 3 Series Grid												SRW 3 Series Grid ONLY				
	0'6"	1'0"	1'6"	2'0"	2'6"	3'0"	3'6"	4'0"	4'6"	5'0"	5'5"	5'10"	6'4"	6'9"	7'3"	7'8"	8'0"
Exposed Hgt wo/cap	0'6"	1'0"	1'6"	2'0"	2'6"	3'0"	3'6"	4'0"	4'6"	5'0"	5'5"	5'10"	6'4"	6'9"	7'3"	7'8"	8'0"
Amount Buried	6"	6"	6"	6"	6"	6"	6"	6"	6"	6"	7"	8"	8"	9"	9"	10"	10"
Total Hgt wo/cap	1.0'	1.5'	2'	2.5'	3'	3.5'	4'	4.5'	5'	5.5'	6'	6.5'	7'	7.5'	8'	8.5'	9'
Grid Sq Yd per Ln Ft	0.000	0.000	0.000	0.444	0.444	0.889	0.889	0.889	1.361	1.500	1.667	2.333	2.556	3.333	3.611	3.889	4.833
Grid total depth	-	-	-	4.00	4.00	8.00	8.00	8.00	12.25	13.50	15.00	21.00	23.00	30.00	32.50	35.00	43.50
Sq Ft Block/Ln Ft	2.40	3.60	4.80	6.00	7.20	8.40	9.60	10.80	12.00	13.20	14.40	15.60	16.80	18.00	19.20	20.40	21.60
# Cap per Ln Ft	1.00	1.00	1.00	1.00	1.00	1.00	1.00	1.00	1.00	1.00	1.00	1.00	1.00	1.00	1.00	1.00	1.00

See "Material Estimating" for Adhesive estimate

CASE G

- "CASE G" Retaining Wall:**
- Flat Ground at Top of Wall
 - 5/1 Slope at Bottom of Wall
 - 100 psf Surcharge on Wall

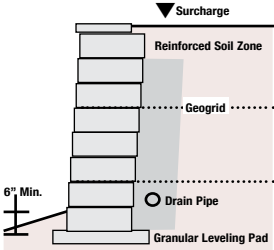

IF STAMPED ENGINEERING IS REQUIRED FOR THIS RETAINING WALL: THIS DESIGN MUST BE STAMPED HERE BY A LICENSED ENGINEER.

GEOGRID PLACEMENT

Note: Grid measurements start from the face of the wall.
 • 100 psf Surcharge is light traffic i.e. car or pickup

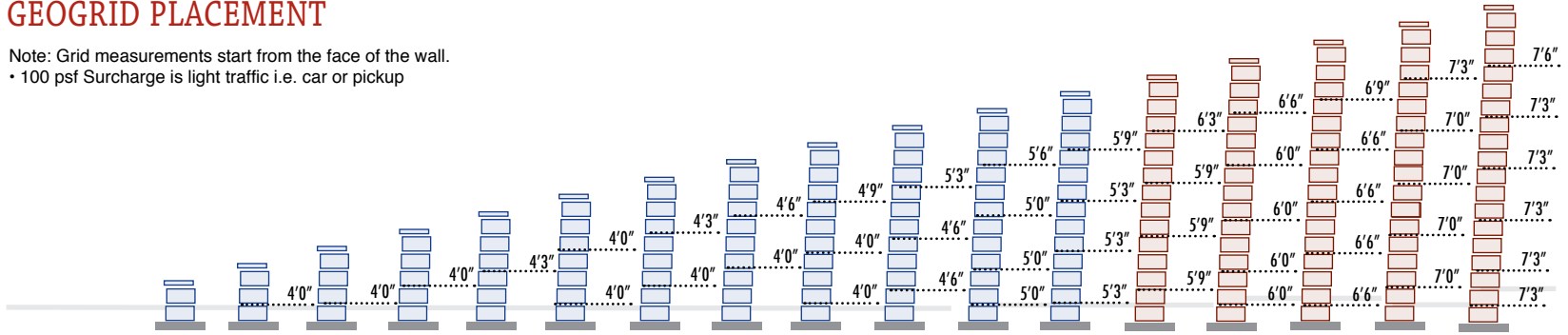

Geogrid Type	SRW Universal - or - SRW 3 Series Grid												SRW 3 Series Grid ONLY				
	0'6"	1'0"	1'6"	2'0"	2'6"	3'0"	3'6"	4'0"	4'6"	5'0"	5'5"	5'10"	6'4"	6'9"	7'3"	7'8"	8'0"
Exposed Hgt wo/cap	0'6"	1'0"	1'6"	2'0"	2'6"	3'0"	3'6"	4'0"	4'6"	5'0"	5'5"	5'10"	6'4"	6'9"	7'3"	7'8"	8'0"
Amount Buried	6"	6"	6"	6"	6"	6"	6"	6"	6"	6"	7"	8"	8"	9"	9"	10"	1'0"
Total Hgt wo/cap	1.0'	1.5'	2'	2.5'	3'	3.5'	4'	4.5'	5'	5.5'	6'	6.5'	7'	7.5'	8'	8.5'	9'
Grid Sq Yd per Ln Ft	0.000	0.444	0.444	0.444	0.472	0.889	0.917	0.944	1.417	1.583	2.278	2.389	2.611	3.389	3.639	3.917	4.861
Grid total depth	-	4.00	4.00	4.00	4.25	8.00	8.25	8.50	12.75	14.25	20.50	21.50	23.50	30.50	32.75	35.25	43.75
Sq Ft Block/Ln Ft	2.40	3.60	4.80	6.00	7.20	8.40	9.60	10.80	12.00	13.20	14.40	15.60	16.80	18.00	19.20	20.40	21.60
# Cap per Ln Ft	1.00	1.00	1.00	1.00	1.00	1.00	1.00	1.00	1.00	1.00	1.00	1.00	1.00	1.00	1.00	1.00	1.00

See "Material Estimating" for Adhesive estimate

CASE H

- "CASE H" Retaining Wall:**
- Flat Ground at Top of Wall
 - 5/1 Slope at Bottom of Wall
 - 250 psf Surcharge on Wall

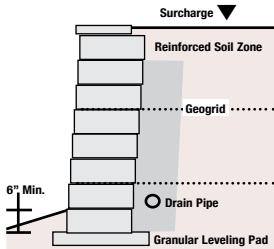

IF STAMPED ENGINEERING IS REQUIRED FOR THIS RETAINING WALL: THIS DESIGN MUST BE STAMPED HERE BY A LICENSED ENGINEER.

GEOGRID PLACEMENT

Note: Grid measurements start from the face of the wall.
 • Surcharge begins two feet behind wall facing.
 • 250 psf Surcharge is heavier traffic i.e. RV, large vehicle

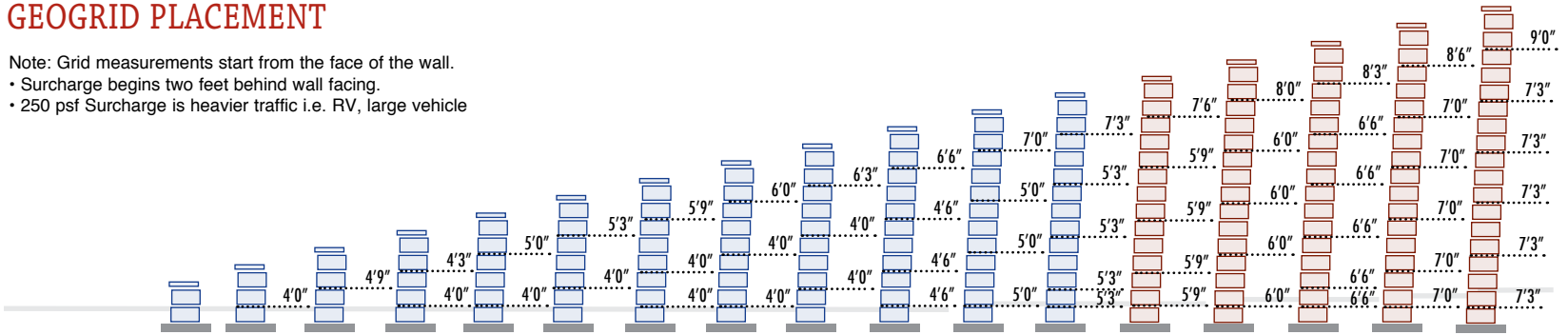

Geogrid Type	SRW Universal - or - SRW 3 Series Grid												SRW 3 Series Grid ONLY				
	0'6"	1'0"	1'6"	2'0"	2'6"	3'0"	3'6"	4'0"	4'6"	5'0"	5'5"	5'10"	6'4"	6'9"	7'3"	7'8"	8'0"
Exposed Hgt wo/cap	0'6"	1'0"	1'6"	2'0"	2'6"	3'0"	3'6"	4'0"	4'6"	5'0"	5'5"	5'10"	6'4"	6'9"	7'3"	7'8"	8'0"
Amount Buried	6"	6"	6"	6"	6"	6"	6"	6"	6"	6"	7"	8"	8"	9"	9"	10"	1'0"
Total Hgt wo/cap	1.0'	1.5'	2'	2.5'	3'	3.5'	4'	4.5'	5'	5.5'	6'	6.5'	7'	7.5'	8'	8.5'	9'
Grid Sq Yd per Ln Ft	0.000	0.444	0.528	0.917	1.000	1.028	1.528	1.556	1.583	2.222	2.444	3.139	3.389	3.556	4.528	4.833	5.028
Grid total depth	-	4.00	4.75	8.25	9.00	9.25	13.75	14.00	14.25	20.00	22.00	28.25	30.50	32.00	40.75	43.50	45.25
Sq Ft Block/Ln Ft	2.40	3.60	4.80	6.00	7.20	8.40	9.60	10.80	12.00	13.20	14.40	15.60	16.80	18.00	19.20	20.40	21.60
# Cap per Ln Ft	1.00	1.00	1.00	1.00	1.00	1.00	1.00	1.00	1.00	1.00	1.00	1.00	1.00	1.00	1.00	1.00	1.00

See "Material Estimating" for Adhesive estimate

Geogrid: SRW Universal 635 LTDS or SRW 3 Series 1093 LTDS • Block Dimensions: 6"(H) x 8", 10" OR 12" (W) x 10"(D) • Avg Cover: .4167 Sq.Ft.

If used without the stamped engineering, the final determination of the suitability of the contemplated use, and its manner of use, are the sole responsibility of the user, and the user expressly releases HTS, SRW, and retaining wall unit supplier of any and all liability that might arise as a result. These designs have been performed with National Concrete Masonry Association (NCMA) software and have been analyzed for the appropriate factors of safety. © 2009 Hardscape Technical Services • Maytrx® is a registered trademark of Maytrx Premier Stone System.

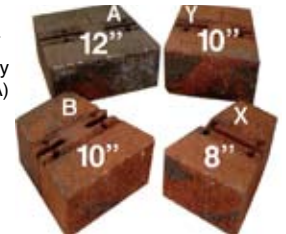

28 DEGREE SOIL

for walls up to 8'

Maytrx® Block • SRW Accessories

28 DEGREE SOIL for walls up to 8'

Maytrx® Block • SRW Accessories

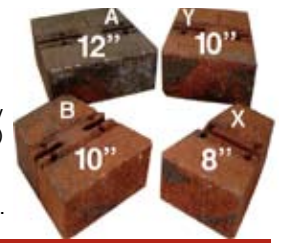

If used without the stamped engineering, the final determination of the suitability of the contemplated use, and its manner of use, are the sole responsibility of the user, and the user expressly releases HTS, SRW, and retaining wall unit supplier of any and all liability that might arise as a result. These designs have been performed with National Concrete Masonry Association (NCMA) software and have been analyzed for the appropriate factors of safety. © 2009 Hardscape Technical Services • Maytrx® is a registered trademark of Maytrx Premier Stone System.

Geogrid: SRW Universal 635 LTDS or SRW 3 Series 1093 LTDS • Block Dimensions: 6\"/>

CASE I

- “CASE I” Retaining Wall:**
- Flat Ground at Top of Wall
 - 4/1 Slope at Bottom of Wall
 - No Surcharge on Wall

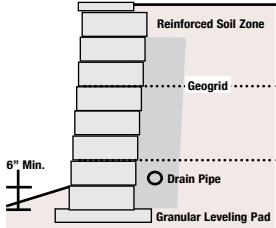

IF STAMPED ENGINEERING IS REQUIRED FOR THIS RETAINING WALL: THIS DESIGN MUST BE STAMPED HERE BY A LICENSED ENGINEER.

GEOGRID PLACEMENT

Note: Grid measurements start from the face of the wall.

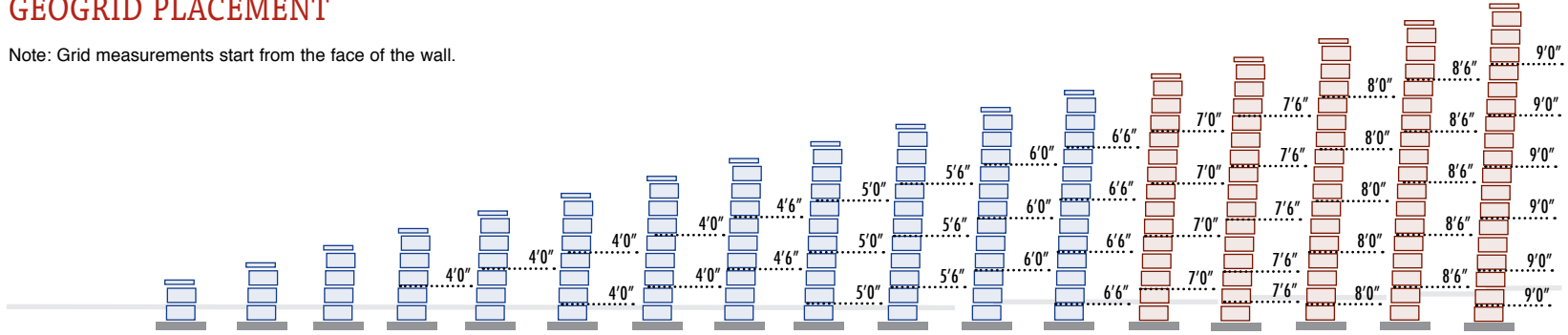

Geogrid Type	SRW Universal - or - SRW 3 Series Grid												SRW 3 Series Grid ONLY				
	0'6"	1'0"	1'6"	2'0"	2'6"	3'0"	3'6"	4'0"	4'6"	5'0"	5'5"	5'10"	6'4"	6'9"	7'3"	7'8"	8'0"
Exposed Hgt wo/cap	0'6"	1'0"	1'6"	2'0"	2'6"	3'0"	3'6"	4'0"	4'6"	5'0"	5'5"	5'10"	6'4"	6'9"	7'3"	7'8"	8'0"
Amount Buried	6"	6"	6"	6"	6"	6"	6"	6"	6"	7"	8"	8"	8"	9"	9"	10"	10"
Total Hgt wo/cap	1.0'	1.5'	2'	2.5'	3'	3.5'	4'	4.5'	5'	5.5'	6'	6.5'	7'	7.5'	8'	8.5'	9'
Grid Sq Yd per Ln Ft	0.000	0.000	0.000	0.444	0.444	0.889	0.889	1.000	1.667	1.833	2.000	2.889	3.111	4.167	4.444	4.722	6.000
Grid total depth	-	-	-	4.00	4.00	8.00	8.00	9.00	15.00	16.50	18.00	26.00	28.00	37.50	40.00	42.50	54.00
Sq Ft Block/Ln Ft	2.40	3.60	4.80	6.00	7.20	8.40	9.60	10.80	12.00	13.20	14.40	15.60	16.80	18.00	19.20	10.40	21.60
# Cap per Ln Ft	1.00	1.00	1.00	1.00	1.00	1.00	1.00	1.00	1.00	1.00	1.00	1.00	1.00	1.00	1.00	1.00	1.00

See "Material Estimating" for Adhesive estimate

CASE J

- “CASE J” Retaining Wall:**
- Flat Ground at Top of Wall
 - 4/1 Slope at Bottom of Wall
 - 100 psf Surcharge on Wall

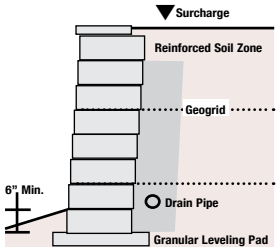

IF STAMPED ENGINEERING IS REQUIRED FOR THIS RETAINING WALL: THIS DESIGN MUST BE STAMPED HERE BY A LICENSED ENGINEER.

GEOGRID PLACEMENT

Note: Grid measurements start from the face of the wall.
• 100 psf Surcharge is light traffic i.e. car or pickup

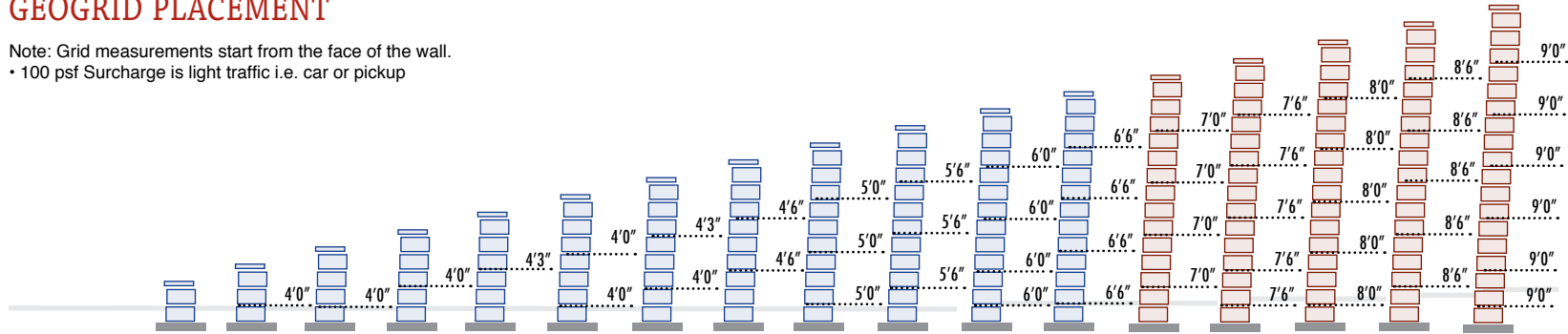

Geogrid Type	SRW Universal - or - SRW 3 Series Grid												SRW 3 Series Grid ONLY				
	0'6"	1'0"	1'6"	2'0"	2'6"	3'0"	3'6"	4'0"	4'6"	5'0"	5'5"	5'10"	6'4"	6'9"	7'3"	7'8"	8'0"
Exposed Hgt wo/cap	0'6"	1'0"	1'6"	2'0"	2'6"	3'0"	3'6"	4'0"	4'6"	5'0"	5'5"	5'10"	6'4"	6'9"	7'3"	7'8"	8'0"
Amount Buried	6"	6"	6"	6"	6"	6"	6"	6"	6"	7"	8"	8"	8"	9"	9"	10"	10"
Total Hgt wo/cap	1.0'	1.5'	2'	2.5'	3'	3.5'	4'	4.5'	5'	5.5'	6'	6.5'	7'	7.5'	8'	8.5'	9'
Grid Sq Yd per Ln Ft	0.000	0.444	0.444	0.444	0.472	0.889	0.917	1.000	1.667	1.883	2.667	2.889	3.111	4.167	4.444	4.722	6.000
Grid total depth	-	4.00	4.00	4.00	4.25	8.00	8.25	9.00	15.00	16.50	24.00	26.00	28.00	37.50	40.00	42.50	54.00
Sq Ft Block/Ln Ft	2.40	3.60	4.80	6.00	7.20	8.40	9.60	10.80	12.00	13.20	14.40	15.60	16.80	18.00	19.20	20.40	21.60
# Cap per Ln Ft	1.00	1.00	1.00	1.00	1.00	1.00	1.00	1.00	1.00	1.00	1.00	1.00	1.00	1.00	1.00	1.00	1.00

See "Material Estimating" for Adhesive estimate

CASE K

- "CASE K" Retaining Wall:**
- Flat Ground at Top of Wall
 - 4/1 Slope at Bottom of Wall
 - 250 psf Surcharge on Wall

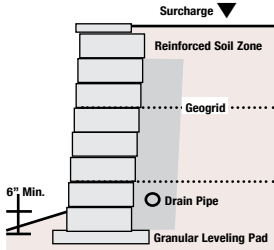

IF STAMPED ENGINEERING IS REQUIRED FOR THIS RETAINING WALL: THIS DESIGN MUST BE STAMPED HERE BY A LICENSED ENGINEER.

GEOGRID PLACEMENT

- Note: Grid measurements start from the face of the wall.
- Surcharge begins two feet behind wall facing.
 - 250 psf Surcharge is heavier traffic i.e. RV, large vehicle

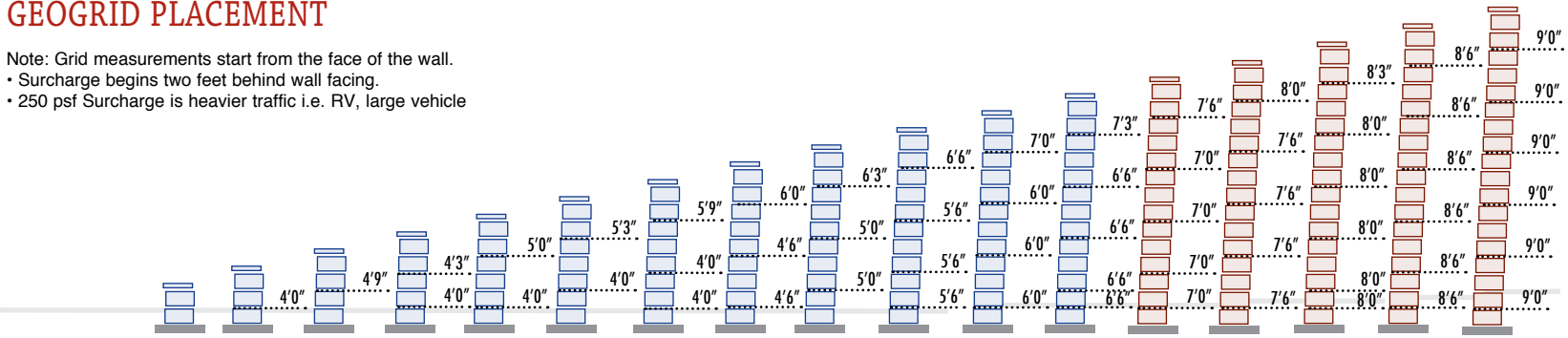

Geogrid Type	SRW Universal - or - SRW 3 Series Grid												SRW 3 Series Grid ONLY				
Exposed Hgt wo/cap	0'6"	1'0"	1'6"	2'0"	2'6"	3'0"	3'6"	4'0"	4'6"	5'0"	5'5"	5'10"	6'4"	6'9"	7'3"	7'8"	8'0"
Amount Buried	6"	6"	6"	6"	6"	6"	6"	6"	6"	6"	7"	8"	8"	9"	9"	10"	1'0"
Total Hgt wo/cap	1.0'	1.5'	2'	2.5'	3'	3.5'	4'	4.5'	5'	5.5'	6'	6.5'	7'	7.5'	8'	8.5'	9'
Grid Sq Yd per Ln Ft	0.000	0.444	0.528	0.917	1.000	1.028	1.528	1.667	1.806	2.556	2.778	3.694	3.944	4.222	5.361	5.667	6.000
Grid total depth	-	4.00	4.75	8.25	9.00	9.25	13.75	15.00	16.25	23.00	25.00	33.25	35.50	38.00	48.25	51.00	54.00
Sq Ft Block/Ln Ft	2.40	3.60	4.80	6.00	7.20	8.40	9.60	10.80	12.00	13.20	14.40	15.60	16.80	18.00	19.20	20.40	21.60
# Cap per Ln Ft	1.00	1.00	1.00	1.00	1.00	1.00	1.00	1.00	1.00	1.00	1.00	1.00	1.00	1.00	1.00	1.00	1.00

See "Material Estimating" for Adhesive estimate

CASE L

- "CASE L" Retaining Wall:**
- Flat Ground at Top of Wall
 - 3/1 Slope at Bottom of Wall
 - No Surcharge on Wall

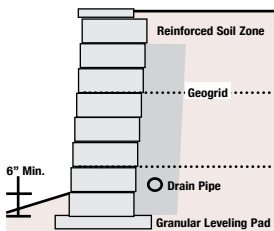

IF STAMPED ENGINEERING IS REQUIRED FOR THIS RETAINING WALL: THIS DESIGN MUST BE STAMPED HERE BY A LICENSED ENGINEER.

GEOGRID PLACEMENT

- Note: Grid measurements start from the face of the wall.

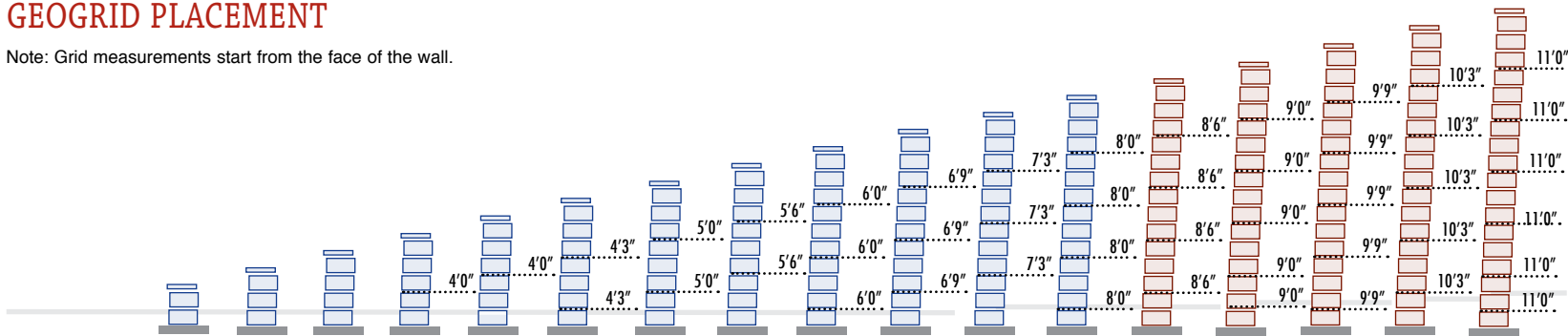

Geogrid Type	SRW Universal - or - SRW 3 Series Grid												SRW 3 Series Grid ONLY				
Exposed Hgt wo/cap	0'6"	1'0"	1'6"	2'0"	2'6"	3'0"	3'6"	4'0"	4'6"	5'0"	5'5"	5'10"	6'4"	6'9"	7'3"	7'8"	8'0"
Amount Buried	6"	6"	6"	6"	6"	6"	6"	6"	6"	6"	7"	8"	8"	9"	9"	10"	1'0"
Total Hgt wo/cap	1.0'	1.5'	2'	2.5'	3'	3.5'	4'	4.5'	5'	5.5'	6'	6.5'	7'	7.5'	8'	8.5'	9'
Grid Sq Yd per Ln Ft	0.000	0.000	0.000	0.444	0.444	0.944	1.111	1.222	2.000	2.250	2.417	3.556	3.778	5.000	5.417	5.694	7.333
Grid total depth	-	-	-	4.00	4.00	8.50	10.00	11.00	18.00	20.25	21.75	32.00	34.00	45.00	48.75	51.25	66.00
Sq Ft Block/Ln Ft	2.40	3.60	4.80	6.00	7.20	8.40	9.60	10.80	12.00	13.20	14.40	15.60	16.80	18.00	19.20	20.40	21.60
# Cap per Ln Ft	1.00	1.00	1.00	1.00	1.00	1.00	1.00	1.00	1.00	1.00	1.00	1.00	1.00	1.00	1.00	1.00	1.00

See "Material Estimating" for Adhesive estimate

Geogrid: SRW Universal 635 LTDS or SRW 3 Series 1093 LTDS • Block Dimensions: 6"(H) x 8", 10" OR 12" (W) x 10"(D) • Avg Cover: .4167 Sq.Ft.

If used without the stamped engineering, the final determination of the suitability of the contemplated use, and its manner of use, are the sole responsibility of the user, and the user expressly releases HTS, SRW, and retaining wall unit supplier of any and all liability that might arise as a result. These designs have been performed with National Concrete Masonry Association (NCMA) software and have been analyzed for the appropriate factors of safety. © 2009 Hardscape Technical Services • Maytrx® is a registered trademark of Maytrx Premier Stone System.



28 DEGREE SOIL

for walls up to 8'

Maytrx® Block • SRW Accessories

28 DEGREE SOIL for walls up to 8'

Maytrx® Block • SRW Accessories

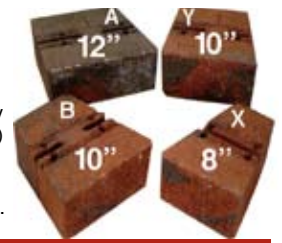

If used without the stamped engineering, the final determination of the suitability of the contemplated use, and its manner of use, are the sole responsibility of the user, and the user expressly releases HTS, SRW, and retaining wall unit supplier of any and all liability that might arise as a result. These designs have been performed with National Concrete Masonry Association (NCMA) software and have been analyzed for the appropriate factors of safety. © 2009 Hardscape Technical Services • Maytrx® is a registered trademark of Maytrx Premier Stone System.

Geogrid: SRW Universal 635 LTDS or SRW 3 Series 1093 LTDS • Block Dimensions: 6"(H) x 8", 10" OR 12" (W) x 10"(D) • Avg Cover: .4167 Sq.Ft.

CASE M

- "CASE M" Retaining Wall:**
- Flat Ground at Top of Wall
 - 3/1 Slope at Bottom of Wall
 - 100 psf Surcharge on Wall

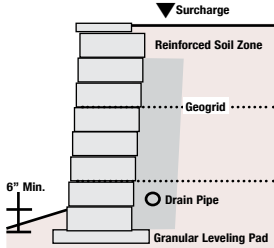

IF STAMPED ENGINEERING IS REQUIRED FOR THIS RETAINING WALL: THIS DESIGN MUST BE STAMPED HERE BY A LICENSED ENGINEER.

GEOGRID PLACEMENT

- Note: Grid measurements start from the face of the wall.
- 100 psf Surcharge is light traffic i.e. car or pickup

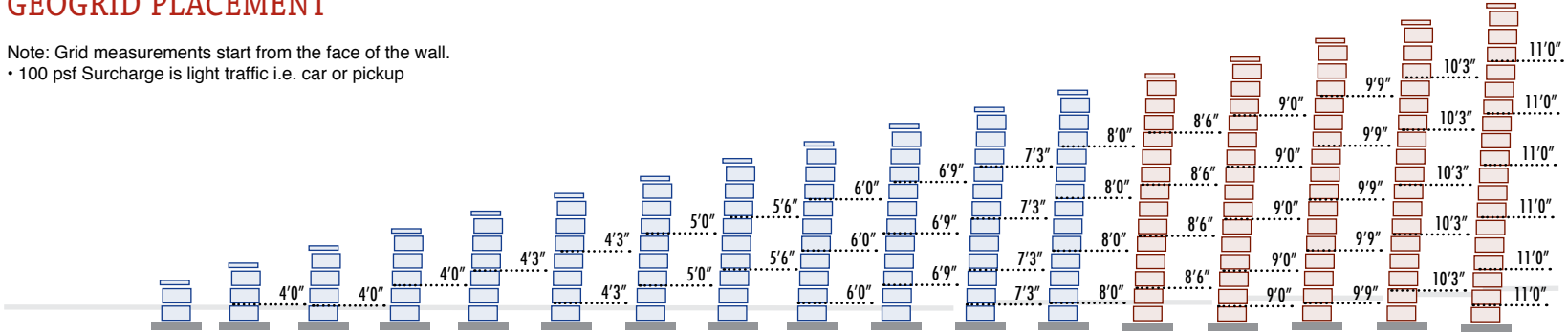

Geogrid Type	SRW Universal - or - SRW 3 Series Grid												SRW 3 Series Grid ONLY				
	0'6"	1'0"	1'6"	2'0"	2'6"	3'0"	3'6"	4'0"	4'6"	5'0"	5'5"	5'10"	6'4"	6'9"	7'3"	7'8"	8'0"
Exposed Hgt wo/cap	0'6"	1'0"	1'6"	2'0"	2'6"	3'0"	3'6"	4'0"	4'6"	5'0"	5'5"	5'10"	6'4"	6'9"	7'3"	7'8"	8'0"
Amount Buried	6"	6"	6"	6"	6"	6"	6"	6"	6"	6"	7"	8"	8"	9"	9"	10"	1'0"
Total Hgt wo/cap	1.0'	1.5'	2'	2.5'	3'	3.5'	4'	4.5'	5'	5.5'	6'	6.5'	7'	7.5'	8'	8.5'	9'
Grid Sq Yd per Ln Ft	0.000	0.444	0.444	0.444	0.472	0.944	1.111	1.222	2.000	2.250	3.222	3.556	3.778	5.000	5.417	5.694	7.333
Grid total depth	-	4.00	4.00	4.00	4.25	8.50	10.00	11.00	18.00	20.25	29.00	32.00	34.00	45.00	48.75	51.25	66.00
Sq Ft Block/Ln Ft	2.40	3.60	4.80	6.00	7.20	8.40	9.60	10.80	12.00	13.20	14.40	15.60	16.80	18.00	19.20	20.40	21.60
# Cap per Ln Ft	1.00	1.00	1.00	1.00	1.00	1.00	1.00	1.00	1.00	1.00	1.00	1.00	1.00	1.00	1.00	1.00	1.00

See "Material Estimating" for Adhesive estimate

CASE N

- "CASE N" Retaining Wall:**
- Flat Ground at Top of Wall
 - 3/1 Slope at Bottom of Wall
 - 250 psf Surcharge on Wall

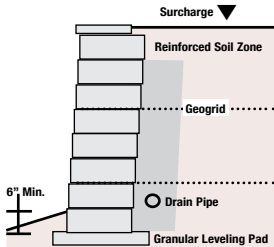

IF STAMPED ENGINEERING IS REQUIRED FOR THIS RETAINING WALL: THIS DESIGN MUST BE STAMPED HERE BY A LICENSED ENGINEER.

GEOGRID PLACEMENT

- Note: Grid measurements start from the face of the wall.
- Surcharge begins two feet behind wall facing.
 - 250 psf Surcharge is heavier traffic i.e. RV, large vehicle

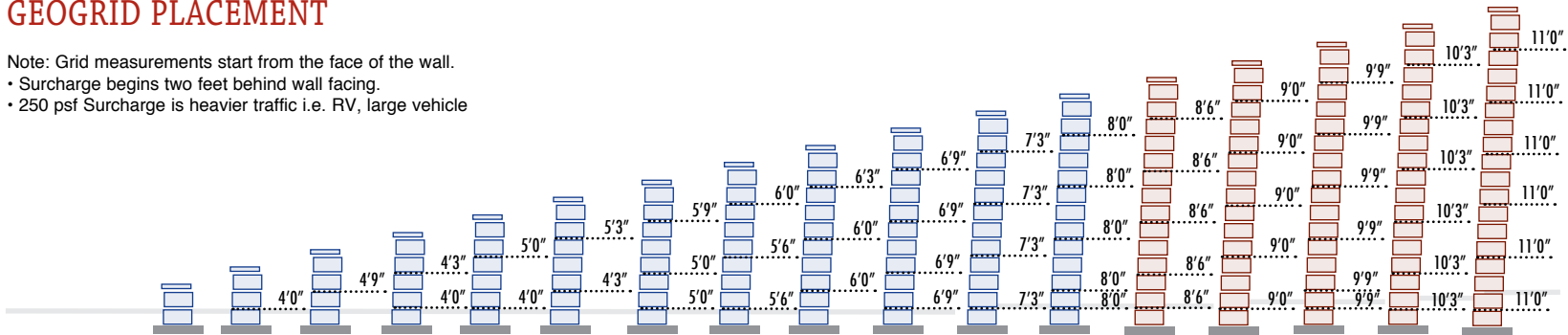

Geogrid Type	SRW Universal - or - SRW 3 Series Grid												SRW 3 Series Grid ONLY				
	0'6"	1'0"	1'6"	2'0"	2'6"	3'0"	3'6"	4'0"	4'6"	5'0"	5'5"	5'10"	6'4"	6'9"	7'3"	7'8"	8'0"
Exposed Hgt wo/cap	0'6"	1'0"	1'6"	2'0"	2'6"	3'0"	3'6"	4'0"	4'6"	5'0"	5'5"	5'10"	6'4"	6'9"	7'3"	7'8"	8'0"
Amount Buried	6"	6"	6"	6"	6"	6"	6"	6"	6"	6"	7"	8"	8"	9"	9"	10"	1'0"
Total Hgt wo/cap	1.0'	1.5'	2'	2.5'	3'	3.5'	4'	4.5'	5'	5.5'	6'	6.5'	7'	7.5'	8'	8.5'	9'
Grid Sq Yd per Ln Ft	0.000	0.444	0.528	0.917	1.000	1.056	1.750	1.889	2.028	3.000	3.222	4.444	4.722	5.000	6.500	6.833	7.333
Grid total depth	-	4.00	4.75	8.25	9.00	9.50	15.75	17.00	18.25	27.00	29.00	40.00	42.50	45.00	58.50	61.50	66.00
Sq Ft Block/Ln Ft	2.40	3.60	4.80	6.00	7.20	8.40	9.60	10.80	12.00	13.20	14.40	15.60	16.80	18.00	19.20	20.40	21.60
# Cap per Ln Ft	1.00	1.00	1.00	1.00	1.00	1.00	1.00	1.00	1.00	1.00	1.00	1.00	1.00	1.00	1.00	1.00	1.00

See "Material Estimating" for Adhesive estimate

CASE A

- "CASE A" Retaining Wall:**
- Flat Ground at Top of Wall
 - Flat Ground at Bottom of Wall
 - No Surcharge on Wall

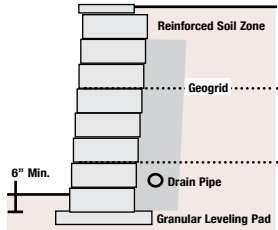

IF STAMPED ENGINEERING IS REQUIRED FOR THIS RETAINING WALL: THIS DESIGN MUST BE STAMPED HERE BY A LICENSED ENGINEER.

GEOGRID PLACEMENT

Note: Grid measurements start from the face of the wall.

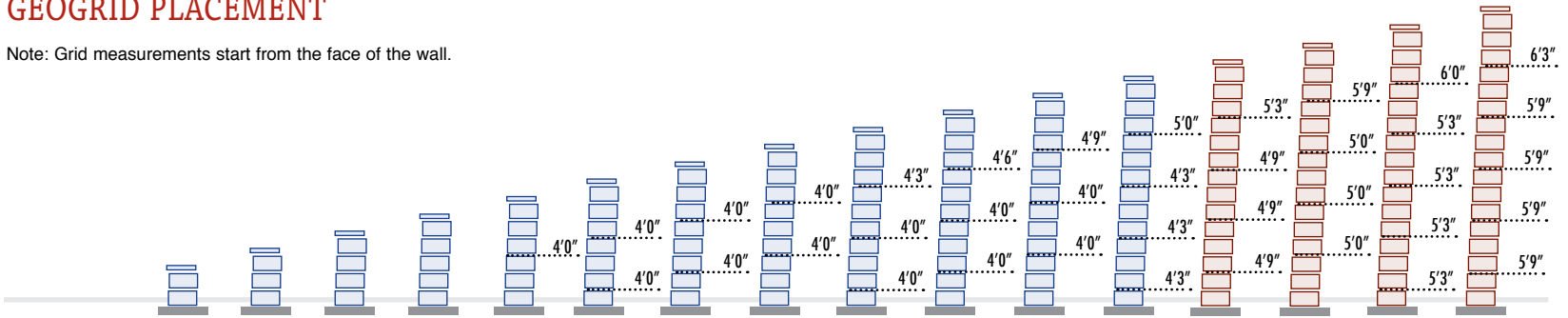

Geogrid Type	SRW Universal - or - SRW 3 Series Grid												SRW 3 Series Grid ONLY			
	0'6"	1'0"	1'6"	2'0"	2'6"	3'0"	3'6"	4'0"	4'6"	5'0"	5'6"	6'0"	6'6"	7'0"	7'6"	8'0"
Exposed Hgt wo/cap	0'6"	1'0"	1'6"	2'0"	2'6"	3'0"	3'6"	4'0"	4'6"	5'0"	5'6"	6'0"	6'6"	7'0"	7'6"	8'0"
Amount Buried	6"	6"	6"	6"	6"	6"	6"	6"	6"	6"	6"	6"	6"	6"	6"	6"
Total Hgt wo/cap	1'0"	1'5"	2'	2'5"	3'	3'5"	4'	4'5"	5'	5'5"	6'	6'5"	7'	7'5"	8'	8'5"
Grid Sq Yd per Ln Ft	0.000	0.000	0.000	0.000	0.444	0.889	0.889	0.889	1.361	1.389	1.417	1.972	2.167	2.306	3.000	3.250
Grid total depth	-	-	-	-	4'0"	8'0"	8'0"	8'0"	12'25"	12'50"	12'75"	17'75"	19'50"	20'75"	27'00"	29'25"
Sq Ft Block/Ln Ft	2.40	3.60	4.80	6.00	7.20	8.40	9.60	10.80	12.00	13.20	14.40	15.60	16.80	18.00	19.20	20.40
# Cap per Ln Ft	1.00	1.00	1.00	1.00	1.00	1.00	1.00	1.00	1.00	1.00	1.00	1.00	1.00	1.00	1.00	1.00

See "Material Estimating" for Adhesive estimate

CASE B

- "CASE B" Retaining Wall:**
- Flat Ground at Top of Wall
 - Flat Ground at Bottom of Wall
 - 100 psf Surcharge on Wall

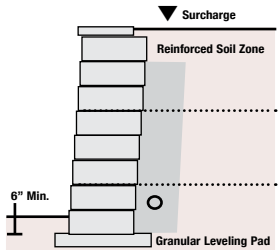

IF STAMPED ENGINEERING IS REQUIRED FOR THIS RETAINING WALL: THIS DESIGN MUST BE STAMPED HERE BY A LICENSED ENGINEER.

GEOGRID PLACEMENT

Note: Grid measurements start from the face of the wall.
• 100 psf Surcharge is light traffic i.e. car or pickup

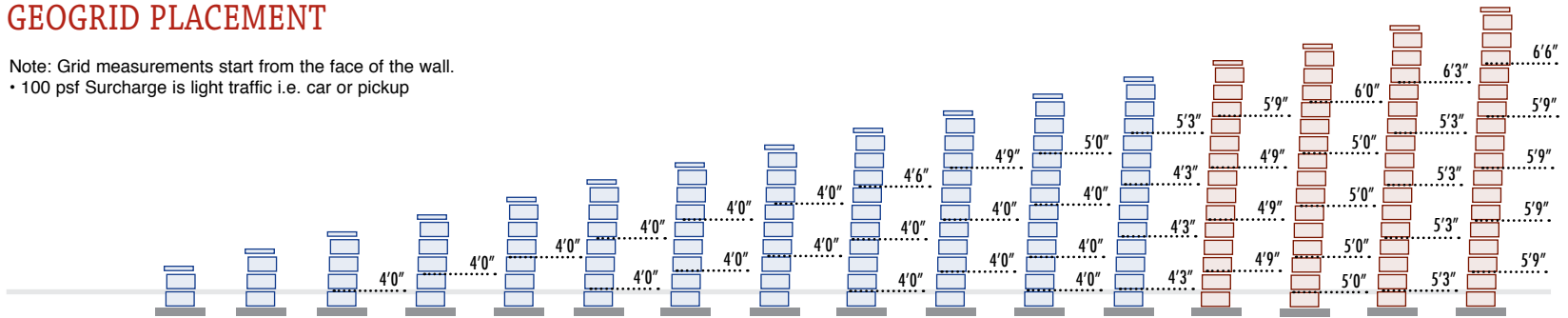

Geogrid Type	SRW Universal - or - SRW 3 Series Grid												SRW 3 Series Grid ONLY			
	0'6"	1'0"	1'6"	2'0"	2'6"	3'0"	3'6"	4'0"	4'6"	5'0"	5'6"	6'0"	6'6"	7'0"	7'6"	8'0"
Exposed Hgt wo/cap	0'6"	1'0"	1'6"	2'0"	2'6"	3'0"	3'6"	4'0"	4'6"	5'0"	5'6"	6'0"	6'6"	7'0"	7'6"	8'0"
Amount Buried	6"	6"	6"	6"	6"	6"	6"	6"	6"	6"	6"	6"	6"	6"	6"	6"
Total Hgt wo/cap	1'0"	1'5"	2'	2'5"	3'	3'5"	4'	4'5"	5'	5'5"	6'	6'5"	7'	7'5"	8'	8'5"
Grid Sq Yd per Ln Ft	0.000	0.000	0.444	0.444	0.444	0.889	0.889	1.889	1.389	1.417	1.889	2.000	2.222	2.889	3.028	3.278
Grid total depth	-	-	4'0"	4'0"	4'0"	8'0"	8'0"	8'0"	12'50"	12'75"	17'00"	18'00"	20'00"	26'00"	27'25"	29'50"
Sq Ft Block/Ln Ft	2.40	3.60	4.80	6.00	7.20	8.40	9.60	10.80	12.00	13.20	14.40	15.60	16.80	18.00	19.20	20.40
# Cap per Ln Ft	1.00	1.00	1.00	1.00	1.00	1.00	1.00	1.00	1.00	1.00	1.00	1.00	1.00	1.00	1.00	1.00

See "Material Estimating" for Adhesive estimate

Geogrid: SRW Universal 635 LTDS or SRW 3 Series 1093 LTDS • Block Dimensions: 6"(H) x 8", 10" OR 12" (W) x 10"(D) • Avg Cover: .4167 Sq.Ft.

If used without the stamped engineering, the final determination of the suitability of the contemplated use, and its manner of use, are the sole responsibility of the user, and the user expressly releases HTS, SRW, and retaining wall unit supplier of any and all liability that might arise as a result. These designs have been performed with National Concrete Masonry Association (NCMA) software and have been analyzed for the appropriate factors of safety. © 2009 Hardscape Technical Services • Maytrx® is a registered trademark of Maytrx Premier Stone System.

30 DEGREE SOIL

for walls up to 8'

Maytrx® Block • SRW Accessories



30 DEGREE SOIL for walls up to 8'

Maytrx® Block • SRW Accessories

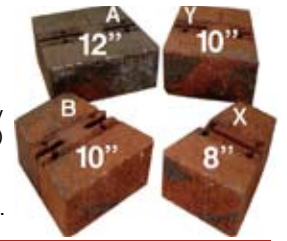

If used without the stamped engineering, the final determination of the suitability of the contemplated use, and its manner of use, are the sole responsibility of the user, and the user expressly releases HTS, SRW, and retaining wall unit supplier of any and all liability that might arise as a result. These designs have been performed with National Concrete Masonry Association (NCMA) software and have been analyzed for the appropriate factors of safety. © 2009 Hardscape Technical Services • Maytrx® is a registered trademark of Maytrx Premier Stone System.

Geogrid: SRW Universal 635 LTDS or SRW 3 Series 1093 LTDS • Block Dimensions: 6”(H) x 8”, 10” OR 12” (W) x 10”(D) • Avg Cover: .4167 Sq.Ft.

CASE C

- “CASE C” Retaining Wall:**
- Flat Ground at Top of Wall
 - Flat Ground at Bottom of Wall
 - 250 psf Surcharge on Wall

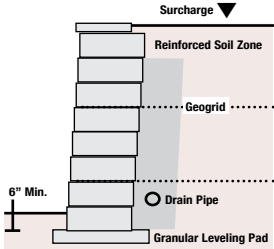

IF STAMPED ENGINEERING IS REQUIRED FOR THIS RETAINING WALL: THIS DESIGN MUST BE STAMPED HERE BY A LICENSED ENGINEER.

GEOGRID PLACEMENT

- Note: Grid measurements start from the face of the wall.
- Surcharge begins two feet behind wall facing.
 - 250 psf Surcharge is heavier traffic i.e. RV, large vehicle

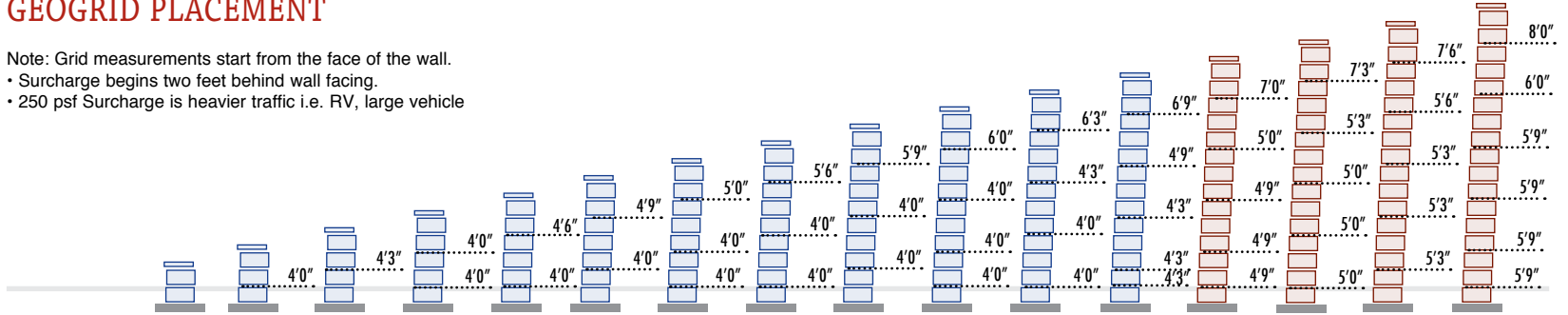

Geogrid Type	SRW Universal - or - SRW 3 Series Grid												SRW 3 Series Grid ONLY			
	0'6"	1'0"	1'6"	2'0"	2'6"	3'0"	3'6"	4'0"	4'6"	5'0"	5'6"	6'0"	6'6"	7'0"	7'6"	8'0"
Exposed Hgt wo/cap	0'6"	1'0"	1'6"	2'0"	2'6"	3'0"	3'6"	4'0"	4'6"	5'0"	5'6"	6'0"	6'6"	7'0"	7'6"	8'0"
Amount Buried	6"	6"	6"	6"	6"	6"	6"	6"	6"	6"	6"	6"	6"	6"	6"	6"
Total Hgt wo/cap	1.0'	1.5'	2'	2.5'	3'	3.5'	4'	4.5'	5'	5.5'	6'	6.5'	7'	7.5'	8'	8.5'
Grid Sq Yd per Ln Ft	0.000	0.444	0.472	0.889	0.944	0.972	1.444	1.500	1.528	2.000	2.056	2.694	2.917	3.056	3.194	4.111
Grid total depth	-	4.00	4.25	8.00	8.50	8.75	13.00	13.50	13.75	18.00	18.50	24.25	26.25	27.50	28.75	37.00
Sq Ft Block/Ln Ft	2.40	3.60	4.80	6.00	7.20	8.40	9.60	10.80	12.00	13.20	14.40	15.60	16.80	18.00	19.20	20.40
# Cap per Ln Ft	1.00	1.00	1.00	1.00	1.00	1.00	1.00	1.00	1.00	1.00	1.00	1.00	1.00	1.00	1.00	1.00

See "Material Estimating" for Adhesive estimate

CASE D

- “CASE D” Retaining Wall:**
- 4/1 Slope at Top of Wall
 - Flat Ground at Bottom of Wall
 - No Surcharge on Wall

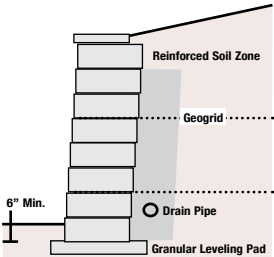

IF STAMPED ENGINEERING IS REQUIRED FOR THIS RETAINING WALL: THIS DESIGN MUST BE STAMPED HERE BY A LICENSED ENGINEER.

GEOGRID PLACEMENT

Note: Grid measurements start from the face of the wall.

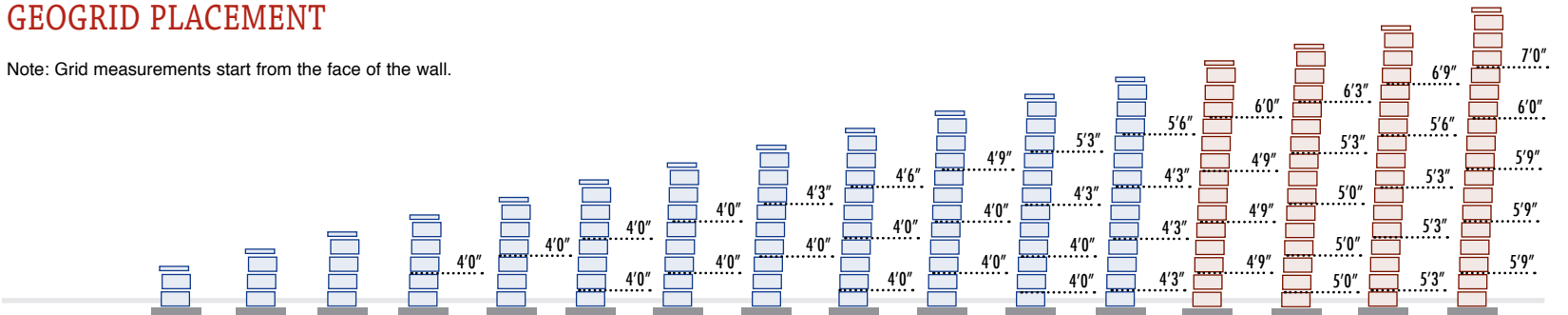

Geogrid Type	SRW Universal - or - SRW 3 Series Grid												SRW 3 Series Grid ONLY			
	0'6"	1'0"	1'6"	2'0"	2'6"	3'0"	3'6"	4'0"	4'6"	5'0"	5'6"	6'0"	6'6"	7'0"	7'6"	8'0"
Exposed Hgt wo/cap	0'6"	1'0"	1'6"	2'0"	2'6"	3'0"	3'6"	4'0"	4'6"	5'0"	5'6"	6'0"	6'6"	7'0"	7'6"	8'0"
Amount Buried	6"	6"	6"	6"	6"	6"	6"	6"	6"	6"	6"	6"	6"	6"	6"	6"
Total Hgt wo/cap	1.0'	1.5'	2'	2.5'	3'	3.5'	4'	4.5'	5'	5.5'	6'	6.5'	7'	7.5'	8'	8.5'
Grid Sq Yd per Ln Ft	0.000	0.000	0.000	0.444	0.444	0.889	0.889	0.917	1.389	1.417	1.944	2.028	2.250	2.944	3.111	3.361
Grid total depth	-	-	-	4.00	4.00	8.00	8.00	8.25	12.50	12.75	17.50	18.25	20.25	26.50	28.00	30.25
Sq Ft Block/Ln Ft	2.40	3.60	4.80	6.00	7.20	8.40	9.60	10.80	12.00	13.20	14.40	15.60	16.80	18.00	19.20	20.40
# Cap per Ln Ft	1.00	1.00	1.00	1.00	1.00	1.00	1.00	1.00	1.00	1.00	1.00	1.00	1.00	1.00	1.00	1.00

See "Material Estimating" for Adhesive estimate

CASE E

- "CASE E" Retaining Wall:**
- 2/1 Slope at Top of Wall
 - Flat Ground at Bottom of Wall
 - No Surcharge on Wall

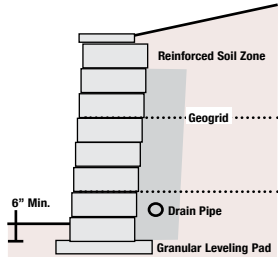

IF STAMPED ENGINEERING IS REQUIRED FOR THIS RETAINING WALL: THIS DESIGN MUST BE STAMPED HERE BY A LICENSED ENGINEER.

GEOGRID PLACEMENT

Note: Grid measurements start from the face of the wall.

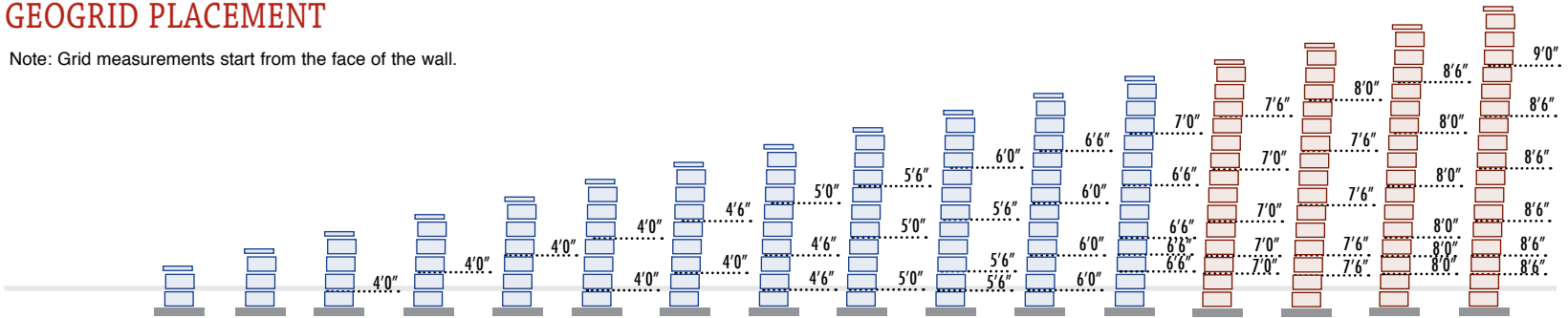

Geogrid Type	SRW Universal - or - SRW 3 Series Grid													SRW 3 Series Grid ONLY			
	0'6"	1'0"	1'6"	2'0"	2'6"	3'0"	3'6"	4'0"	4'6"	5'0"	5'6"	6'0"	6'6"	7'0"	7'6"	8'0"	
Exposed Hgt wo/cap	0'6"	1'0"	1'6"	2'0"	2'6"	3'0"	3'6"	4'0"	4'6"	5'0"	5'6"	6'0"	6'6"	7'0"	7'6"	8'0"	
Amount Buried	6"	6"	6"	6"	6"	6"	6"	6"	6"	6"	6"	6"	6"	6"	6"	6"	
Total Hgt wo/cap	1.0'	1.5'	2'	2.5'	3'	3.5'	4'	4.5'	5'	5.5'	6'	6.5'	7'	7.5'	8'	8.5'	
Grid Sq Yd per Ln Ft	0.000	0.000	0.444	0.444	0.444	0.889	0.944	1.556	1.722	2.500	2.722	3.667	3.944	4.222	5.389	5.722	
Grid total depth	-	-	4.00	4.00	4.00	8.00	8.50	14.00	15.50	22.50	24.50	33.00	35.50	38.00	48.50	51.50	
Sq Ft Block/Ln Ft	2.40	3.60	4.80	6.00	7.20	8.40	9.60	10.80	12.00	13.20	14.40	15.60	16.80	18.00	19.20	20.40	
# Cap per Ln Ft	1.00	1.00	1.00	1.00	1.00	1.00	1.00	1.00	1.00	1.00	1.00	1.00	1.00	1.00	1.00	1.00	

See "Material Estimating" for Adhesive estimate

CASE F

- "CASE F" Retaining Wall:**
- Flat Ground at Top of Wall
 - 5/1 Slope at Bottom of Wall
 - No Surcharge on Wall

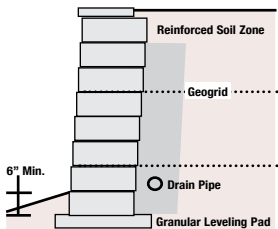

IF STAMPED ENGINEERING IS REQUIRED FOR THIS RETAINING WALL: THIS DESIGN MUST BE STAMPED HERE BY A LICENSED ENGINEER.

GEOGRID PLACEMENT

Note: Grid measurements start from the face of the wall.

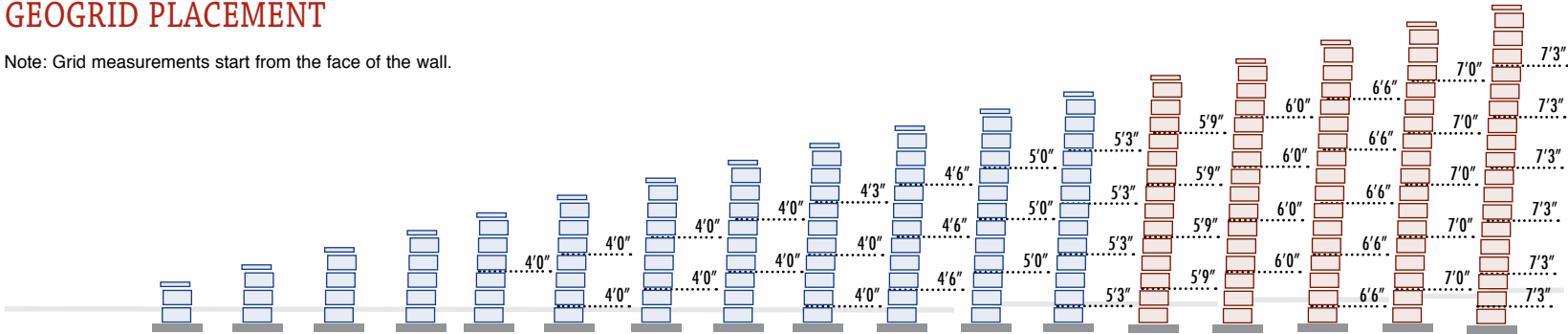

Geogrid Type	SRW Universal - or - SRW 3 Series Grid											SRW 3 Series Grid ONLY					
	0'6"	1'0"	1'6"	2'0"	2'6"	3'0"	3'6"	4'0"	4'6"	5'0"	5'5"	5'10"	6'4"	6'9"	7'3"	7'8"	8'0"
Exposed Hgt wo/cap	0'6"	1'0"	1'6"	2'0"	2'6"	3'0"	3'6"	4'0"	4'6"	5'0"	5'5"	5'10"	6'4"	6'9"	7'3"	7'8"	8'0"
Amount Buried	6"	6"	6"	6"	6"	6"	6"	6"	6"	6"	7"	8"	8"	9"	9"	10"	1'0"
Total Hgt wo/cap	1.0'	1.5'	2'	2.5'	3'	3.5'	4'	4.5'	5'	5.5'	6'	6.5'	7'	7.5'	8'	8.5'	9'
Grid Sq Yd per Ln Ft	0.000	0.000	0.000	0.000	0.444	0.889	0.889	0.889	1.361	1.500	1.667	2.333	2.556	2.667	3.611	3.889	4.833
Grid total depth	-	-	-	-	4.00	8.00	8.00	8.00	12.25	13.50	15.00	21.00	23.00	24.00	32.50	35.00	43.50
Sq Ft Block/Ln Ft	2.40	3.60	4.80	6.00	7.20	8.40	9.60	10.80	12.00	13.20	14.40	15.60	16.80	18.00	19.20	20.40	21.60
# Cap per Ln Ft	1.00	1.00	1.00	1.00	1.00	1.00	1.00	1.00	1.00	1.00	1.00	1.00	1.00	1.00	1.00	1.00	1.00

See "Material Estimating" for Adhesive estimate

Geogrid: SRW Universal 635 LTDS or SRW 3 Series 1093 LTDS • Block Dimensions: 6"(H) x 8", 10" OR 12" (W) x 10"(D) • Avg Cover: .4167 Sq.Ft.

If used without the stamped engineering, the final determination of the suitability of the contemplated use, and its manner of use, are the sole responsibility of the user, and the user expressly releases HTS, SRW, and retaining wall unit supplier of any and all liability that might arise as a result. These designs have been performed with National Concrete Masonry Association (NCMA) software and have been analyzed for the appropriate factors of safety. © 2009 Hardscape Technical Services • Maytrx® is a registered trademark of Maytrx Premier Stone System.



30 DEGREE SOIL for walls up to 8'

Maytrx® Block • SRW Accessories

30 DEGREE SOIL for walls up to 8'

Maytrx® Block • SRW Accessories

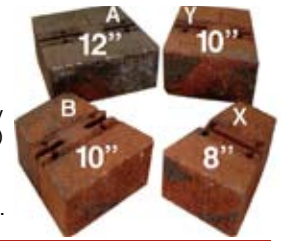

If used without the stamped engineering, the final determination of the suitability of the contemplated use, and its manner of use, are the sole responsibility of the user, and the user expressly releases HTS, SRW, and retaining wall unit supplier of any and all liability that might arise as a result. These designs have been performed with National Concrete Masonry Association (NCMA) software and have been analyzed for the appropriate factors of safety. © 2009 Hardscape Technical Services • Maytrx® is a registered trademark of Maytrx Premier Stone System.

Geogrid: SRW Universal 635 LTDS or SRW 3 Series 1093 LTDS • Block Dimensions: 6"(H) x 8", 10" OR 12" (W) x 10"(D) • Avg Cover: .4167 Sq.Ft.

CASE G

- "CASE G" Retaining Wall:**
- Flat Ground at Top of Wall
 - 5/1 Slope at Bottom of Wall
 - 100 psf Surcharge on Wall

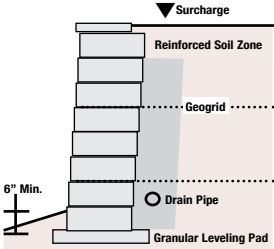

IF STAMPED ENGINEERING IS REQUIRED FOR THIS RETAINING WALL: THIS DESIGN MUST BE STAMPED HERE BY A LICENSED ENGINEER.

GEOGRID PLACEMENT

Note: Grid measurements start from the face of the wall.
• 100 psf Surcharge is light traffic i.e. car or pickup

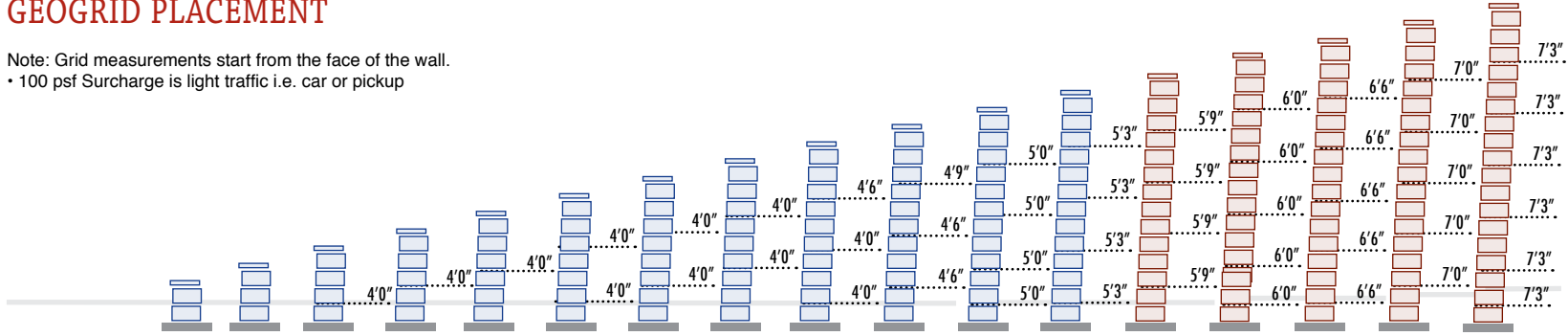

Geogrid Type	SRW Universal - or - SRW 3 Series Grid												SRW 3 Series Grid ONLY				
	0'6"	1'0"	1'6"	2'0"	2'6"	3'0"	3'6"	4'0"	4'6"	5'0"	5'5"	5'10"	6'4"	6'9"	7'3"	7'8"	8'0"
Exposed Hgt wo/cap	0'6"	1'0"	1'6"	2'0"	2'6"	3'0"	3'6"	4'0"	4'6"	5'0"	5'5"	5'10"	6'4"	6'9"	7'3"	7'8"	8'0"
Amount Buried	6"	6"	6"	6"	6"	6"	6"	6"	6"	6"	7"	8"	8"	9"	9"	10"	1'0"
Total Hgt wo/cap	1.0'	1.5'	2'	2.5'	3'	3.5'	4'	4.5'	5'	5.5'	6'	6.5'	7'	7.5'	8'	8.5'	9'
Grid Sq Yd per Ln Ft	0.000	0.000	0.444	0.444	0.444	0.889	0.889	0.889	1.389	1.528	2.222	2.333	2.556	3.333	3.611	3.889	4.833
Grid total depth	-	-	4.00	4.00	4.00	8.00	8.00	8.00	12.50	13.75	20.00	21.00	23.00	30.00	32.50	35.00	43.50
Sq Ft Block/Ln Ft	2.40	3.60	4.80	6.00	7.20	8.40	9.60	10.80	12.00	13.20	14.40	15.60	16.80	18.00	19.20	20.10	21.60
# Cap per Ln Ft	1.00	1.00	1.00	1.00	1.00	1.00	1.00	1.00	1.00	1.00	1.00	1.00	1.00	1.00	1.00	1.00	1.00

See "Material Estimating" for Adhesive estimate

CASE H

- "CASE H" Retaining Wall:**
- Flat Ground at Top of Wall
 - 5/1 Slope at Bottom of Wall
 - 250 psf Surcharge on Wall

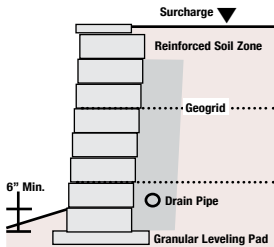

IF STAMPED ENGINEERING IS REQUIRED FOR THIS RETAINING WALL: THIS DESIGN MUST BE STAMPED HERE BY A LICENSED ENGINEER.

GEOGRID PLACEMENT

Note: Grid measurements start from the face of the wall.
• Surcharge begins two feet behind wall facing.
• 250 psf Surcharge is heavier traffic i.e. RV, large vehicle

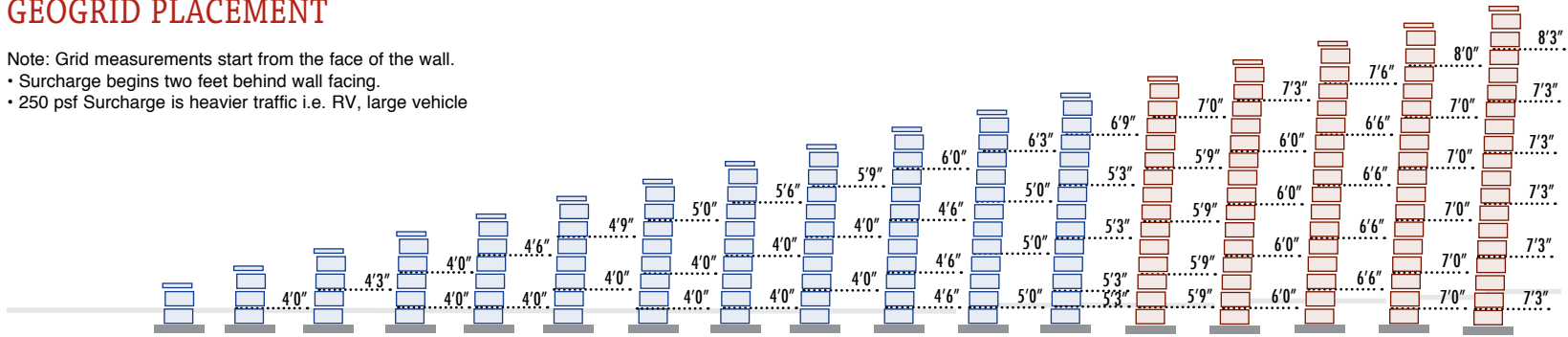

Geogrid Type	SRW Universal - or - SRW 3 Series Grid												SRW 3 Series Grid ONLY				
	0'6"	1'0"	1'6"	2'0"	2'6"	3'0"	3'6"	4'0"	4'6"	5'0"	5'5"	5'10"	6'4"	6'9"	7'3"	7'8"	8'0"
Exposed Hgt wo/cap	0'6"	1'0"	1'6"	2'0"	2'6"	3'0"	3'6"	4'0"	4'6"	5'0"	5'5"	5'10"	6'4"	6'9"	7'3"	7'8"	8'0"
Amount Buried	6"	6"	6"	6"	6"	6"	6"	6"	6"	6"	7"	8"	8"	9"	9"	10"	1'0"
Total Hgt wo/cap	1.0'	1.5'	2'	2.5'	3'	3.5'	4'	4.5'	5'	5.5'	6'	6.5'	7'	7.5'	8'	8.5'	9'
Grid Sq Yd per Ln Ft	0.000	0.444	0.472	0.889	0.944	0.972	1.444	1.500	1.528	2.167	2.361	3.083	3.333	3.472	3.722	4.778	4.944
Grid total depth	-	4.00	4.25	8.00	8.50	8.75	13.00	13.50	13.75	19.50	21.25	27.75	30.00	31.25	33.50	43.00	44.50
Sq Ft Block/Ln Ft	2.40	3.60	4.80	6.00	7.20	8.40	9.60	10.80	12.00	13.20	14.40	15.60	16.80	18.00	19.20	20.40	21.60
# Cap per Ln Ft	1.00	1.00	1.00	1.00	1.00	1.00	1.00	1.00	1.00	1.00	1.00	1.00	1.00	1.00	1.00	1.00	1.00

See "Material Estimating" for Adhesive estimate

CASE I

- "CASE I" Retaining Wall:**
- Flat Ground at Top of Wall
 - 4/1 Slope at Bottom of Wall
 - No Surcharge on Wall

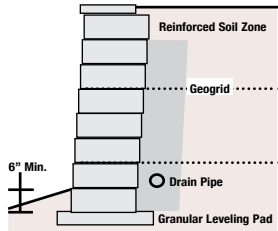

IF STAMPED ENGINEERING IS REQUIRED FOR THIS RETAINING WALL: THIS DESIGN MUST BE STAMPED HERE BY A LICENSED ENGINEER.

GEOGRID PLACEMENT

Note: Grid measurements start from the face of the wall.

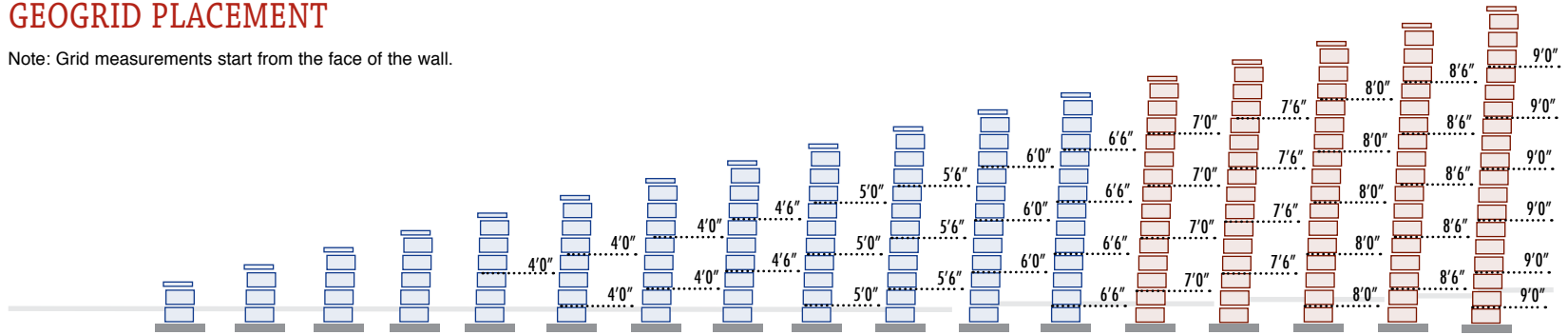

Geogrid Type	SRW Universal - or - SRW 3 Series Grid											SRW 3 Series Grid ONLY					
Exposed Hgt wo/cap	0'6"	1'0"	1'6"	2'0"	2'6"	3'0"	3'6"	4'0"	4'6"	5'0"	5'5"	5'10"	6'4"	6'9"	7'3"	7'8"	8'0"
Amount Buried	6"	6"	6"	6"	6"	6"	6"	6"	6"	6"	7"	8"	8"	9"	9"	10"	10"
Total Hgt wo/cap	1.0'	1.5'	2'	2.5'	3'	3.5'	4'	4.5'	5'	5.5'	6'	6.5'	7'	7.5'	8'	8.5'	9'
Grid Sq Yd per Ln Ft	0.000	0.000	0.000	0.000	0.444	0.889	0.889	1.000	1.667	1.833	2.000	2.889	3.111	3.333	4.444	4.722	6.000
Grid total depth	-	-	-	-	4.00	8.00	8.00	9.00	15.00	16.50	18.00	26.00	28.00	30.00	40.00	42.50	54.00
Sq Ft Block/Ln Ft	2.40	3.60	4.80	6.00	7.20	8.40	9.60	10.80	12.00	13.20	14.40	15.60	16.80	18.00	19.20	20.40	21.60
# Cap per Ln Ft	1.00	1.00	1.00	1.00	1.00	1.00	1.00	1.00	1.00	1.00	1.00	1.00	1.00	1.00	1.00	1.00	1.00

See "Material Estimating" for Adhesive estimate

CASE J

- "CASE J" Retaining Wall:**
- Flat Ground at Top of Wall
 - 4/1 Slope at Bottom of Wall
 - 100 psf Surcharge on Wall

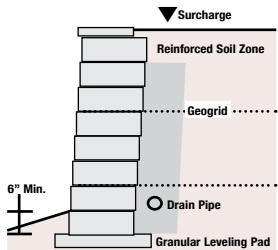

IF STAMPED ENGINEERING IS REQUIRED FOR THIS RETAINING WALL: THIS DESIGN MUST BE STAMPED HERE BY A LICENSED ENGINEER.

GEOGRID PLACEMENT

Note: Grid measurements start from the face of the wall.

- 100 psf Surcharge is light traffic i.e. car or pickup

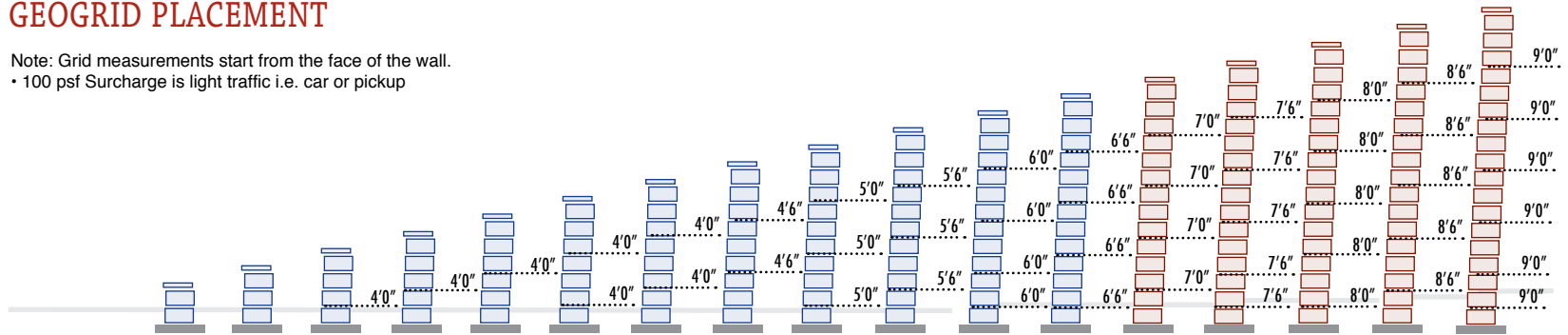

Geogrid Type	SRW Universal - or - SRW 3 Series Grid											SRW 3 Series Grid ONLY					
Exposed Hgt wo/cap	0'6"	1'0"	1'6"	2'0"	2'6"	3'0"	3'6"	4'0"	4'6"	5'0"	5'5"	5'10"	6'4"	6'9"	7'3"	7'8"	8'0"
Amount Buried	6"	6"	6"	6"	6"	6"	6"	6"	6"	6"	7"	8"	8"	9"	9"	10"	10"
Total Hgt wo/cap	1.0'	1.5'	2'	2.5'	3'	3.5'	4'	4.5'	5'	5.5'	6'	6.5'	7'	7.5'	8'	8.5'	9'
Grid Sq Yd per Ln Ft	0.000	0.000	0.444	0.444	0.444	0.889	0.889	1.000	1.667	1.833	2.667	2.889	3.111	4.167	4.444	4.722	6.000
Grid total depth	-	-	4.00	4.00	4.00	8.00	8.00	9.00	15.00	16.50	24.00	26.00	28.00	37.50	40.00	42.50	54.00
Sq Ft Block/Ln Ft	2.40	3.60	4.80	6.00	7.20	8.40	9.60	10.80	12.00	13.20	14.40	15.60	16.80	18.00	19.20	20.40	21.60
# Cap per Ln Ft	1.00	1.00	1.00	1.00	1.00	1.00	1.00	1.00	1.00	1.00	1.00	1.00	1.00	1.00	1.00	1.00	1.00

See "Material Estimating" for Adhesive estimate

Geogrid: SRW Universal 635 LTDS or SRW 3 Series 1093 LTDS • Block Dimensions: 6"(H) x 8", 10" OR 12" (W) x 10"(D) • Avg Cover: .4167 Sq.Ft.

If used without the stamped engineering, the final determination of the suitability of the contemplated use, and its manner of use, are the sole responsibility of the user, and the user expressly releases HTS, SRW, and retaining wall unit supplier of any and all liability that might arise as a result. These designs have been performed with National Concrete Masonry Association (NCMA) software and have been analyzed for the appropriate factors of safety. © 2009 Hardscape Technical Services • Maytrx® is a registered trademark of Maytrx Premier Stone System.

30 DEGREE SOIL for walls up to 8'

Maytrx® Block • SRW Accessories

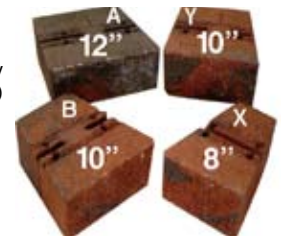

30 DEGREE SOIL for walls up to 8'

Maytrx® Block • SRW Accessories

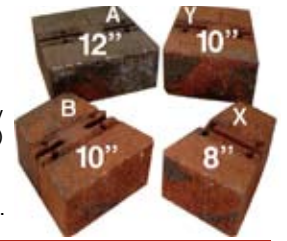

If used without the stamped engineering, the final determination of the suitability of the contemplated use, and its manner of use, are the sole responsibility of the user, and the user expressly releases HTS, SRW, and retaining wall unit supplier of any and all liability that might arise as a result. These designs have been performed with National Concrete Masonry Association (NCMA) software and have been analyzed for the appropriate factors of safety. © 2009 Hardscape Technical Services • Maytrx® is a registered trademark of Maytrx Premier Stone System.

Geogrid: SRW Universal 635 LTDS or SRW 3 Series 1093 LTDS • Block Dimensions: 6"(H) x 8", 10" OR 12" (W) x 10"(D) • Avg Cover: .4167 Sq.Ft.

CASE K

- "CASE K" Retaining Wall:**
- Flat Ground at Top of Wall
 - 4/1 Slope at Bottom of Wall
 - 250 psf Surcharge on Wall

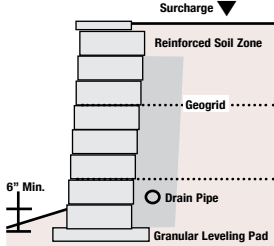

IF STAMPED ENGINEERING IS REQUIRED FOR THIS RETAINING WALL: THIS DESIGN MUST BE STAMPED HERE BY A LICENSED ENGINEER.

GEOGRID PLACEMENT

- Note: Grid measurements start from the face of the wall.
- Surcharge begins two feet behind wall facing.
 - 250 psf Surcharge is heavier traffic i.e. RV, large vehicle

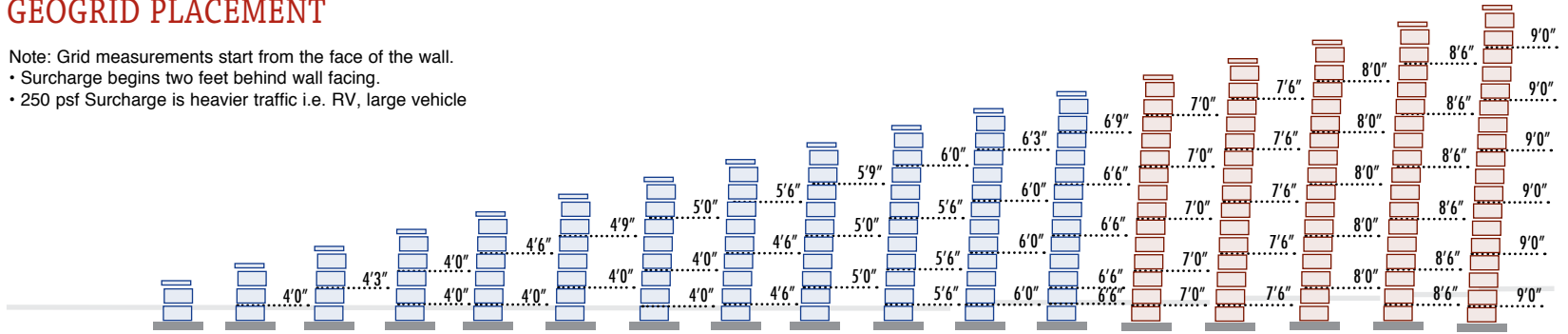

Geogrid Type	SRW Universal - or - SRW 3 Series Grid												SRW 3 Series Grid ONLY					
	0'6"	1'0"	1'6"	2'0"	2'6"	3'0"	3'6"	4'0"	4'6"	5'0"	5'5"	5'10"	6'4"	6'9"	7'3"	7'8"	8'0"	
Exposed Hgt wo/cap	6"	6"	6"	6"	6"	6"	6"	6"	6"	6"	7"	8"	8"	9"	9"	10"	10"	1'0"
Amount Buried	1.0'	1.5'	2'	2.5'	3'	3.5'	4'	4.5'	5'	5.5'	6'	6.5'	7'	7.5'	8'	8.5'	9'	9'
Total Hgt wo/cap	0.000	0.444	0.472	0.889	0.944	0.972	1.444	1.611	1.750	2.500	2.694	3.639	3.889	4.167	4.444	5.667	6.000	6.000
Grid Sq Yd per Ln Ft	-	4.00	4.25	8.00	8.50	8.75	13.00	14.50	15.75	22.50	24.25	32.75	35.00	37.50	40.00	51.00	54.00	54.00
Grid total depth	2.40	3.60	4.80	6.00	7.20	8.40	9.60	10.80	12.00	13.20	14.40	15.60	16.80	18.00	19.20	20.40	21.60	21.60
Sq Ft Block/Ln Ft	1.00	1.00	1.00	1.00	1.00	1.00	1.00	1.00	1.00	1.00	1.00	1.00	1.00	1.00	1.00	1.00	1.00	1.00
# Cap per Ln Ft																		

See "Material Estimating" for Adhesive estimate

CASE L

- "CASE L" Retaining Wall:**
- Flat Ground at Top of Wall
 - 3/1 Slope at Bottom of Wall
 - No Surcharge on Wall

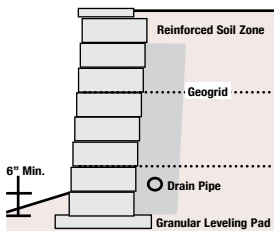

IF STAMPED ENGINEERING IS REQUIRED FOR THIS RETAINING WALL: THIS DESIGN MUST BE STAMPED HERE BY A LICENSED ENGINEER.

GEOGRID PLACEMENT

Note: Grid measurements start from the face of the wall.

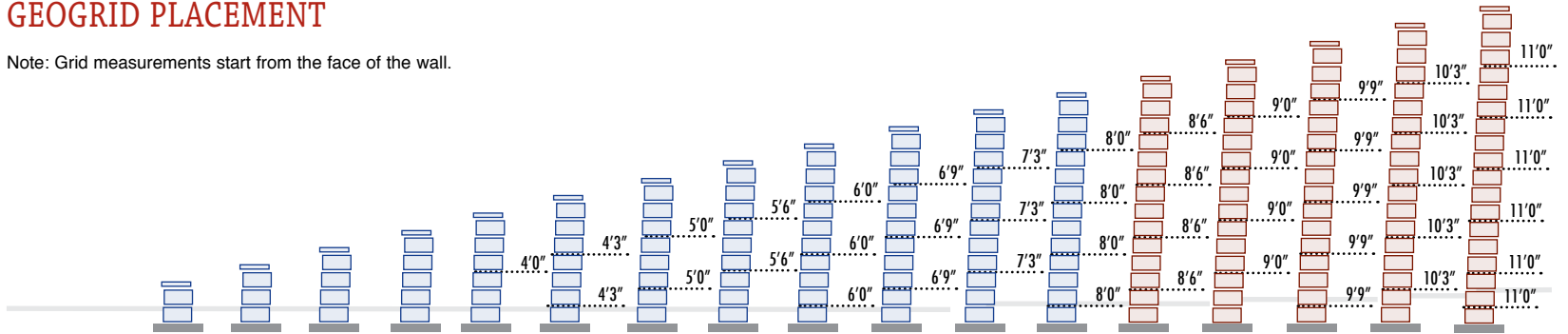

Geogrid Type	SRW Universal - or - SRW 3 Series Grid												SRW 3 Series Grid ONLY					
	0'6"	1'0"	1'6"	2'0"	2'6"	3'0"	3'6"	4'0"	4'6"	5'0"	5'5"	5'10"	6'4"	6'9"	7'3"	7'8"	8'0"	
Exposed Hgt wo/cap	6"	6"	6"	6"	6"	6"	6"	6"	6"	6"	7"	8"	8"	9"	9"	10"	10"	1'0"
Amount Buried	1.0'	1.5'	2'	2.5'	3'	3.5'	4'	4.5'	5'	5.5'	6'	6.5'	7'	7.5'	8'	8.5'	9'	9'
Total Hgt wo/cap	0.000	0.000	0.000	0.000	0.444	0.944	1.111	1.222	2.000	2.250	2.417	3.556	3.778	4.000	5.417	5.694	7.333	7.333
Grid Sq Yd per Ln Ft	-	-	-	-	4.00	8.50	10.00	11.00	18.00	20.25	21.75	32.00	34.00	36.00	48.75	51.25	66.00	66.00
Grid total depth	2.40	3.60	4.80	6.00	7.20	8.40	9.60	10.80	12.00	13.20	14.40	15.60	16.80	18.00	19.20	20.40	21.60	21.60
Sq Ft Block/Ln Ft	1.00	1.00	1.00	1.00	1.00	1.00	1.00	1.00	1.00	1.00	1.00	1.00	1.00	1.00	1.00	1.00	1.00	1.00
# Cap per Ln Ft																		

See "Material Estimating" for Adhesive estimate

CASE M

- "CASE M" Retaining Wall:**
- Flat Ground at Top of Wall
 - 3/1 Slope at Bottom of Wall
 - 100 psf Surcharge on Wall

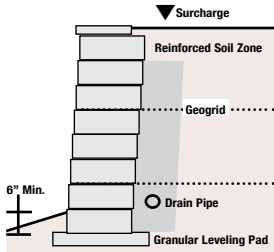

IF STAMPED ENGINEERING IS REQUIRED FOR THIS RETAINING WALL: THIS DESIGN MUST BE STAMPED HERE BY A LICENSED ENGINEER.

GEOGRID PLACEMENT

Note: Grid measurements start from the face of the wall.
 • 100 psf Surcharge is light traffic i.e. car or pickup

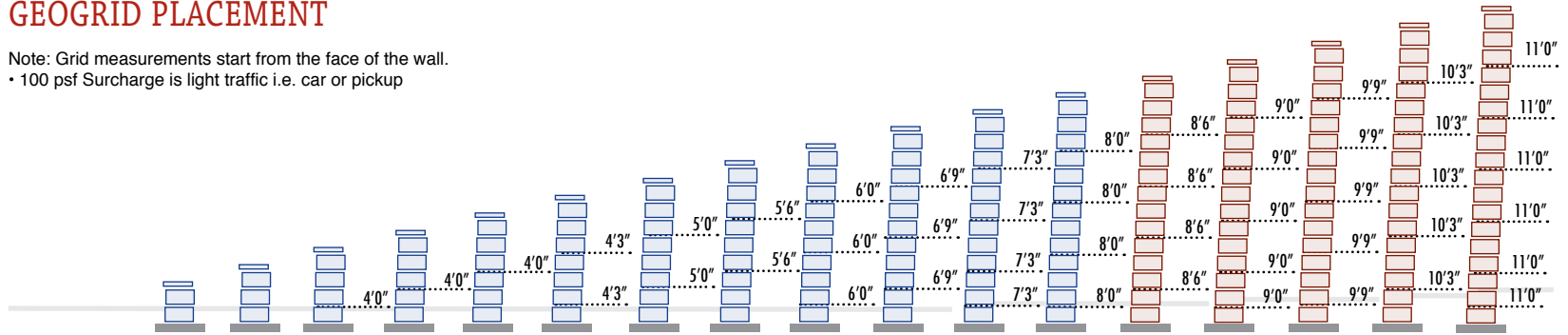

Geogrid Type	SRW Universal - or - SRW 3 Series Grid												SRW 3 Series Grid ONLY				
	0'6"	1'0"	1'6"	2'0"	2'6"	3'0"	3'6"	4'0"	4'6"	5'0"	5'5"	5'10"	6'4"	6'9"	7'3"	7'8"	8'0"
Exposed Hgt wo/cap	0'6"	1'0"	1'6"	2'0"	2'6"	3'0"	3'6"	4'0"	4'6"	5'0"	5'5"	5'10"	6'4"	6'9"	7'3"	7'8"	8'0"
Amount Buried	6"	6"	6"	6"	6"	6"	6"	6"	6"	6"	7"	8"	8"	9"	9"	10"	1'0"
Total Hgt wo/cap	1.0'	1.5'	2'	2.5'	3'	3.5'	4'	4.5'	5'	5.5'	6'	6.5'	7'	7.5'	8'	8.5'	9'
Grid Sq Yd per Ln Ft	0.000	0.000	0.444	0.444	0.444	0.944	1.111	1.222	2.000	2.250	3.222	3.556	3.778	5.000	5.417	5.694	7.333
Grid total depth	-	-	4.00	4.00	4.00	8.50	10.00	11.00	18.00	20.25	29.00	32.00	34.00	45.00	48.75	51.25	66.00
Sq Ft Block/Ln Ft	2.40	3.60	4.80	6.00	7.20	8.40	9.60	10.80	12.00	13.20	14.40	15.60	16.80	18.00	19.20	20.40	21.60
# Cap per Ln Ft	1.00	1.00	1.00	1.00	1.00	1.00	1.00	1.00	1.00	1.00	1.00	1.00	1.00	1.00	1.00	1.00	1.00

See "Material Estimating" for Adhesive estimate

CASE N

- "CASE N" Retaining Wall:**
- Flat Ground at Top of Wall
 - 3/1 Slope at Bottom of Wall
 - 250 psf Surcharge on Wall

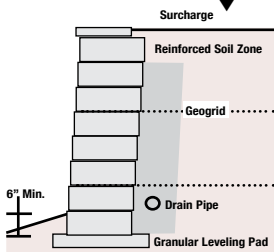

IF STAMPED ENGINEERING IS REQUIRED FOR THIS RETAINING WALL: THIS DESIGN MUST BE STAMPED HERE BY A LICENSED ENGINEER.

GEOGRID PLACEMENT

Note: Grid measurements start from the face of the wall.
 • Surcharge begins two feet behind wall facing.
 • 250 psf Surcharge is heavier traffic i.e. RV, large vehicle

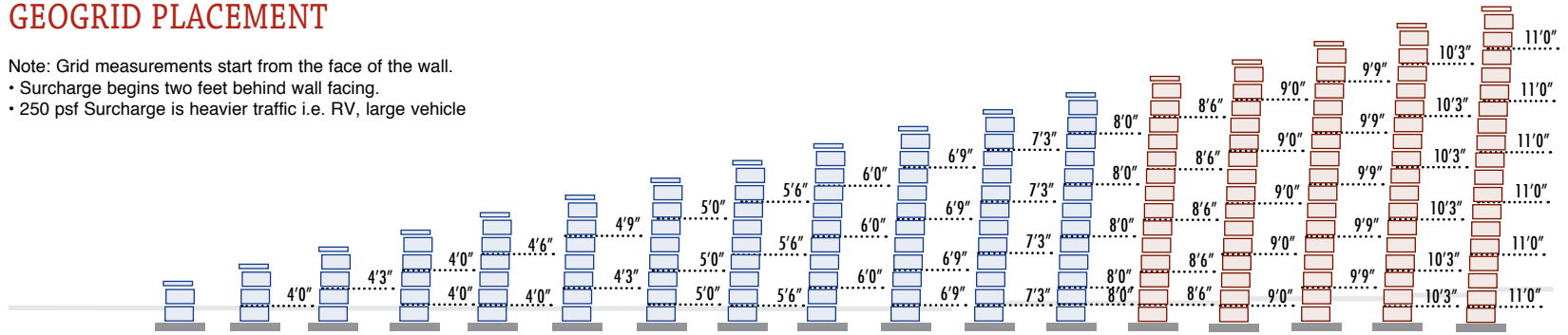

Geogrid Type	SRW Universal - or - SRW 3 Series Grid												SRW 3 Series Grid ONLY				
	0'6"	1'0"	1'6"	2'0"	2'6"	3'0"	3'6"	4'0"	4'6"	5'0"	5'5"	5'10"	6'4"	6'9"	7'3"	7'8"	8'0"
Exposed Hgt wo/cap	0'6"	1'0"	1'6"	2'0"	2'6"	3'0"	3'6"	4'0"	4'6"	5'0"	5'5"	5'10"	6'4"	6'9"	7'3"	7'8"	8'0"
Amount Buried	6"	6"	6"	6"	6"	6"	6"	6"	6"	6"	7"	8"	8"	9"	9"	10"	1'0"
Total Hgt wo/cap	1.0'	1.5'	2'	2.5'	3'	3.5'	4'	4.5'	5'	5.5'	6'	6.5'	7'	7.5'	8'	8.5'	9'
Grid Sq Yd per Ln Ft	0.000	0.444	0.472	0.889	0.944	1.000	1.667	1.833	2.000	3.000	3.222	4.444	4.722	5.000	5.417	6.833	7.333
Grid total depth	-	4.00	4.25	8.00	8.50	9.00	15.00	16.50	18.00	27.00	29.00	40.00	42.50	45.00	48.75	61.50	66.00
Sq Ft Block/Ln Ft	2.40	3.60	4.80	6.00	7.20	8.40	9.60	10.80	12.00	13.20	14.40	15.60	16.80	18.00	19.20	20.40	21.60
# Cap per Ln Ft	1.00	1.00	1.00	1.00	1.00	1.00	1.00	1.00	1.00	1.00	1.00	1.00	1.00	1.00	1.00	1.00	1.00

See "Material Estimating" for Adhesive estimate

Geogrid: SRW Universal 635 LTDS or SRW 3 Series 1093 LTDS • Block Dimensions: 6"(H) x 8", 10" OR 12" (W) x 10"(D) • Avg Cover: .4167 Sq.Ft.

If used without the stamped engineering, the final determination of the suitability of the contemplated use, and its manner of use, are the sole responsibility of the user, and the user expressly releases HTS, SRW, and retaining wall unit supplier of any and all liability that might arise as a result. These designs have been performed with National Concrete Masonry Association (NCMA) software and have been analyzed for the appropriate factors of safety. © 2009 Hardscape Technical Services • Maytrx® is a registered trademark of Maytrx Premier Stone System.

30 DEGREE SOIL for walls up to 8'

Maytrx® Block • SRW Accessories

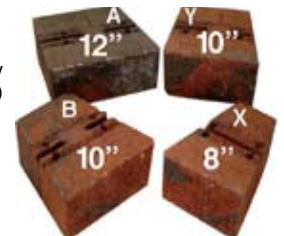

30 DEGREE SOIL for walls up to 8'

Maytrx® Block • SRW Accessories

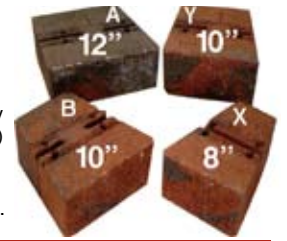

If used without the stamped engineering, the final determination of the suitability of the contemplated use, and its manner of use, are the sole responsibility of the user, and the user expressly releases HTS, SRW, and retaining wall unit supplier of any and all liability that might arise as a result. These designs have been performed with National Concrete Masonry Association (NCMA) software and have been analyzed for the appropriate factors of safety. © 2009 Hardscape Technical Services • Maytrx® is a registered trademark of Maytrx Premier Stone System.

Geogrid: SRW Universal 635 LTDS or SRW 3 Series 1093 LTDS • Block Dimensions: 6"(H) x 8", 10" OR 12" (W) x 10"(D) • Avg Cover: .4167 Sq.Ft.

CASE O

- "CASE O" Retaining Wall:**
- Flat Ground at Top of Wall
 - 2.5/1 Slope at Bottom of Wall
 - No Surcharge on Wall

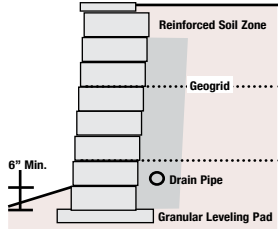

IF STAMPED ENGINEERING IS REQUIRED FOR THIS RETAINING WALL: THIS DESIGN MUST BE STAMPED HERE BY A LICENSED ENGINEER.

GEOGRID PLACEMENT

Note: Grid measurements start from the face of the wall.

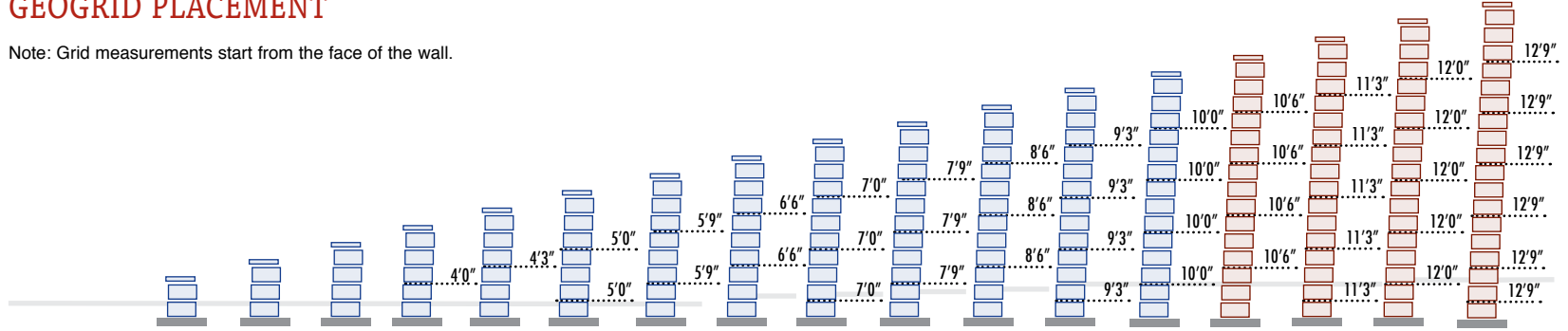

Geogrid Type	SRW Universal - or - SRW 3 Series Grid														SRW 3 Series Grid ONLY			
	0'6"	1'0"	1'6"	2'0"	2'6"	3'0"	3'6"	3'11"	4'4"	4'9"	5'2"	5'7"	6'0"	6'6"	6'11"	7'4"	7'9"	
Exposed Hgt wo/cap	0'6"	1'0"	1'6"	2'0"	2'6"	3'0"	3'6"	3'11"	4'4"	4'9"	5'2"	5'7"	6'0"	6'6"	6'11"	7'4"	7'9"	
Amount Buried	6"	6"	6"	6"	6"	6"	6"	7"	8"	9"	10"	11"	1'0"	1'0"	1'1"	1'2"	1'3"	
Total Hgt wo/cap	1.0'	1.5'	2'	2.5'	3'	3.5'	4'	4.5'	5'	5.5'	6'	6.5'	7'	7.5'	8'	8.5'	9'	
Grid Sq Yd per Ln Ft	0.000	0.000	0.000	0.444	0.472	1.111	1.278	1.444	2.333	2.583	2.833	4.111	4.444	4.667	6.250	6.667	8.500	
Grid total depth	-	-	-	4.00	4.25	10.00	11.50	13.00	21.00	23.25	25.50	37.00	40.00	42.00	56.25	60.00	76.50	
Sq Ft Block/Ln Ft	2.40	3.60	4.80	6.00	7.20	8.40	9.60	10.80	12.00	13.20	14.40	15.60	16.80	18.00	19.20	20.40	21.60	
# Cap per Ln Ft	1.00	1.00	1.00	1.00	1.00	1.00	1.00	1.00	1.00	1.00	1.00	1.00	1.00	1.00	1.00	1.00	1.00	

See "Material Estimating" for Adhesive estimate

CASE P

- "CASE P" Retaining Wall:**
- Flat Ground at Top of Wall
 - 2.5/1 Slope at Bottom of Wall
 - 100 psf Surcharge on Wall

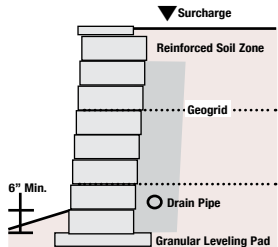

IF STAMPED ENGINEERING IS REQUIRED FOR THIS RETAINING WALL: THIS DESIGN MUST BE STAMPED HERE BY A LICENSED ENGINEER.

GEOGRID PLACEMENT

Note: Grid measurements start from the face of the wall.
• 100 psf Surcharge is light traffic i.e. car or pickup

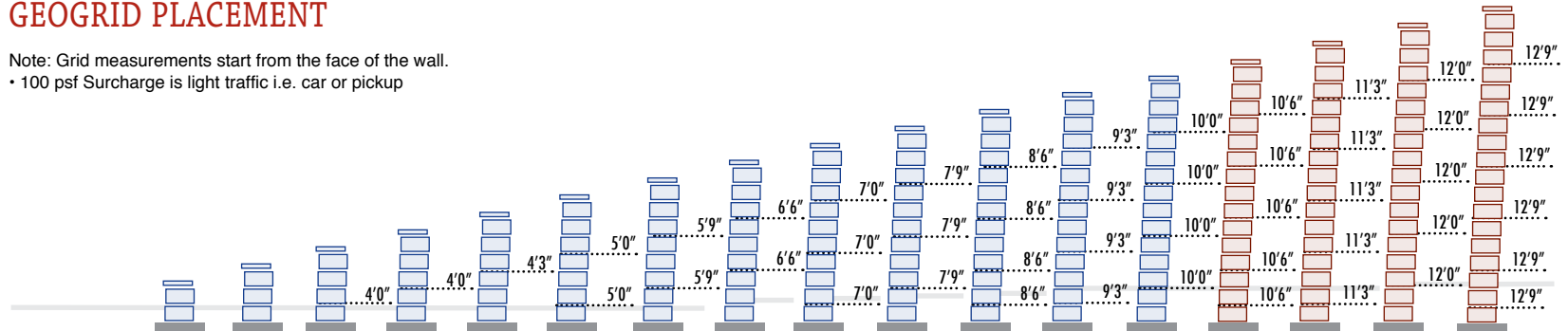

Geogrid Type	SRW Universal - or - SRW 3 Series Grid														SRW 3 Series Grid ONLY			
	0'6"	1'0"	1'6"	2'0"	2'6"	3'0"	3'6"	3'11"	4'4"	4'9"	5'2"	5'7"	6'0"	6'6"	6'11"	7'4"	7'9"	
Exposed Hgt wo/cap	0'6"	1'0"	1'6"	2'0"	2'6"	3'0"	3'6"	3'11"	4'4"	4'9"	5'2"	5'7"	6'0"	6'6"	6'11"	7'4"	7'9"	
Amount Buried	6"	6"	6"	6"	6"	6"	6"	7"	8"	9"	10"	11"	1'0"	1'0"	1'1"	1'2"	1'3"	
Total Hgt wo/cap	1.0'	1.5'	2'	2.5'	3'	3.5'	4'	4.5'	5'	5.5'	6'	6.5'	7'	7.5'	8'	8.5'	9'	
Grid Sq Yd per Ln Ft	0.000	0.000	0.444	0.444	0.472	1.111	1.278	1.444	2.333	2.583	3.778	4.111	4.444	5.833	6.250	6.667	8.500	
Grid total depth	-	-	4.00	4.00	4.25	10.00	11.50	13.00	21.00	23.25	34.00	37.00	40.00	52.50	56.25	60.00	76.50	
Sq Ft Block/Ln Ft	2.40	3.60	4.80	6.00	7.20	8.40	9.60	10.80	12.00	13.20	14.40	15.60	16.80	18.00	19.20	20.40	21.60	
# Cap per Ln Ft	1.00	1.00	1.00	1.00	1.00	1.00	1.00	1.00	1.00	1.00	1.00	1.00	1.00	1.00	1.00	1.00	1.00	

See "Material Estimating" for Adhesive estimate

CASE Q

- "CASE Q" Retaining Wall:**
- Flat Ground at Top of Wall
 - 2.5/1 Slope at Bottom of Wall
 - 250 psf Surcharge on Wall

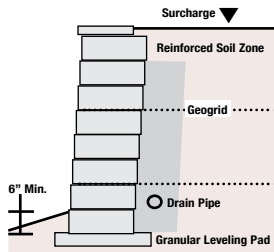

IF STAMPED ENGINEERING IS REQUIRED FOR THIS RETAINING WALL: THIS DESIGN MUST BE STAMPED HERE BY A LICENSED ENGINEER.

GEOGRID PLACEMENT

- Note: Grid measurements start from the face of the wall.
- Surcharge begins two feet behind wall facing.
 - 250 psf Surcharge is heavier traffic i.e. RV, large vehicle

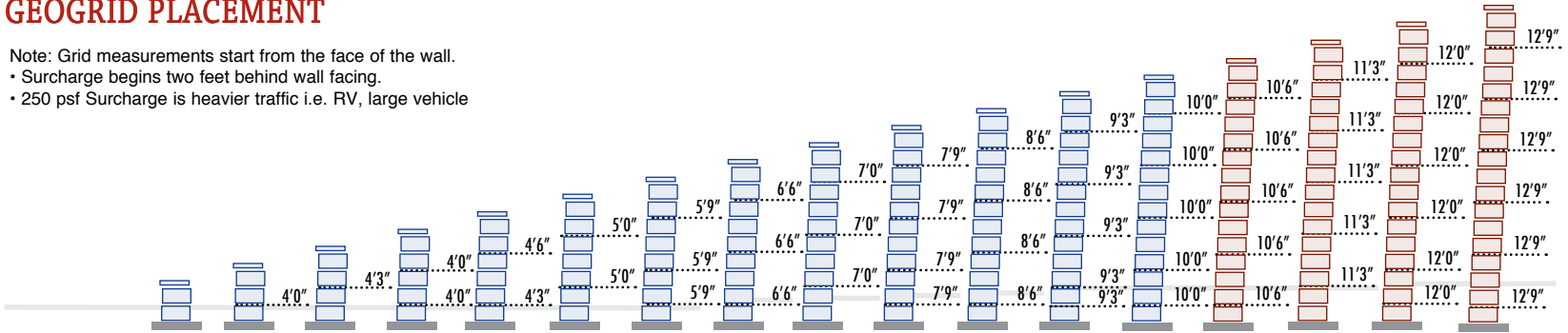

Geogrid Type	SRW Universal - or - SRW 3 Series Grid												SRW 3 Series Grid ONLY				
	0'6"	1'0"	1'6"	2'0"	2'6"	3'0"	3'6"	3'11"	4'4"	4'9"	5'2"	5'7"	6'0"	6'6"	6'11"	7'4"	7'9"
Exposed Hgt wo/cap	6"	6"	6"	6"	6"	6"	6"	7"	8"	9"	10"	11"	1'0"	1'0"	1'1"	1'2"	1'2"
Amount Buried	6"	6"	6"	6"	6"	6"	6"	7"	8"	9"	10"	11"	1'0"	1'0"	1'1"	1'2"	1'2"
Total Hgt wo/cap	1.0'	1.5'	2'	2.5'	3'	3.5'	4'	4.5'	5'	5.5'	6'	6.5'	7'	7.5'	8'	8.5'	9'
Grid Sq Yd per Ln Ft	0.000	0.444	0.472	0.889	0.972	1.111	1.917	2.167	2.333	3.444	3.778	5.139	5.556	5.833	6.250	8.000	8.500
Grid total depth	-	4.00	4.25	8.00	8.75	10.00	17.25	19.50	21.00	31.00	34.00	46.25	50.00	52.50	56.25	72.00	76.50
Sq Ft Block/Ln Ft	2.40	3.60	4.80	6.00	7.20	8.40	9.60	10.80	12.00	13.20	14.40	15.60	16.80	18.00	19.20	20.40	21.60
# Cap per Ln Ft	1.00	1.00	1.00	1.00	1.00	1.00	1.00	1.00	1.00	1.00	1.00	1.00	1.00	1.00	1.00	1.00	1.00

See "Material Estimating" for Adhesive estimate

Geogrid: SRW Universal 635 LTDS or SRW 3 Series 1093 LTDS • Block Dimensions: 6"(H) x 8", 10" OR 12" (W) x 10"(D) • Avg Cover: .4167 Sq.Ft.

If used without the stamped engineering, the final determination of the suitability of the contemplated use, and its manner of use, are the sole responsibility of the user, and the user expressly releases HTS, SRW, and retaining wall unit supplier of any and all liability that might arise as a result. These designs have been performed with National Concrete Masonry Association (NCMA) software and have been analyzed for the appropriate factors of safety. © 2009 Hardscape Technical Services • Maytrx® is a registered trademark of Maytrx Premier Stone System.

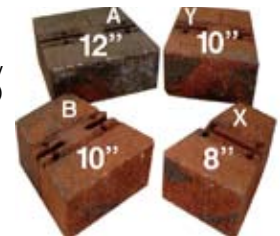

30 DEGREE SOIL for walls up to 8'

Maytrx® Block • SRW Accessories

32 DEGREE SOIL for walls up to 8'

Maytrx® Block • SRW Accessories

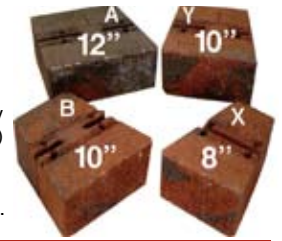

If used without the stamped engineering, the final determination of the suitability of the contemplated use, and its manner of use, are the sole responsibility of the user, and the user expressly releases HTS, SRW, and retaining wall unit supplier of any and all liability that might arise as a result. These designs have been performed with National Concrete Masonry Association (NCMA) software and have been analyzed for the appropriate factors of safety. © 2009 Hardscape Technical Services • Maytrx® is a registered trademark of Maytrx Premier Stone System.

Geogrid: SRW Universal 635 LTDS or SRW 3 Series 1093 LTDS • Block Dimensions: 6"(H) x 8", 10" OR 12" (W) x 10"(D) • Avg Cover: .4167 Sq.Ft.

CASE A

- "CASE A" Retaining Wall:**
- Flat Ground at Top of Wall
 - Flat Ground at Bottom of Wall
 - No Surcharge on Wall

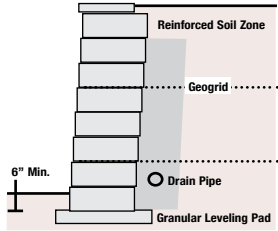

IF STAMPED ENGINEERING IS REQUIRED FOR THIS RETAINING WALL: THIS DESIGN MUST BE STAMPED HERE BY A LICENSED ENGINEER.

GEOGRID PLACEMENT

Note: Grid measurements start from the face of the wall.

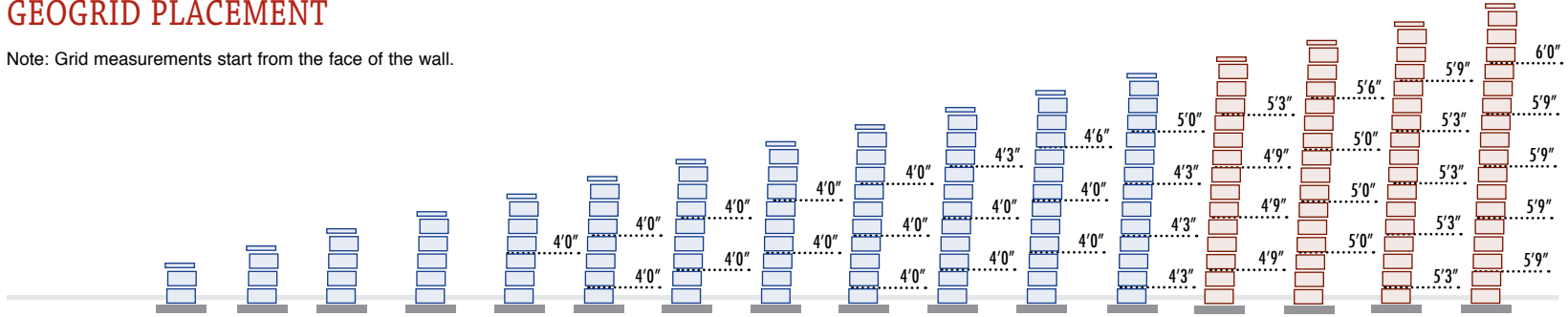

Geogrid Type	SRW Universal - or - SRW 3 Series Grid												SRW 3 Series Grid ONLY			
	0'6"	1'0"	1'6"	2'0"	2'6"	3'0"	3'6"	4'0"	4'6"	5'0"	5'6"	6'0"	6'6"	7'0"	7'6"	8'0"
Exposed Hgt wo/cap	0'6"	1'0"	1'6"	2'0"	2'6"	3'0"	3'6"	4'0"	4'6"	5'0"	5'6"	6'0"	6'6"	7'0"	7'6"	8'0"
Amount Buried	6"	6"	6"	6"	6"	6"	6"	6"	6"	6"	6"	6"	6"	6"	6"	6"
Total Hgt wo/cap	1.0'	1.5'	2'	2.5'	3'	3.5'	4'	4.5'	5'	5.5'	6'	6.5'	7'	7.5'	8'	8.5'
Grid Sq Yd per Ln Ft	0.000	0.000	0.000	0.000	0.444	0.889	0.889	0.889	1.333	1.361	1.389	1.972	2.167	2.278	2.972	3.222
Grid total depth	-	-	-	-	4.00	8.00	8.00	8.00	12.00	12.25	12.50	17.75	19.50	20.50	26.25	29.00
Sq Ft Block/Ln Ft	2.40	3.60	4.80	6.00	7.20	8.40	9.60	10.80	12.00	13.20	14.40	15.60	16.80	18.00	19.20	20.40
# Cap per Ln Ft	1.00	1.00	1.00	1.00	1.00	1.00	1.00	1.00	1.00	1.00	1.00	1.00	1.00	1.00	1.00	1.00

See "Material Estimating" for Adhesive estimate

CASE B

- "CASE B" Retaining Wall:**
- Flat Ground at Top of Wall
 - Flat Ground at Bottom of Wall
 - 100 psf Surcharge on Wall

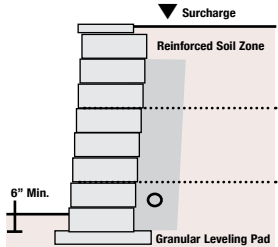

IF STAMPED ENGINEERING IS REQUIRED FOR THIS RETAINING WALL: THIS DESIGN MUST BE STAMPED HERE BY A LICENSED ENGINEER.

GEOGRID PLACEMENT

Note: Grid measurements start from the face of the wall.
• 100 psf Surcharge is light traffic i.e. car or pickup

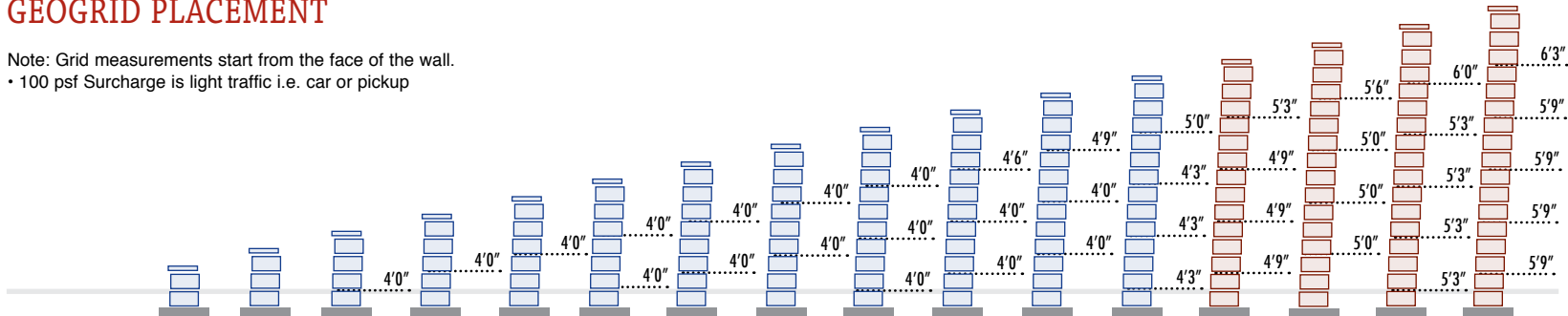

Geogrid Type	SRW Universal - or - SRW 3 Series Grid												SRW 3 Series Grid ONLY			
	0'6"	1'0"	1'6"	2'0"	2'6"	3'0"	3'6"	4'0"	4'6"	5'0"	5'6"	6'0"	6'6"	7'0"	7'6"	8'0"
Exposed Hgt wo/cap	0'6"	1'0"	1'6"	2'0"	2'6"	3'0"	3'6"	4'0"	4'6"	5'0"	5'6"	6'0"	6'6"	7'0"	7'6"	8'0"
Amount Buried	6"	6"	6"	6"	6"	6"	6"	6"	6"	6"	6"	6"	6"	6"	6"	6"
Total Hgt wo/cap	1.0'	1.5'	2'	2.5'	3'	3.5'	4'	4.5'	5'	5.5'	6'	6.5'	7'	7.5'	8'	8.5'
Grid Sq Yd per Ln Ft	0.000	0.000	0.444	0.444	0.444	0.889	0.889	1.889	1.333	1.389	1.417	1.972	2.167	2.278	3.000	3.250
Grid total depth	-	-	4.00	4.00	4.00	8.00	8.00	8.00	12.00	12.50	12.75	17.75	19.50	20.50	27.00	29.25
Sq Ft Block/Ln Ft	2.40	3.60	4.80	6.00	7.20	8.40	9.60	10.80	12.00	13.20	14.40	15.60	16.80	18.00	19.20	20.40
# Cap per Ln Ft	1.00	1.00	1.00	1.00	1.00	1.00	1.00	1.00	1.00	1.00	1.00	1.00	1.00	1.00	1.00	1.00

See "Material Estimating" for Adhesive estimate

CASE C

- "CASE C" Retaining Wall:**
- Flat Ground at Top of Wall
 - Flat Ground at Bottom of Wall
 - 250 psf Surcharge on Wall

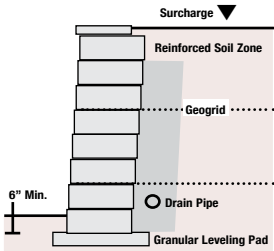

IF STAMPED ENGINEERING IS REQUIRED FOR THIS RETAINING WALL: THIS DESIGN MUST BE STAMPED HERE BY A LICENSED ENGINEER.

GEOGRID PLACEMENT

- Note: Grid measurements start from the face of the wall.
- Surcharge begins two feet behind wall facing.
 - 250 psf Surcharge is heavier traffic i.e. RV, large vehicle

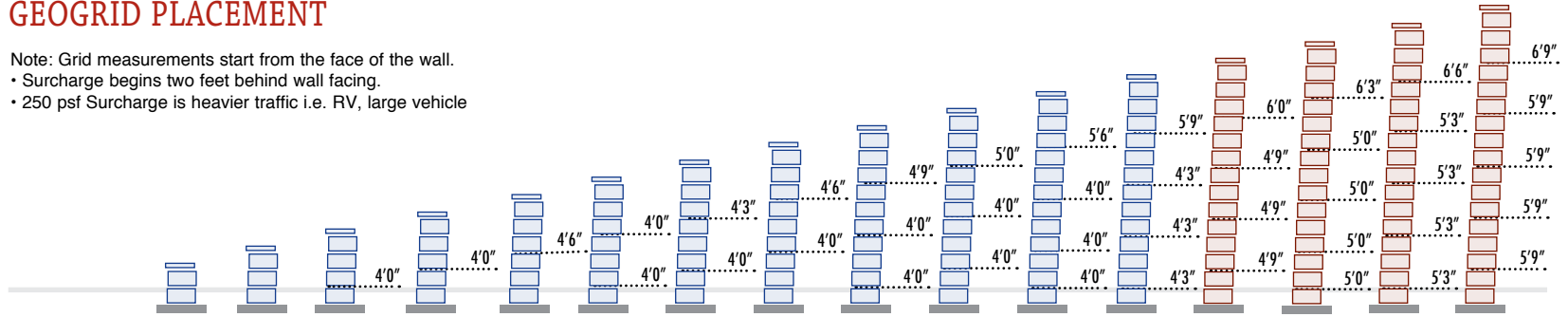

Geogrid Type	SRW Universal - or - SRW 3 Series Grid												SRW 3 Series Grid ONLY			
	0'6"	1'0"	1'6"	2'0"	2'6"	3'0"	3'6"	4'0"	4'6"	5'0"	5'6"	6'0"	6'6"	7'0"	7'6"	8'0"
Exposed Hgt wo/cap	0'6"	1'0"	1'6"	2'0"	2'6"	3'0"	3'6"	4'0"	4'6"	5'0"	5'6"	6'0"	6'6"	7'0"	7'6"	8'0"
Amount Buried	6"	6"	6"	6"	6"	6"	6"	6"	6"	6"	6"	6"	6"	6"	6"	6"
Total Hgt wo/cap	1.0'	1.5'	2'	2.5'	3'	3.5'	4'	4.5'	5'	5.5'	6'	6.5'	7'	7.5'	8'	8.5'
Grid Sq Yd per Ln Ft	0.000	0.000	0.444	0.444	0.500	0.889	0.917	0.944	1.417	1.444	1.944	2.056	2.250	2.917	3.056	3.306
Grid total depth	-	-	4.00	4.00	4.50	8.00	8.25	8.50	12.75	13.00	17.50	18.50	20.25	26.25	27.50	29.75
Sq Ft Block/Ln Ft	2.40	3.60	4.80	6.00	7.20	8.40	9.60	10.80	12.00	13.20	14.40	15.60	16.80	18.00	19.20	20.40
# Cap per Ln Ft	1.00	1.00	1.00	1.00	1.00	1.00	1.00	1.00	1.00	1.00	1.00	1.00	1.00	1.00	1.00	1.00

See "Material Estimating" for Adhesive estimate

CASE D

- "CASE D" Retaining Wall:**
- 4/1 Slope at Top of Wall
 - Flat Ground at Bottom of Wall
 - No Surcharge on Wall

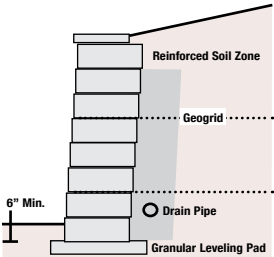

IF STAMPED ENGINEERING IS REQUIRED FOR THIS RETAINING WALL: THIS DESIGN MUST BE STAMPED HERE BY A LICENSED ENGINEER.

GEOGRID PLACEMENT

- Note: Grid measurements start from the face of the wall.

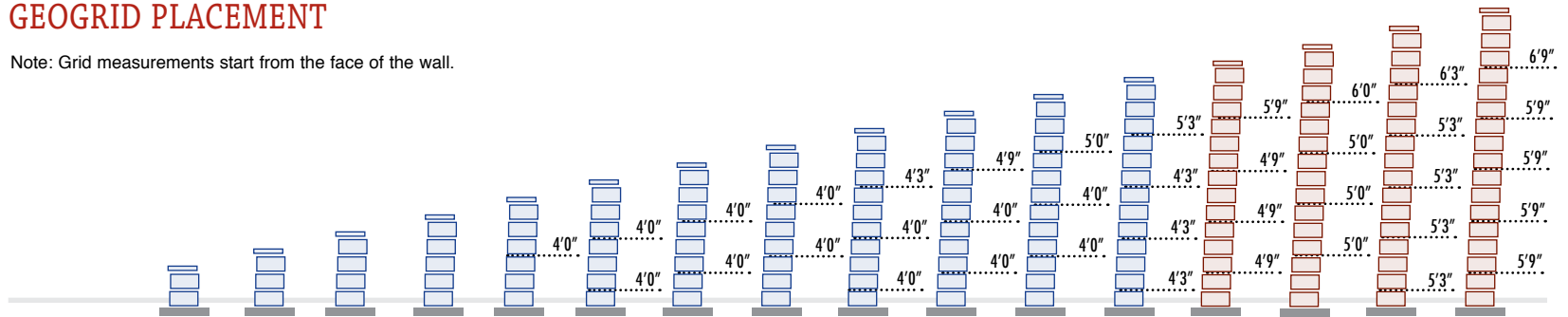

Geogrid Type	SRW Universal - or - SRW 3 Series Grid												SRW 3 Series Grid ONLY			
	0'6"	1'0"	1'6"	2'0"	2'6"	3'0"	3'6"	4'0"	4'6"	5'0"	5'6"	6'0"	6'6"	7'0"	7'6"	8'0"
Exposed Hgt wo/cap	0'6"	1'0"	1'6"	2'0"	2'6"	3'0"	3'6"	4'0"	4'6"	5'0"	5'6"	6'0"	6'6"	7'0"	7'6"	8'0"
Amount Buried	6"	6"	6"	6"	6"	6"	6"	6"	6"	6"	6"	6"	6"	6"	6"	6"
Total Hgt wo/cap	1.0'	1.5'	2'	2.5'	3'	3.5'	4'	4.5'	5'	5.5'	6'	6.5'	7'	7.5'	8'	8.5'
Grid Sq Yd per Ln Ft	0.000	0.000	0.000	0.000	0.444	0.889	0.889	0.889	1.361	1.417	1.444	2.000	2.222	2.333	3.028	3.306
Grid total depth	-	-	-	-	4.00	8.00	8.00	8.00	12.25	12.75	13.00	18.00	20.00	21.00	27.25	29.75
Sq Ft Block/Ln Ft	2.40	3.60	4.80	6.00	7.20	8.40	9.60	10.80	12.00	13.20	14.40	15.60	16.80	18.00	19.20	20.40
# Cap per Ln Ft	1.00	1.00	1.00	1.00	1.00	1.00	1.00	1.00	1.00	1.00	1.00	1.00	1.00	1.00	1.00	1.00

See "Material Estimating" for Adhesive estimate

Geogrid: SRW Universal 635 LTDS or SRW 3 Series 1093 LTDS • Block Dimensions: 6"(H) x 8", 10" OR 12" (W) x 10"(D) • Avg Cover: .4167 Sq.Ft.

If used without the stamped engineering, the final determination of the suitability of the contemplated use, and its manner of use, are the sole responsibility of the user, and the user expressly releases HTS, SRW, and retaining wall unit supplier of any and all liability that might arise as a result. These designs have been performed with National Concrete Masonry Association (NCMA) software and have been analyzed for the appropriate factors of safety. © 2009 Hardscape Technical Services • Maytrx® is a registered trademark of Maytrx Premier Stone System.



32 DEGREE SOIL

for walls up to 8'

Maytrx® Block • SRW Accessories

32 DEGREE SOIL for walls up to 8'

Maytrx® Block • SRW Accessories

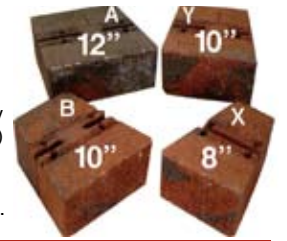

If used without the stamped engineering, the final determination of the suitability of the contemplated use, and its manner of use, are the sole responsibility of the user, and the user expressly releases HTS, SRW, and retaining wall unit supplier of any and all liability that might arise as a result. These designs have been performed with National Concrete Masonry Association (NCMA) software and have been analyzed for the appropriate factors of safety. © 2009 Hardscape Technical Services • Maytrx® is a registered trademark of Maytrx Premier Stone System.

Geogrid: SRW Universal 635 LTDS or SRW 3 Series 1093 LTDS • Block Dimensions: 6"(H) x 8", 10" OR 12" (W) x 10"(D) • Avg Cover: .4167 Sq.Ft.

CASE E

- "CASE E" Retaining Wall:**
- 2/1 Slope at Top of Wall
 - Flat Ground at Bottom of Wall
 - No Surcharge on Wall

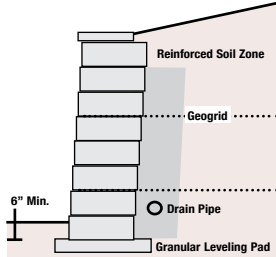

IF STAMPED ENGINEERING IS REQUIRED FOR THIS RETAINING WALL: THIS DESIGN MUST BE STAMPED HERE BY A LICENSED ENGINEER.

GEOGRID PLACEMENT

Note: Grid measurements start from the face of the wall.

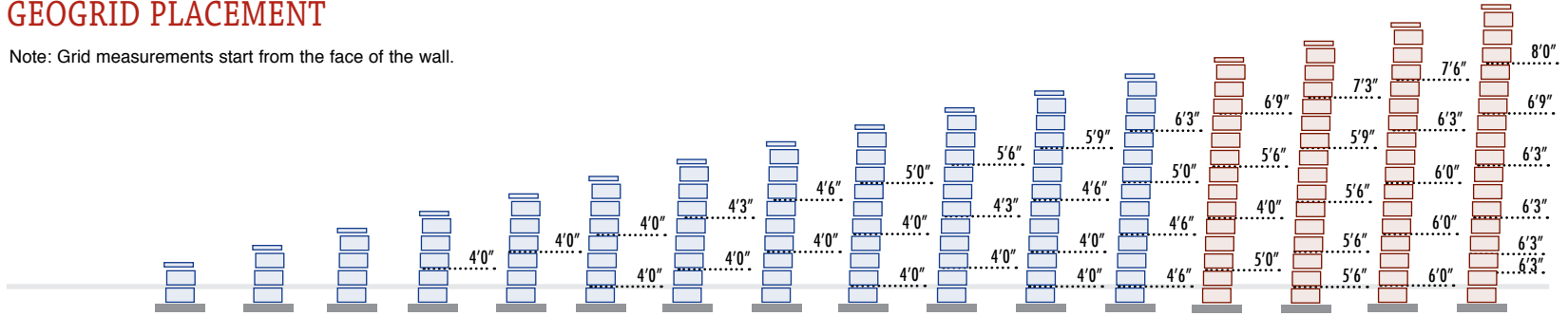

Geogrid Type	SRW Universal - or - SRW 3 Series Grid												SRW 3 Series Grid ONLY			
	0'6"	1'0"	1'6"	2'0"	2'6"	3'0"	3'6"	4'0"	4'6"	5'0"	5'6"	6'0"	6'6"	7'0"	7'6"	8'0"
Exposed Hgt wo/cap	0'6"	1'0"	1'6"	2'0"	2'6"	3'0"	3'6"	4'0"	4'6"	5'0"	5'6"	6'0"	6'6"	7'0"	7'6"	8'0"
Amount Buried	6"	6"	6"	6"	6"	6"	6"	6"	6"	6"	6"	6"	6"	6"	6"	6"
Total Hgt wo/cap	1.0'	1.5'	2'	2.5'	3'	3.5'	4'	4.5'	5'	5.5'	6'	6.5'	7'	7.5'	8'	8.5'
Grid Sq Yd per Ln Ft	0.000	0.000	0.000	0.444	0.444	0.889	0.917	0.944	1.444	1.528	2.028	2.250	2.472	3.278	3.528	4.417
Grid total depth	-	-	-	4.00	4.00	8.00	8.25	8.50	13.00	13.75	18.25	20.25	22.25	29.50	31.75	39.75
Sq Ft Block/Ln Ft	2.40	3.60	4.80	6.00	7.20	8.40	9.60	10.80	12.00	13.20	14.40	15.60	16.80	18.00	19.20	20.40
# Cap per Ln Ft	1.00	1.00	1.00	1.00	1.00	1.00	1.00	1.00	1.00	1.00	1.00	1.00	1.00	1.00	1.00	1.00

See "Material Estimating" for Adhesive estimate

CASE F

- "CASE F" Retaining Wall:**
- Flat Ground at Top of Wall
 - 5/1 Slope at Bottom of Wall
 - No Surcharge on Wall

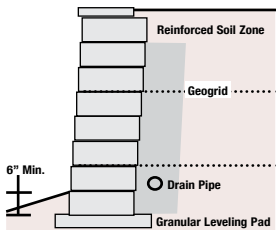

IF STAMPED ENGINEERING IS REQUIRED FOR THIS RETAINING WALL: THIS DESIGN MUST BE STAMPED HERE BY A LICENSED ENGINEER.

GEOGRID PLACEMENT

Note: Grid measurements start from the face of the wall.

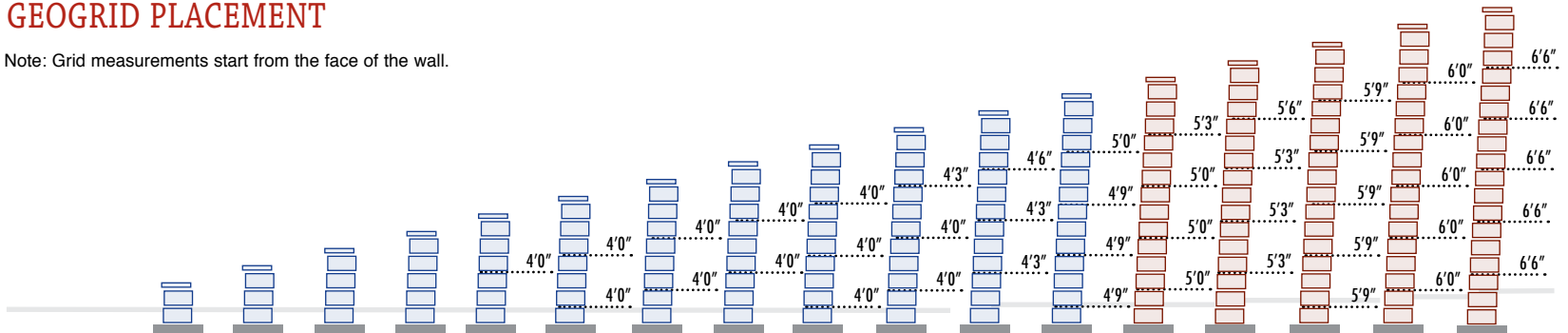

Geogrid Type	SRW Universal - or - SRW 3 Series Grid												SRW 3 Series Grid ONLY				
	0'6"	1'0"	1'6"	2'0"	2'6"	3'0"	3'6"	4'0"	4'6"	5'0"	5'5"	5'10"	6'4"	6'9"	7'3"	7'8"	8'0"
Exposed Hgt wo/cap	0'6"	1'0"	1'6"	2'0"	2'6"	3'0"	3'6"	4'0"	4'6"	5'0"	5'5"	5'10"	6'4"	6'9"	7'3"	7'8"	8'0"
Amount Buried	6"	6"	6"	6"	6"	6"	6"	6"	6"	6"	6"	6"	8"	9"	9"	10"	10"
Total Hgt wo/cap	1.0'	1.5'	2'	2.5'	3'	3.5'	4'	4.5'	5'	5.5'	6'	6.5'	7'	7.5'	8'	8.5'	9'
Grid Sq Yd per Ln Ft	0.000	0.000	0.000	0.000	0.444	0.889	0.889	0.889	1.333	1.361	1.444	2.139	2.250	2.361	3.194	3.333	3.611
Grid total depth	-	-	-	-	4.00	8.00	8.00	8.00	12.00	12.25	13.00	19.25	20.25	21.25	28.75	30.00	32.50
Sq Ft Block/Ln Ft	2.40	3.60	4.80	6.00	7.20	8.40	9.60	10.80	12.00	13.20	14.40	15.60	16.80	18.00	19.20	20.40	21.60
# Cap per Ln Ft	1.00	1.00	1.00	1.00	1.00	1.00	1.00	1.00	1.00	1.00	1.00	1.00	1.00	1.00	1.00	1.00	1.00

See "Material Estimating" for Adhesive estimate

CASE G

- "CASE G" Retaining Wall:**
- Flat Ground at Top of Wall
 - 5/1 Slope at Bottom of Wall
 - 100 psf Surcharge on Wall

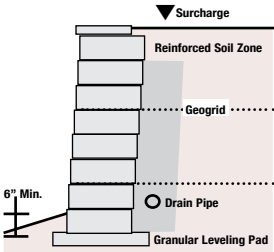

IF STAMPED ENGINEERING IS REQUIRED FOR THIS RETAINING WALL: THIS DESIGN MUST BE STAMPED HERE BY A LICENSED ENGINEER.

GEOGRID PLACEMENT

- Note: Grid measurements start from the face of the wall.
- 100 psf Surcharge is light traffic i.e. car or pickup

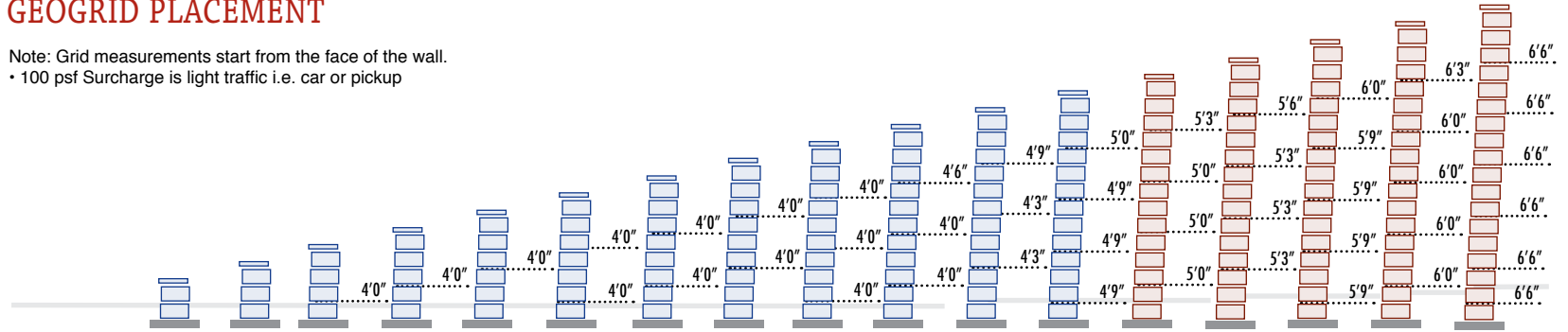

Geogrid Type	SRW Universal - or - SRW 3 Series Grid											SRW 3 Series Grid ONLY					
Exposed Hgt wo/cap	0'6"	1'0"	1'6"	2'0"	2'6"	3'0"	3'6"	4'0"	4'6"	5'0"	5'5"	5'10"	6'4"	6'9"	7'3"	7'8"	8'0"
Amount Buried	6"	6"	6"	6"	6"	6"	6"	6"	6"	6"	7"	8"	8"	9"	9"	10"	1'0"
Total Hgt wo/cap	1.0'	1.5'	2'	2.5'	3'	3.5'	4'	4.5'	5'	5.5'	6'	6.5'	7'	7.5'	8'	8.5'	9'
Grid Sq Yd per Ln Ft	0.000	0.000	0.444	0.444	0.444	0.889	0.889	0.889	1.333	1.389	1.472	2.139	2.250	2.361	3.222	3.361	4.333
Grid total depth	-	-	4.00	4.00	4.00	8.00	8.00	8.00	12.00	12.50	13.25	19.25	20.25	21.25	29.00	30.25	39.00
Sq Ft Block/Ln Ft	2.40	3.60	4.80	6.00	7.20	8.40	9.60	10.80	12.00	13.20	14.40	15.60	16.80	18.00	19.20	20.40	21.60
# Cap per Ln Ft	1.00	1.00	1.00	1.00	1.00	1.00	1.00	1.00	1.00	1.00	1.00	1.00	1.00	1.00	1.00	1.00	1.00

See "Material Estimating" for Adhesive estimate

CASE H

- "CASE H" Retaining Wall:**
- Flat Ground at Top of Wall
 - 5/1 Slope at Bottom of Wall
 - 250 psf Surcharge on Wall

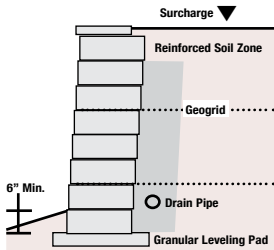

IF STAMPED ENGINEERING IS REQUIRED FOR THIS RETAINING WALL: THIS DESIGN MUST BE STAMPED HERE BY A LICENSED ENGINEER.

GEOGRID PLACEMENT

- Note: Grid measurements start from the face of the wall.
- Surcharge begins two feet behind wall facing.
 - 250 psf Surcharge is heavier traffic i.e. RV, large vehicle

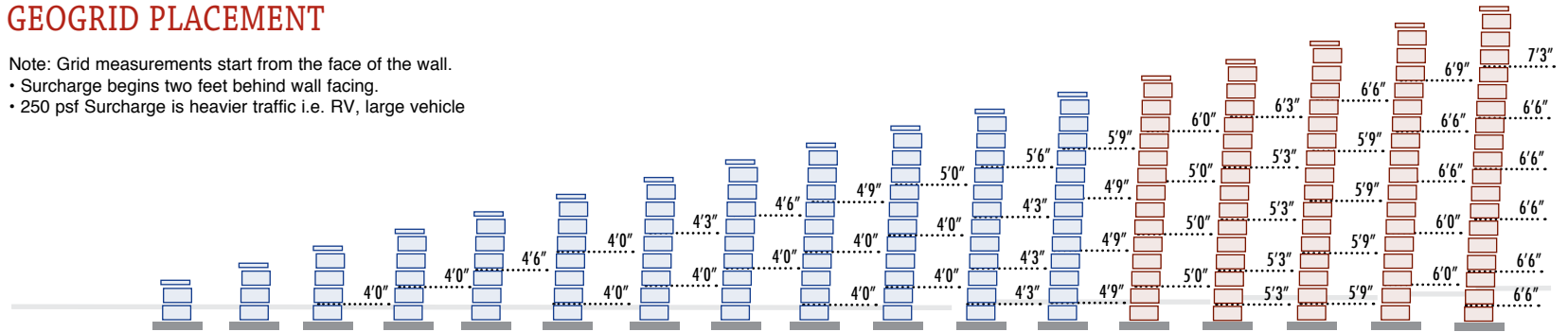

Geogrid Type	SRW Universal - or - SRW 3 Series Grid											SRW 3 Series Grid ONLY					
Exposed Hgt wo/cap	0'6"	1'0"	1'6"	2'0"	2'6"	3'0"	3'6"	4'0"	4'6"	5'0"	5'5"	5'10"	6'4"	6'9"	7'3"	7'8"	8'0"
Amount Buried	6"	6"	6"	6"	6"	6"	6"	6"	6"	6"	7"	8"	8"	9"	9"	10"	1'0"
Total Hgt wo/cap	1.0'	1.5'	2'	2.5'	3'	3.5'	4'	4.5'	5'	5.5'	6'	6.5'	7'	7.5'	8'	8.5'	9'
Grid Sq Yd per Ln Ft	0.000	0.000	0.444	0.444	0.500	0.889	0.917	0.944	1.417	1.444	2.028	2.222	2.333	3.028	3.278	3.417	4.417
Grid total depth	-	-	4.00	4.00	4.50	8.00	8.25	8.50	12.75	13.00	18.75	20.00	21.00	27.25	29.50	30.75	39.75
Sq Ft Block/Ln Ft	2.40	3.60	4.80	6.00	7.20	8.40	9.60	10.80	12.00	13.20	14.40	15.60	16.80	18.00	19.20	20.40	21.60
# Cap per Ln Ft	1.00	1.00	1.00	1.00	1.00	1.00	1.00	1.00	1.00	1.00	1.00	1.00	1.00	1.00	1.00	1.00	1.00

See "Material Estimating" for Adhesive estimate

Geogrid: SRW Universal 635 LTDS or SRW 3 Series 1093 LTDS • Block Dimensions: 6"(H) x 8", 10" OR 12" (W) x 10"(D) • Avg Cover: .4167 Sq.Ft.

If used without the stamped engineering, the final determination of the suitability of the contemplated use, and its manner of use, are the sole responsibility of the user, and the user expressly releases HTS, SRW, and retaining wall unit supplier of any and all liability that might arise as a result. These designs have been performed with National Concrete Masonry Association (NCMA) software and have been analyzed for the appropriate factors of safety. © 2009 Hardscape Technical Services • Maytrx® is a registered trademark of Maytrx Premier Stone System.

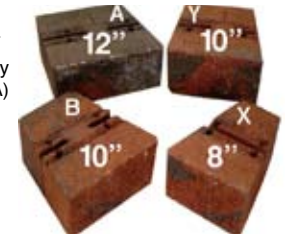

32 DEGREE SOIL

for walls up to 8'

Maytrx® Block • SRW Accessories

32 DEGREE SOIL for walls up to 8'

Maytrx® Block • SRW Accessories

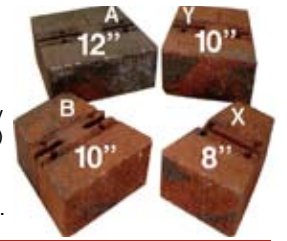

If used without the stamped engineering, the final determination of the suitability of the contemplated use, and its manner of use, are the sole responsibility of the user, and the user expressly releases HTS, SRW, and retaining wall unit supplier of any and all liability that might arise as a result. These designs have been performed with National Concrete Masonry Association (NCMA) software and have been analyzed for the appropriate factors of safety. © 2009 Hardscape Technical Services • Maytrx® is a registered trademark of Maytrx Premier Stone System.

Geogrid: SRW Universal 635 LTDS or SRW 3 Series 1093 LTDS • Block Dimensions: 6”(H) x 8”, 10” OR 12” (W) x 10”(D) • Avg Cover: .4167 Sq.Ft.

CASE I

- “CASE I” Retaining Wall:**
- Flat Ground at Top of Wall
 - 4/1 Slope at Bottom of Wall
 - No Surcharge on Wall

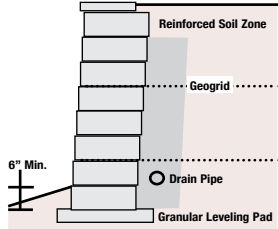

IF STAMPED ENGINEERING IS REQUIRED FOR THIS RETAINING WALL: THIS DESIGN MUST BE STAMPED HERE BY A LICENSED ENGINEER.

GEOGRID PLACEMENT

Note: Grid measurements start from the face of the wall.

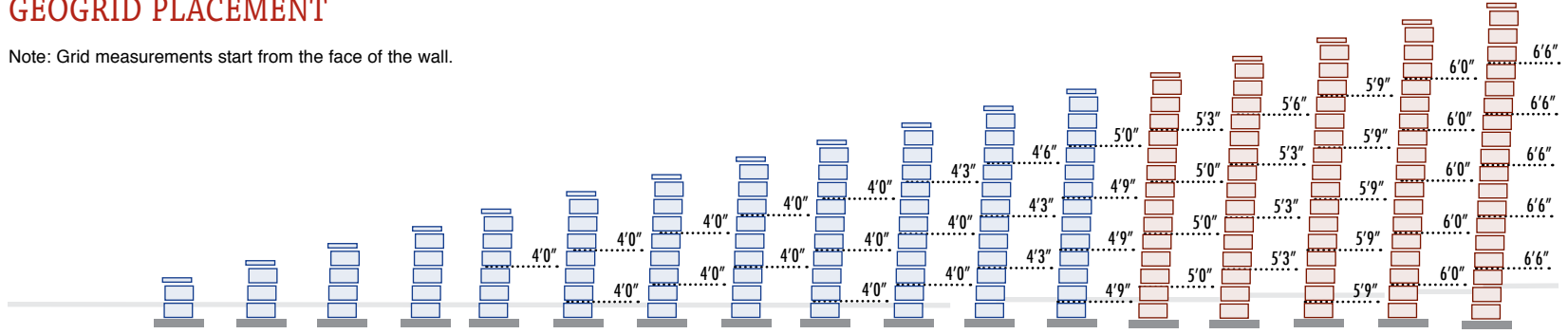

Geogrid Type	SRW Universal - or - SRW 3 Series Grid												SRW 3 Series Grid ONLY				
	0'6"	1'0"	1'6"	2'0"	2'6"	3'0"	3'6"	4'0"	4'6"	5'0"	5'5"	5'10"	6'4"	6'9"	7'3"	7'8"	8'0"
Exposed Hgt wo/cap	6"	6"	6"	6"	6"	6"	6"	6"	6"	6"	6"	6"	8"	9"	9"	10"	10"
Amount Buried	1.0'	1.5'	2'	2.5'	3'	3.5'	4'	4.5'	5'	5.5'	6'	6.5'	7'	7.5'	8'	8.5'	9'
Total Hgt wo/cap	0.000	0.000	0.000	0.000	0.444	0.889	0.889	0.889	1.333	1.361	1.444	2.139	2.250	2.361	3.194	3.333	3.611
Grid Sq Yd per Ln Ft	-	-	-	-	4.00	8.00	8.00	8.00	12.00	12.25	13.00	19.25	20.25	21.25	28.75	30.00	32.50
Grid total depth	2.40	3.60	4.80	6.00	7.20	8.40	9.60	10.80	12.00	13.20	14.40	15.60	16.80	18.00	19.20	20.40	21.60
Sq Ft Block/Ln Ft	1.00	1.00	1.00	1.00	1.00	1.00	1.00	1.00	1.00	1.00	1.00	1.00	1.00	1.00	1.00	1.00	1.00
# Cap per Ln Ft																	

See "Material Estimating" for Adhesive estimate

CASE J

- “CASE J” Retaining Wall:**
- Flat Ground at Top of Wall
 - 4/1 Slope at Bottom of Wall
 - 100 psf Surcharge on Wall

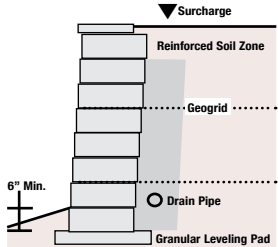

IF STAMPED ENGINEERING IS REQUIRED FOR THIS RETAINING WALL: THIS DESIGN MUST BE STAMPED HERE BY A LICENSED ENGINEER.

GEOGRID PLACEMENT

Note: Grid measurements start from the face of the wall.
• 100 psf Surcharge is light traffic i.e. car or pickup

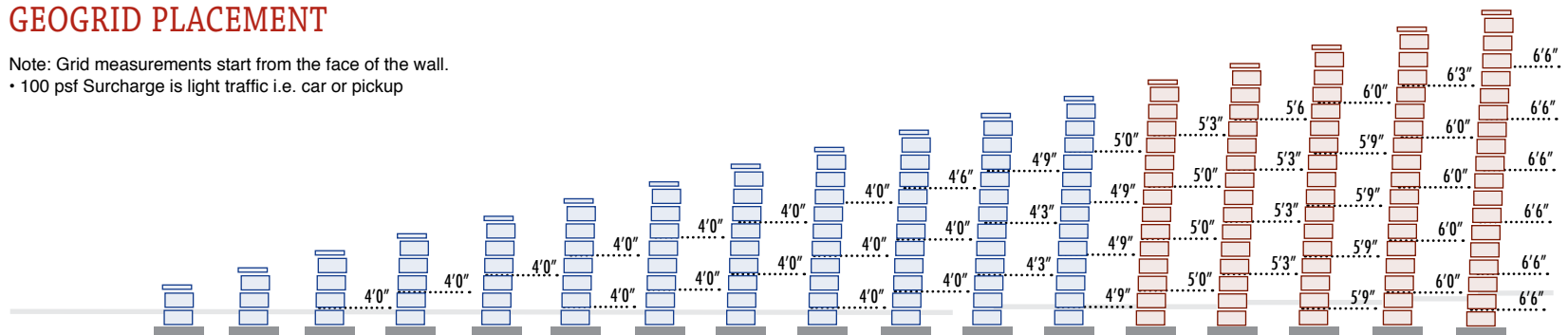

Geogrid Type	SRW Universal - or - SRW 3 Series Grid												SRW 3 Series Grid ONLY				
	0'6"	1'0"	1'6"	2'0"	2'6"	3'0"	3'6"	4'0"	4'6"	5'0"	5'5"	5'10"	6'4"	6'9"	7'3"	7'8"	8'0"
Exposed Hgt wo/cap	6"	6"	6"	6"	6"	6"	6"	6"	6"	6"	6"	6"	8"	9"	9"	10"	10"
Amount Buried	1.0'	1.5'	2'	2.5'	3'	3.5'	4'	4.5'	5'	5.5'	6'	6.5'	7'	7.5'	8'	8.5'	9'
Total Hgt wo/cap	0.000	0.000	0.444	0.444	0.444	0.889	0.889	0.889	1.333	1.389	1.472	2.139	2.250	2.361	3.222	3.361	4.333
Grid Sq Yd per Ln Ft	-	-	4.00	4.00	4.00	8.00	8.00	8.00	12.00	12.50	13.25	19.25	20.25	21.25	29.00	30.25	39.00
Grid total depth	2.40	3.60	4.80	6.00	7.20	8.40	9.60	10.80	12.00	13.20	14.40	15.60	16.80	18.00	19.20	20.40	21.60
Sq Ft Block/Ln Ft	1.00	1.00	1.00	1.00	1.00	1.00	1.00	1.00	1.00	1.00	1.00	1.00	1.00	1.00	1.00	1.00	1.00
# Cap per Ln Ft																	

See "Material Estimating" for Adhesive estimate

CASE K

- "CASE K" Retaining Wall:**
- Flat Ground at Top of Wall
 - 4/1 Slope at Bottom of Wall
 - 250 psf Surcharge on Wall

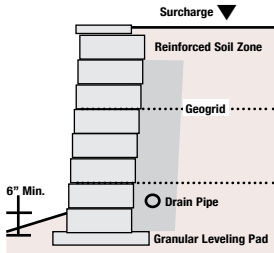

IF STAMPED ENGINEERING IS REQUIRED FOR THIS RETAINING WALL: THIS DESIGN MUST BE STAMPED HERE BY A LICENSED ENGINEER.

GEOGRID PLACEMENT

- Note: Grid measurements start from the face of the wall.
- Surcharge begins two feet behind wall facing.
 - 250 psf Surcharge is heavier traffic i.e. RV, large vehicle

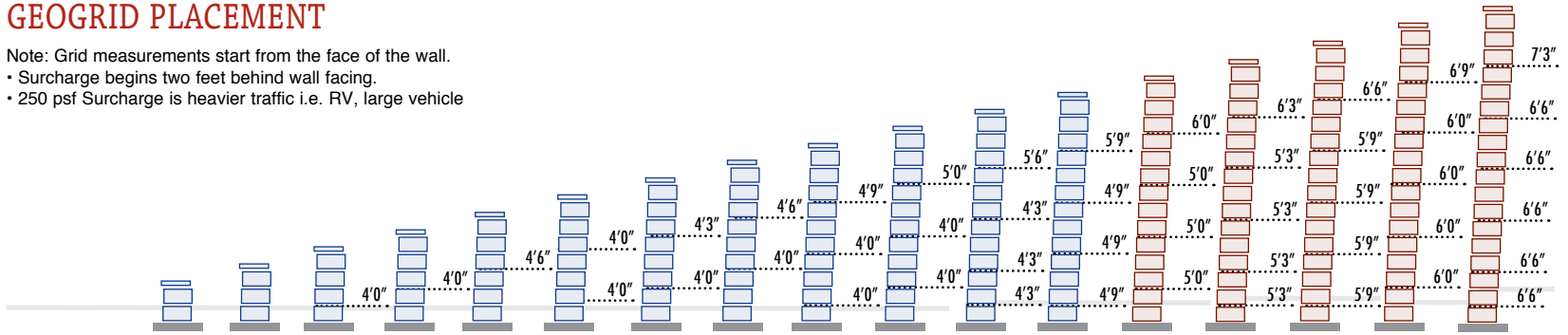

Geogrid Type	SRW Universal - or - SRW 3 Series Grid												SRW 3 Series Grid ONLY				
	0'6"	1'0"	1'6"	2'0"	2'6"	3'0"	3'6"	4'0"	4'6"	5'0"	5'5"	5'10"	6'4"	6'9"	7'3"	7'8"	8'0"
Exposed Hgt wo/cap	6"	6"	6"	6"	6"	6"	6"	6"	6"	6"	7"	8"	8"	9"	9"	10"	1'0"
Amount Buried	1.0'	1.5'	2'	2.5'	3'	3.5'	4'	4.5'	5'	5.5'	6'	6.5'	7'	7.5'	8'	8.5'	9'
Total Hgt wo/cap	0.000	0.000	0.444	0.444	0.500	0.889	0.917	0.944	1.417	1.444	2.028	2.222	2.333	3.028	3.278	3.417	4.417
Grid Sq Yd per Ln Ft	-	-	4.00	4.00	4.50	8.00	8.25	8.50	12.75	13.00	18.25	20.00	21.00	27.25	29.50	30.75	39.75
Grid total depth	2.40	3.60	4.80	6.00	7.20	8.40	9.60	10.80	12.00	13.20	14.40	15.60	16.80	18.00	19.20	20.40	21.60
Sq Ft Block/Ln Ft	1.00	1.00	1.00	1.00	1.00	1.00	1.00	1.00	1.00	1.00	1.00	1.00	1.00	1.00	1.00	1.00	1.00
# Cap per Ln Ft																	

See "Material Estimating" for Adhesive estimate

CASE L

- "CASE L" Retaining Wall:**
- Flat Ground at Top of Wall
 - 3/1 Slope at Bottom of Wall
 - No Surcharge on Wall

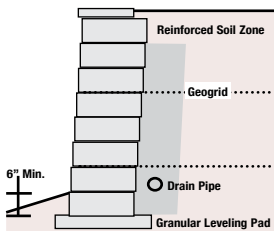

IF STAMPED ENGINEERING IS REQUIRED FOR THIS RETAINING WALL: THIS DESIGN MUST BE STAMPED HERE BY A LICENSED ENGINEER.

GEOGRID PLACEMENT

- Note: Grid measurements start from the face of the wall.

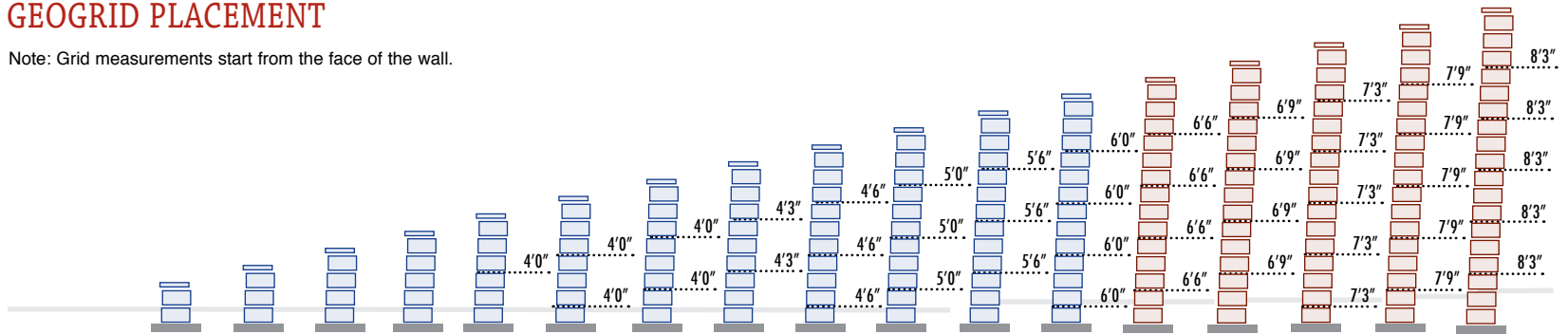

Geogrid Type	SRW Universal - or - SRW 3 Series Grid												SRW 3 Series Grid ONLY				
	0'6"	1'0"	1'6"	2'0"	2'6"	3'0"	3'6"	4'0"	4'6"	5'0"	5'5"	5'10"	6'4"	6'9"	7'3"	7'8"	8'0"
Exposed Hgt wo/cap	6"	6"	6"	6"	6"	6"	6"	6"	6"	7"	8"	8"	8"	9"	9"	10"	1'0"
Amount Buried	1.0'	1.5'	2'	2.5'	3'	3.5'	4'	4.5'	5'	5.5'	6'	6.5'	7'	7.5'	8'	8.5'	9'
Total Hgt wo/cap	0.000	0.000	0.000	0.000	0.444	0.889	0.889	0.944	1.500	1.667	1.833	2.667	2.889	3.000	4.028	4.306	4.583
Grid Sq Yd per Ln Ft	-	-	-	-	4.00	8.00	8.00	8.50	13.50	15.00	16.50	24.00	26.00	27.00	36.25	38.75	41.25
Grid total depth	2.40	3.60	4.80	6.00	7.20	8.40	9.60	10.80	12.00	13.20	14.40	15.60	16.80	18.00	19.20	20.40	21.60
Sq Ft Block/Ln Ft	1.00	1.00	1.00	1.00	1.00	1.00	1.00	1.00	1.00	1.00	1.00	1.00	1.00	1.00	1.00	1.00	1.00
# Cap per Ln Ft																	

See "Material Estimating" for Adhesive estimate

Geogrid: SRW Universal 635 LTDS or SRW 3 Series 1093 LTDS • Block Dimensions: 6"(H) x 8", 10" OR 12" (W) x 10"(D) • Avg Cover: .4167 Sq.Ft.

If used without the stamped engineering, the final determination of the suitability of the contemplated use, and its manner of use, are the sole responsibility of the user, and the user expressly releases HTS, SRW, and retaining wall unit supplier of any and all liability that might arise as a result. These designs have been performed with National Concrete Masonry Association (NCMA) software and have been analyzed for the appropriate factors of safety. © 2009 Hardscape Technical Services • Maytrx® is a registered trademark of Maytrx Premier Stone System.



32 DEGREE SOIL for walls up to 8'

Maytrx® Block • SRW Accessories

32 DEGREE SOIL for walls up to 8'

Maytrx® Block • SRW Accessories

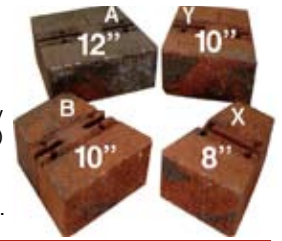

If used without the stamped engineering, the final determination of the suitability of the contemplated use, and its manner of use, are the sole responsibility of the user, and the user expressly releases HTS, SRW, and retaining wall unit supplier of any and all liability that might arise as a result. These designs have been performed with National Concrete Masonry Association (NCMA) software and have been analyzed for the appropriate factors of safety. © 2009 Hardscape Technical Services • Maytrx® is a registered trademark of Maytrx Premier Stone System.

Geogrid: SRW Universal 635 LTDS or SRW 3 Series 1093 LTDS • Block Dimensions: 6\"/>

CASE M

- “CASE M” Retaining Wall:**
- Flat Ground at Top of Wall
 - 3/1 Slope at Bottom of Wall
 - 100 psf Surcharge on Wall

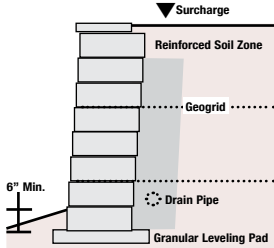

IF STAMPED ENGINEERING IS REQUIRED FOR THIS RETAINING WALL: THIS DESIGN MUST BE STAMPED HERE BY A LICENSED ENGINEER.

GEOGRID PLACEMENT

- Note: Grid measurements start from the face of the wall.
- 100 psf Surcharge is light traffic i.e. car or pickup

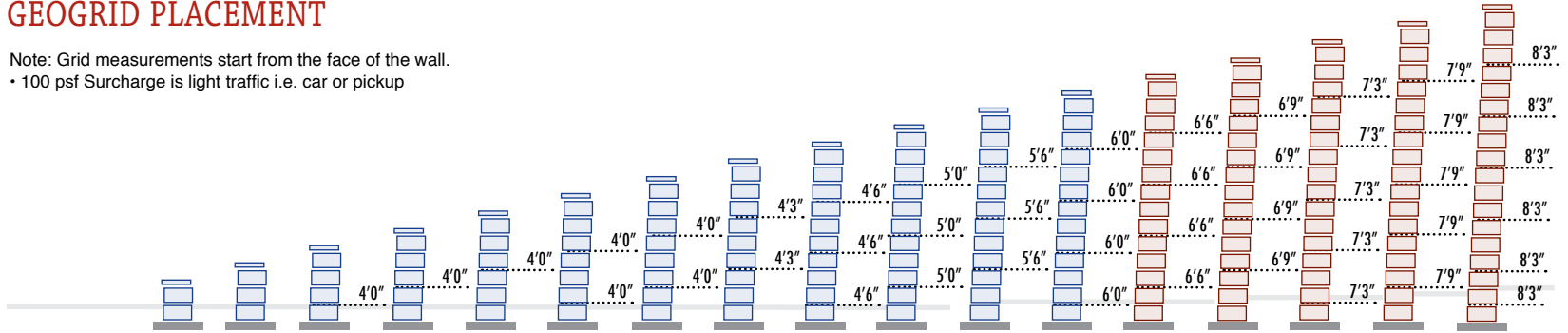

Geogrid Type	SRW Universal - or - SRW 3 Series Grid												SRW 3 Series Grid ONLY				
	0'6"	1'0"	1'6"	2'0"	2'6"	3'0"	3'6"	4'0"	4'6"	5'0"	5'5"	5'10"	6'4"	6'9"	7'3"	7'8"	8'0"
Exposed Hgt wo/cap	6"	6"	6"	6"	6"	6"	6"	6"	6"	6"	7"	8"	8"	9"	9"	10"	10"
Amount Buried	1.0'	1.5'	2'	2.5'	3'	3.5'	4'	4.5'	5'	5.5'	6'	6.5'	7'	7.5'	8'	8.5'	9'
Total Hgt wo/cap	0.000	0.000	0.444	0.444	0.444	0.889	0.889	0.944	1.500	1.667	1.833	2.667	2.889	3.000	4.028	4.306	5.500
Grid Sq Yd per Ln Ft	-	-	4.00	4.00	4.00	8.00	8.00	8.50	13.50	15.00	16.50	24.00	26.00	27.00	36.25	38.75	49.50
Grid total depth	2.40	3.60	4.80	6.00	7.20	8.40	9.60	10.80	12.00	13.20	14.40	15.60	16.80	18.00	19.20	20.40	21.60
Sq Ft Block/Ln Ft	1.00	1.00	1.00	1.00	1.00	1.00	1.00	1.00	1.00	1.00	1.00	1.00	1.00	1.00	1.00	1.00	1.00
# Cap per Ln Ft																	

See "Material Estimating" for Adhesive estimate

CASE N

- “CASE N” Retaining Wall:**
- Flat Ground at Top of Wall
 - 3/1 Slope at Bottom of Wall
 - 250 psf Surcharge on Wall

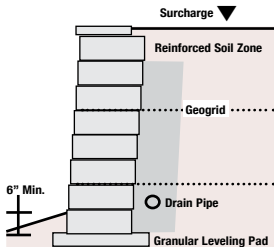

IF STAMPED ENGINEERING IS REQUIRED FOR THIS RETAINING WALL: THIS DESIGN MUST BE STAMPED HERE BY A LICENSED ENGINEER.

GEOGRID PLACEMENT

- Note: Grid measurements start from the face of the wall.
- Surcharge begins two feet behind wall facing.
 - 250 psf Surcharge is heavier traffic i.e. RV, large vehicle

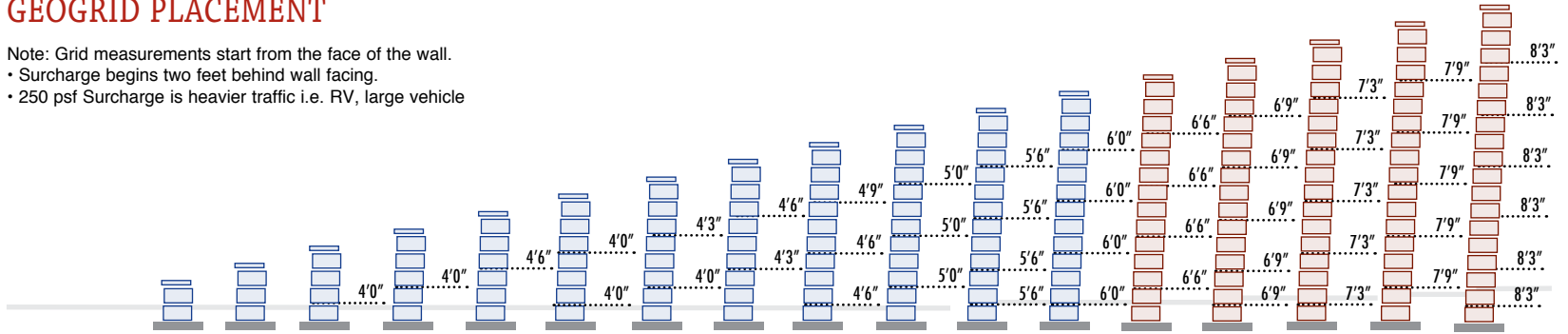

Geogrid Type	SRW Universal - or - SRW 3 Series Grid												SRW 3 Series Grid ONLY				
	0'6"	1'0"	1'6"	2'0"	2'6"	3'0"	3'6"	4'0"	4'6"	5'0"	5'5"	5'10"	6'4"	6'9"	7'3"	7'8"	8'0"
Exposed Hgt wo/cap	6"	6"	6"	6"	6"	6"	6"	6"	6"	6"	7"	8"	8"	9"	9"	10"	10"
Amount Buried	1.0'	1.5'	2'	2.5'	3'	3.5'	4'	4.5'	5'	5.5'	6'	6.5'	7'	7.5'	8'	8.5'	9'
Total Hgt wo/cap	0.000	0.000	0.444	0.444	0.500	0.889	0.917	0.972	1.528	1.667	2.444	2.667	2.889	3.750	4.028	4.306	5.500
Grid Sq Yd per Ln Ft	-	-	4.00	4.00	4.50	8.00	8.25	8.75	13.75	15.00	22.00	24.00	26.00	33.75	36.25	38.75	49.50
Grid total depth	2.40	3.60	4.80	6.00	7.20	8.40	9.60	10.80	12.00	13.20	14.40	15.60	16.80	18.00	19.20	20.40	21.60
Sq Ft Block/Ln Ft	1.00	1.00	1.00	1.00	1.00	1.00	1.00	1.00	1.00	1.00	1.00	1.00	1.00	1.00	1.00	1.00	1.00
# Cap per Ln Ft																	

See "Material Estimating" for Adhesive estimate

CASE O

- "CASE O" Retaining Wall:**
- Flat Ground at Top of Wall
 - 2/1 Slope at Bottom of Wall
 - No Surcharge on Wall

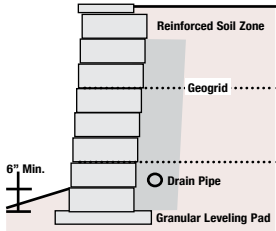

IF STAMPED ENGINEERING IS REQUIRED FOR THIS RETAINING WALL: THIS DESIGN MUST BE STAMPED HERE BY A LICENSED ENGINEER.

GEOGRID PLACEMENT

Note: Grid measurements start from the face of the wall.

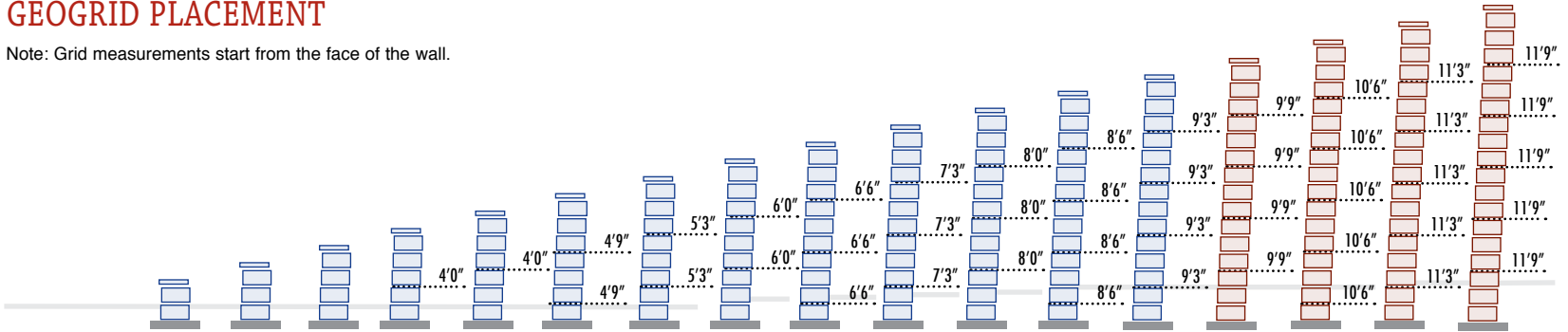

Geogrid Type	SRW Universal - or - SRW 3 Series Grid														SRW 3 Series Grid ONLY			
	0'6"	1'0"	1'6"	2'0"	2'6"	3'0"	3'6"	3'11"	4'4"	4'9"	5'2"	5'7"	6'0"	6'6"	6'11"	7'4"	7'9"	
Exposed Hgt wo/cap	0'6"	1'0"	1'6"	2'0"	2'6"	3'0"	3'6"	3'11"	4'4"	4'9"	5'2"	5'7"	6'0"	6'6"	6'11"	7'4"	7'9"	
Amount Buried	6"	6"	6"	6"	6"	6"	6"	7"	8"	9"	10"	11"	1'0"	1'0"	1'1"	1'2"	1'3"	
Total Hgt wo/cap	1.0'	1.5'	2'	2.5'	3'	3.5'	4'	4.5'	5'	5.5'	6'	6.5'	7'	7.5'	8'	8.5'	9'	
Grid Sq Yd per Ln Ft	0.000	0.000	0.000	0.444	0.444	1.056	1.167	1.333	2.167	2.417	2.667	3.778	4.111	4.333	5.833	6.250	6.528	
Grid total depth	-	-	-	4.00	4.00	9.50	10.50	12.00	19.50	21.75	24.00	34.00	37.00	39.00	52.50	56.25	58.75	
Sq Ft Block/Ln Ft	2.40	3.60	4.80	6.00	7.20	8.40	9.60	10.80	12.00	13.20	14.40	15.60	16.80	18.00	19.20	20.40	21.60	
# Cap per Ln Ft	1.00	1.00	1.00	1.00	1.00	1.00	1.00	1.00	1.00	1.00	1.00	1.00	1.00	1.00	1.00	1.00	1.00	

See "Material Estimating" for Adhesive estimate

CASE P

- "CASE P" Retaining Wall:**
- Flat Ground at Top of Wall
 - 2/1 Slope at Bottom of Wall
 - 100 psf Surcharge on Wall

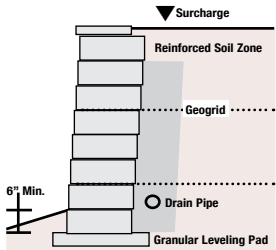

IF STAMPED ENGINEERING IS REQUIRED FOR THIS RETAINING WALL: THIS DESIGN MUST BE STAMPED HERE BY A LICENSED ENGINEER.

GEOGRID PLACEMENT

Note: Grid measurements start from the face of the wall.
• 100 psf Surcharge is light traffic i.e. car or pickup

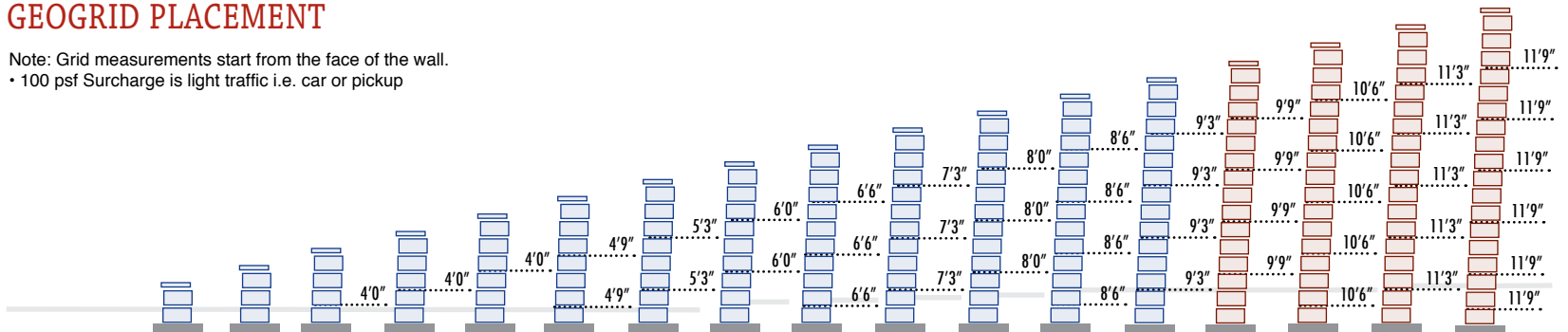

Geogrid Type	SRW Universal - or - SRW 3 Series Grid														SRW 3 Series Grid ONLY			
	0'6"	1'0"	1'6"	2'0"	2'6"	3'0"	3'6"	3'11"	4'4"	4'9"	5'2"	5'7"	6'0"	6'6"	6'11"	7'4"	7'9"	
Exposed Hgt wo/cap	0'6"	1'0"	1'6"	2'0"	2'6"	3'0"	3'6"	3'11"	4'4"	4'9"	5'2"	5'7"	6'0"	6'6"	6'11"	7'4"	7'9"	
Amount Buried	6"	6"	6"	6"	6"	6"	6"	7"	8"	9"	10"	11"	1'0"	1'0"	1'1"	1'2"	1'3"	
Total Hgt wo/cap	1.0'	1.5'	2'	2.5'	3'	3.5'	4'	4.5'	5'	5.5'	6'	6.5'	7'	7.5'	8'	8.5'	9'	
Grid Sq Yd per Ln Ft	0.000	0.000	0.444	0.444	0.444	1.056	1.167	1.333	2.167	2.417	2.667	3.778	4.111	4.333	5.833	6.250	7.833	
Grid total depth	-	-	4.00	4.00	4.00	9.50	10.50	12.00	19.50	21.75	24.00	34.00	37.00	39.00	52.50	56.25	70.50	
Sq Ft Block/Ln Ft	2.40	3.60	4.80	6.00	7.20	8.40	9.60	10.80	12.00	13.20	14.40	15.60	16.80	18.00	19.20	20.40	21.60	
# Cap per Ln Ft	1.00	1.00	1.00	1.00	1.00	1.00	1.00	1.00	1.00	1.00	1.00	1.00	1.00	1.00	1.00	1.00	1.00	

See "Material Estimating" for Adhesive estimate

Geogrid: SRW Universal 635 LTDS or SRW 3 Series 1093 LTDS • Block Dimensions: 6"(H) x 8", 10" OR 12" (W) x 10"(D) • Avg Cover: .4167 Sq.Ft.

If used without the stamped engineering, the final determination of the suitability of the contemplated use, and its manner of use, are the sole responsibility of the user, and the user expressly releases HTS, SRW, and retaining wall unit supplier of any and all liability that might arise as a result. These designs have been performed with National Concrete Masonry Association (NCMA) software and have been analyzed for the appropriate factors of safety. © 2009 Hardscape Technical Services • Maytrx® is a registered trademark of Maytrx Premier Stone System.



32 DEGREE SOIL for walls up to 8'

Maytrx® Block • SRW Accessories

32 DEGREE SOIL for walls up to 8'

Maytrx® Block • SRW Accessories

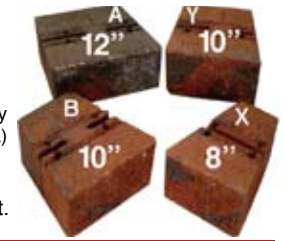

If used without the stamped engineering, the final determination of the suitability of the contemplated use, and its manner of use, are the sole responsibility of the user, and the user expressly releases HTS, SRW, and retaining wall unit supplier of any and all liability that might arise as a result. These designs have been performed with National Concrete Masonry Association (NCMA) software and have been analyzed for the appropriate factors of safety. © 2009 Hardscape Technical Services • Maytrx® is a registered trademark of Maytrx Premier Stone System.

Geogrid: SRW Universal 635 LTDS or SRW 3 Series 1093 LTDS • Block Dimensions: 6\"/>

CASE Q

- “CASE Q” Retaining Wall:**
- Flat Ground at Top of Wall
 - 2/1 Slope at Bottom of Wall
 - 250 psf Surcharge on Wall

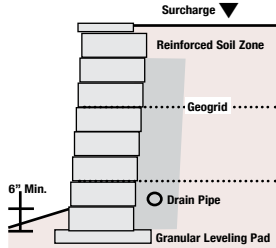

IF STAMPED ENGINEERING IS REQUIRED FOR THIS RETAINING WALL: THIS DESIGN MUST BE STAMPED HERE BY A LICENSED ENGINEER.

GEOGRID PLACEMENT

- Note: Grid measurements start from the face of the wall.
- Surcharge begins two feet behind wall facing.
 - 250 psf Surcharge is heavier traffic i.e. RV, large vehicle

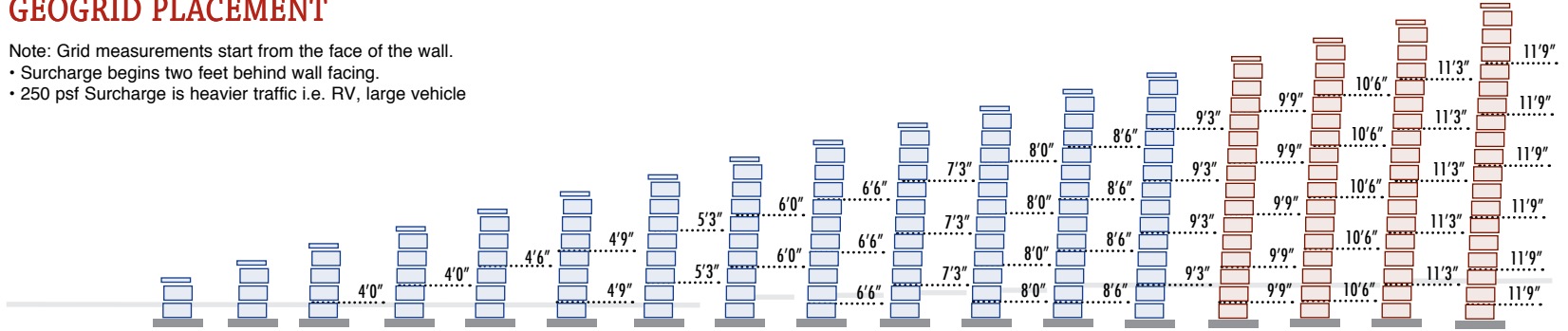

Geogrid Type	SRW Universal - or - SRW 3 Series Grid														SRW 3 Series Grid ONLY			
	0'6"	1'0"	1'6"	2'0"	2'6"	3'0"	3'6"	3'11"	4'4"	4'9"	5'2"	5'7"	6'0"	6'6"	6'11"	7'4"	7'10"	
Exposed Hgt wo/cap	6"	6"	6"	6"	6"	6"	7"	8"	9"	10"	11"	11"	1'0"	1'0"	1'1"	1'2"	1'3"	
Amount Buried	1.0'	1.5'	2'	2.5'	3'	3.5'	4'	4.5'	5'	5.5'	6'	6.5'	7'	7.5'	8'	8.5'	9'	
Grid Sq Yd per Ln Ft	0.000	0.000	0.444	0.444	0.500	1.056	1.167	1.333	2.167	2.417	3.556	3.778	4.111	5.417	5.833	7.500	7.833	
Grid total depth	-	-	4.00	4.00	4.50	9.50	10.50	12.00	19.50	21.75	32.00	34.00	37.00	48.75	52.50	67.50	70.50	
Sq Ft Block/Ln Ft	2.40	3.60	4.80	6.00	7.20	8.40	9.60	10.80	12.00	13.20	14.40	15.60	16.80	18.00	19.20	20.40	21.60	
# Cap per Ln Ft	1.00	1.00	1.00	1.00	1.00	1.00	1.00	1.00	1.00	1.00	1.00	1.00	1.00	1.00	1.00	1.00	1.00	

See “Material Estimating” for Adhesive estimate

section three: INSTALLATION

section three: INSTALLATION

- block specificationsC•2
- wall layout, excavation.....C•3
- protection of soilsC•4
- leveling pad.....C•5
- lay first courseC•6
- backfill & compacting.....C•7
- stepping & additional coursesC•8
- capping & filter fabricC•9
- geogridC•10-11
- curves.....C•11-12
- cornersC•13-14
- drain pipe..... C•15



INSTALLATION

Maytrx® block specifications

The Maytrx multi-use, multi-stone system is the prescription for retaining walls, stone fences, steps, columns and many other projects that display the character of natural stone installations.

The Maytrx system has five stones of different sizes and shapes. All five stones have two faces on each stone allowing projects to be built that require a finished look on both sides of walls, such as stone fences.

The Maytrx A, B, X, and Y stones are 10" deep. Stones faces vary from 12" wide by 6" tall to 4" wide by 6" tall. The cap stone is 11" deep. It is 12" wide and 3" tall and may be used within retaining wall projects as well as used as a cap stone. Also, the A stone and cap Stone may be set on end as a soldier in many wall projects.

NOTE: In some regions Maytrx stones are nominalized to 98.44% of standard dimensions.

For retaining wall specifics such as construction of columns, stairs, pinning/connecting, splitting, corner blocks, etc. refer to the manufacturers website www.maytrx.com.

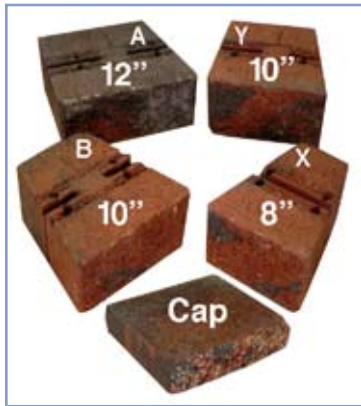

stone "A"

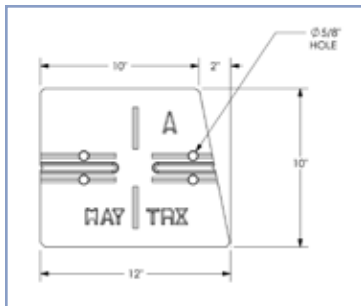

stone "B"

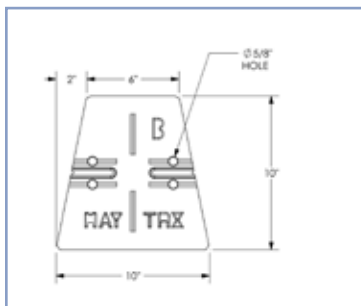

stone "X"

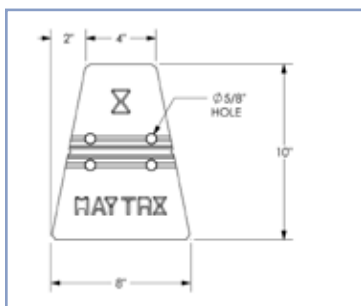

stone "Y"

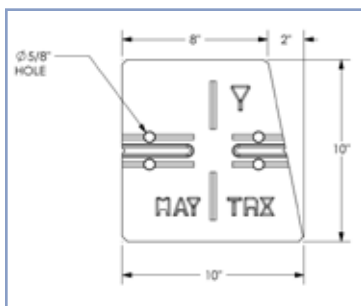

INSTALLATION

retaining wall layout

- Make sure that all components of the retaining wall and excavation are within property boundaries and construction easements.
- Mark the bottom area of the retaining wall with stakes and/or spray paint. Best practice is to offset stakes 5-10 feet from the proposed wall face so the reference points will stay intact during excavation.
- Measure from the marked area to the edge of the leveling pad and mark with spray paint and/or stakes.
- In a cut situation, measure to the back of the excavation, taking into account the amount of slope and/or benching; determined by OSHA safety requirements and local building codes. Mark this area with spray paint and/or stakes.

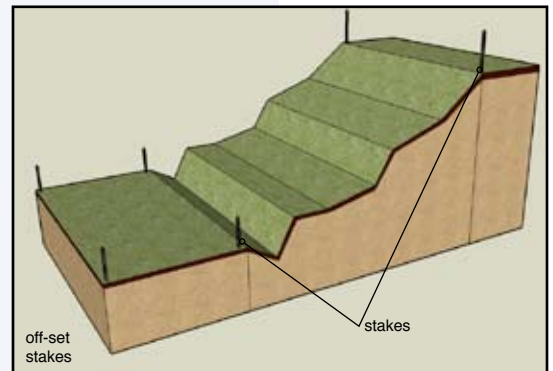

excavation

- Minimum leveling pad DEPTH is 6 inches. That is measured from the bottom of the first layer of proposed retaining wall units.
- Minimum leveling pad WIDTH (front to back) is 6 inches in front and 6 inches in back of the proposed retaining wall unit. Example: For a 12 inch deep retaining wall unit, from face to back, the minimum leveling pad width is 2 feet. However, because the unit is not always placed exactly in the middle of the leveling pad, it is recommended that leveling pad be 6" to 12" wider than the minimum requirement.
- The minimum BURIED DEPTH of the first row of retaining wall units is 6 inches. The typical minimum number of units buried for this program is one block. However, on walls with slopes at the bottom of wall the design may call for more than one unit to be buried. See the design tables for the correct buried depth.
- Excavate cuts to a safe slope or benching as determined by OSHA or local building codes.
- Excavate back, from the face of the wall, to the end of the longest geogrid length, as indicated by your design table.

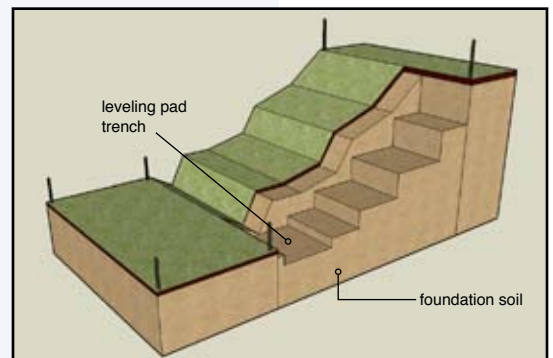

URGENT!
CALL BEFORE
you dig!

Before excavation, see the "call before you dig" instructions in Section 1: Planning.

INSTALLATION

» protection of soils

A proper moisture content is required to achieve proper compaction. Foundation soils and all fill soils should be protected from rain and freezing during construction. Frozen soils must NOT be used in retaining wall construction.

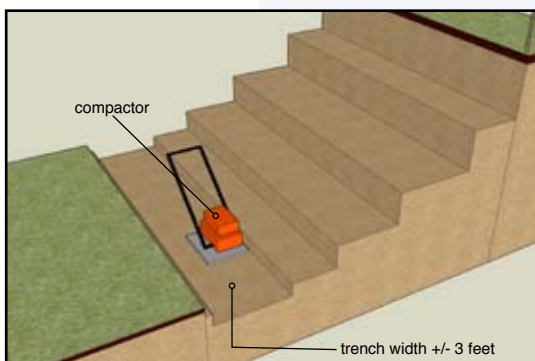

compact sub base

- Compact the soils under the leveling pad to 95% “Standard Proctor Density” (see “Soil Compaction” on page D•6) or greater.
- If organic soils are encountered they must be removed and replaced with acceptable soils.

base stabilization*

- The purpose of the leveling pad is to provide a level surface to place the first course of units on. More importantly, the leveling pad spreads out the load of the retaining wall units over a larger area. The strength and quality of your retaining wall depends greatly on the strength and quality of your leveling pad materials.
- Over time the sub-base material can migrate into the leveling pad, thus contaminating it and diminishing its structural integrity. Base stabilization fabric (SRW SS5) separates the leveling pad materials from the sub-base materials so that its strength will not be compromised.

* Optional, but recommended.

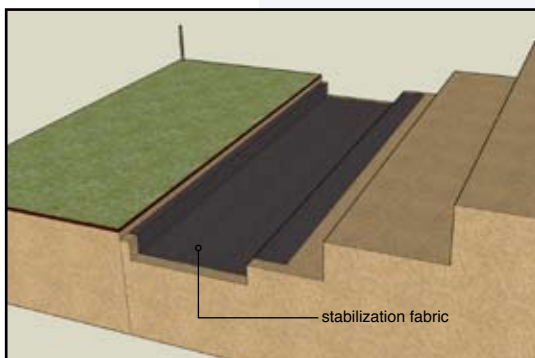

TIP:

This may, or may not, be the proper time to install the drain pipe (see the drain pipe guidelines on page C•15).

INSTALLATION

leveling pad

- If possible, start the leveling pad at the lowest elevation of the wall. It is easier to step up than to step down.
- Place well graded gravel or drainage aggregate in the leveling pad trench (see “Excavation” section for minimum leveling pad depths).
- Compact leveling pad to 95% Standard Proctor Density (see “Soil Compaction” on page D•6) or greater.

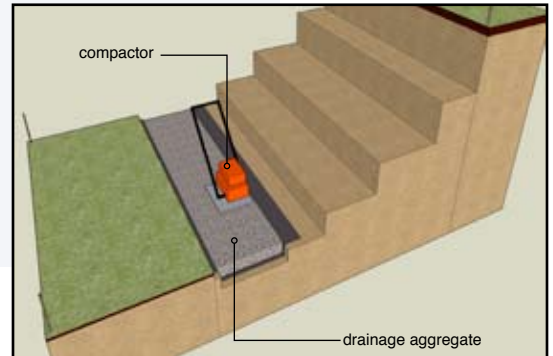

screeding leveling pad

- Place screed pipes across the compacted leveling pad (see illustration).
- If a 10 foot screed is used, an 8 - 9 foot separation of screed pipes works well on straight walls. Screed pipes may need to be closer on curves or corners.
- Make sure the top of the screed pipes are at the correct bottom of the proposed block elevation and are level.
- Place the finish leveling pad material. (If more than 1½" is required, do the compaction again.)
- Screed the leveling pad material smooth, being careful that the screed pipes stay level and at the correct elevation.
- Repeat the screeding operation for the length of the leveling pad, or if the wall steps up, to the 1st step of the leveling pad.
- Do not walk on or otherwise disturb the leveling pad prior to laying the first course of retaining wall units.

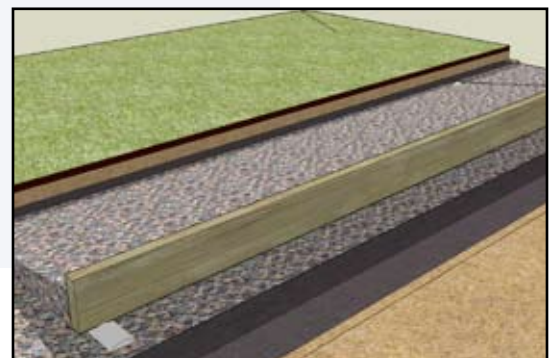
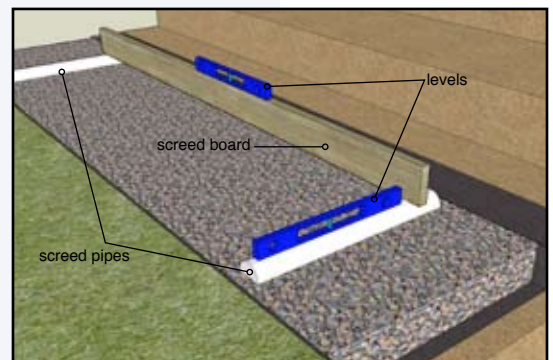

INSTALLATION

laying first course

- Use steel stakes and a string line to lay out straight sections of the retaining wall.
- String lines should be placed so that they go along the BACK of the block in order to ensure a straight line. As opposed to the rock face surface on many retaining wall units. (Double-faced stones can be visually eyed for straightness.)
- If the string line is placed at the correct elevation it can be used to check elevation and side to side levelness of the retaining wall unit.
- For laying out a retaining wall that curves, flexible 3/4" PVC pipe works well. See illustration for staking. See curve and corner guide-lines beginning on page C-11.
- It is very important that the 1st course of block is laid correctly because it will determine the alignment of the rest of the retaining wall. Any deviations will be magnified as the height of the wall increases.
- It is usually best to start at the lowest elevation of the retaining wall. Again, it is easier to step up than to step down.
- If the bottom of the retaining wall unit has lugs, lips, or any other protrusions, use a hammer and chisel to break them off.
- Carefully place the unit on the screeded leveling pad, using the string line (for straight walls) or the flexible PVC pipe (for curved walls) as alignment guides.
- NEVER let the unit touch the string, because if each unit touches the string it will gradually push it out of alignment, which will result in a crooked wall. A good distance from the string is 1/16 - 1/8 inch away.
- For outside or convex curves, if the retaining wall unit has wings at the back of the unit they may be broken off to facilitate tighter curves.
- Always check the level of the retaining wall units, front to back, side to side, and the elevation in relation to the adjacent units.

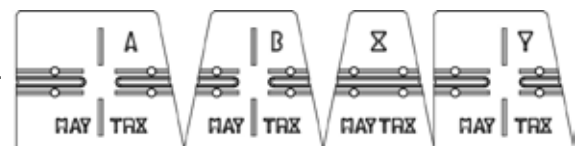
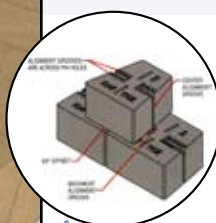
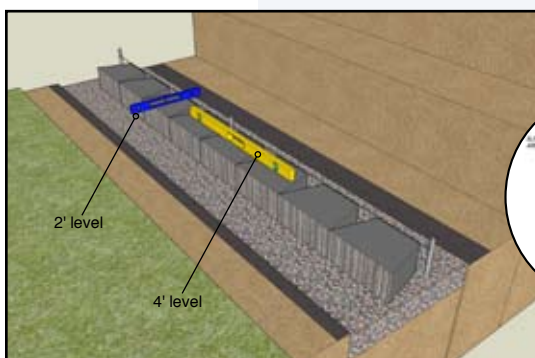
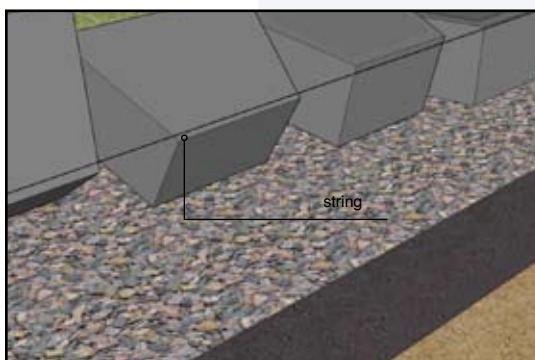
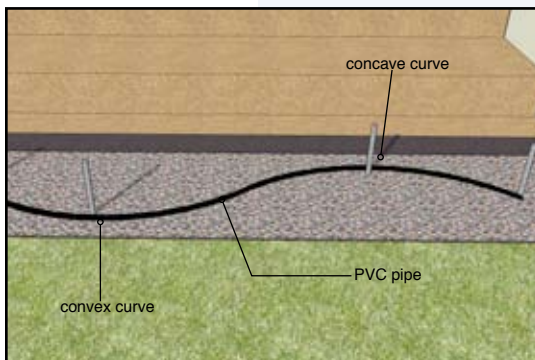
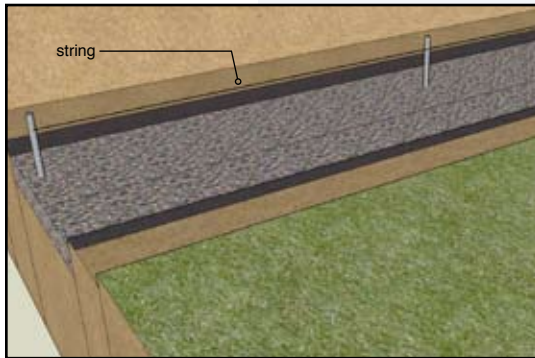

INSTALLATION

backfill and compacting

- Always backfill and compact in 6 - 8" lifts, as each course of block is installed. Do NOT stack two or more courses and backfill in deeper lifts because it will be difficult, if not impossible, to achieve proper compaction.
- Place the backfill, leaving a minimum of 12 inches of space between the retaining wall unit and the backfill, for the drainage aggregate (1/2" to 3/4" angular gravel with a minimum of 5% fines).
- Compact the backfill to 95% Standard Proctor Density (see "Soil Compaction" on page D•6) or better.
- Keep heavy compaction equipment (or any surcharge) at least 3 feet away from the retaining wall units. Lighter, walk-behind compaction equipment can be within the three foot area.
- Compact soil nearest the retaining wall units first, then work toward the back of the excavation.
- Clean out the 12 inch space behind the retaining wall unit with a shovel.
- Place the drainage aggregate behind and in between the retaining wall units and compact. (This sequence minimizes the tendency of units to tip forward during the compaction process)
- Drainage aggregate doesn't take as much force to compact correctly as the backfill material.
- If the retaining wall units have cores or openings, fill them with the drainage aggregate.
- Any backfill placed at the bottom (front) of the retaining wall should be compacted.

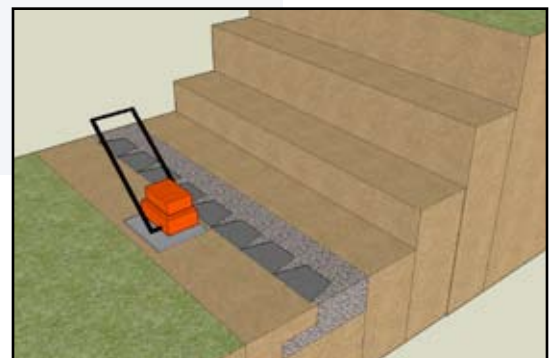
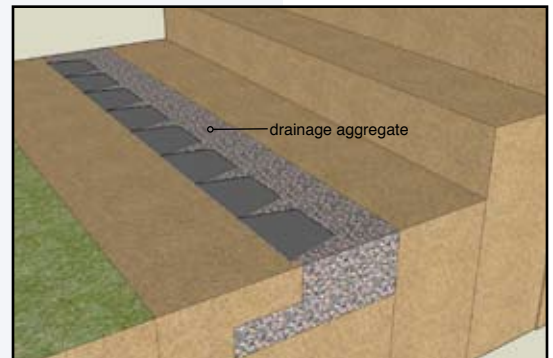
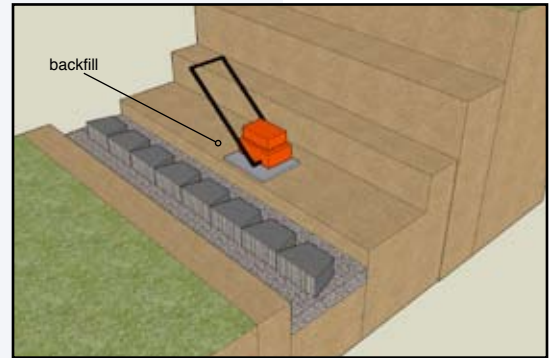

INSTALLATION

elevation changes (stepping)

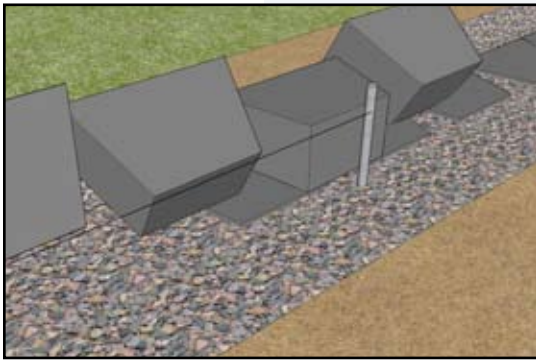
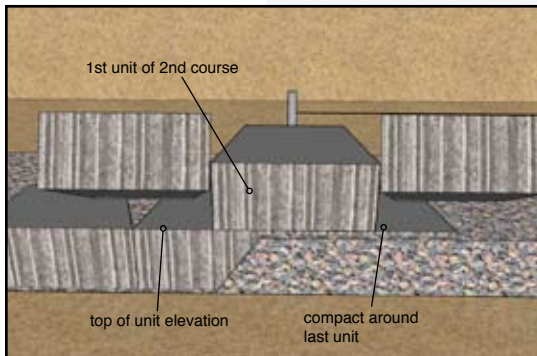

- The top of the first course unit will be the elevation of the leveling pad. Add 1/8 - 1/4 inch extra, to allow for a little settlement.
- Make sure the soil is compacted in and around the last couple of units in the first course.
- Prepare the stepped up leveling pad as previously instructed for base leveling pad.
- Place the first unit of the stepped up course upon the last and second to last unit of the first course (straddling in a half bond fashion).
- Place the second unit of the step up on the last unit of the first course, 1/2 on that unit and 1/2 on the stepped up leveling pad.

» **If geogrid is NOT going to be used, continue on to *additional courses* below.**

» **If geogrid IS going to be used, skip to page C•10 for installation guidelines before continuing on to *additional courses*.**

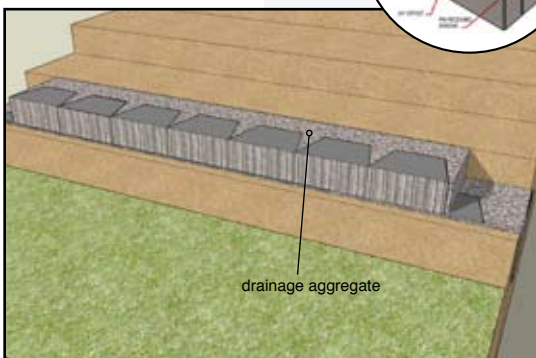
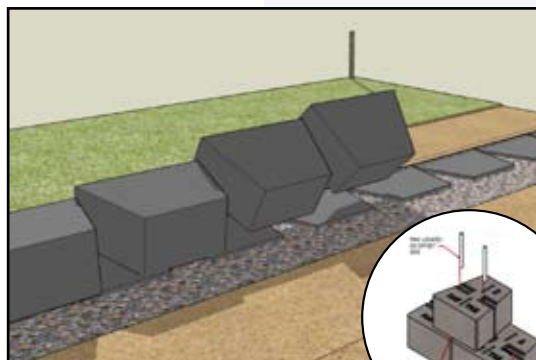

additional courses

- Retaining wall units are connected by lugs, lips, pins, clips, or keyways, which align the units, provide unit to unit shear connection, and provide the automatic setback (otherwise known as batter).
- Sweep any drainage aggregate or soil off the top of the retaining wall units.
- Install the pins or clips, if required by the retaining wall system. Note, some systems will have the pin placed after the upper unit is placed.
- Place the upper unit by straddling the 2 units below in a “half bond” fashion. (See manufacture suggestions on multi-stone systems.)
- Slide the unit forward, towards the face of the wall, engaging the connection device.
- Continue to install each course of retaining wall units; backfill and compact; place drainage aggregate; and core fill to the top of wall elevation.

INSTALLATION

capping

- Clean the top of the retaining wall units of all rock, dirt, and dust.
- Place a bead of adhesive (use *SRW Retaining and Paver Adhesive*) around the top of the last retaining wall unit.
- Place the cap on the retaining wall units. Note: A string line can be used to help line up the caps and straighten any waves that may have developed in the retaining wall.
- If a special cap unit is not used, bond the top course to the course just below.

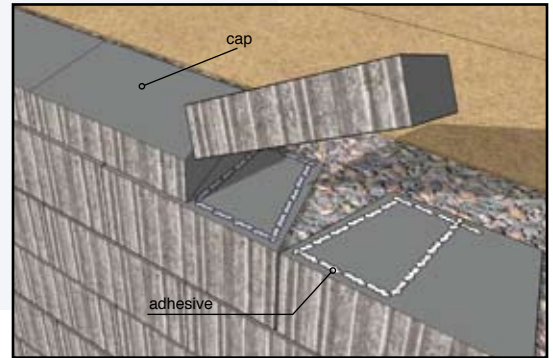

filter fabric*

- Place filter fabric (*SRW NW4.5*) on top of the backfill; over the drainage aggregate; and up against the top units or caps before placing the top/planting soils.
- It is recommended that the top/planting soils should be an 8 inch layer of impermeable soils.
- The filter fabric will help prohibit the migration of the fines from the planting soil down into the drainage aggregate and out the face of the retaining wall, thus preventing the plugging of the drainage aggregate and staining of the wall face.

* Optional, but recommended.

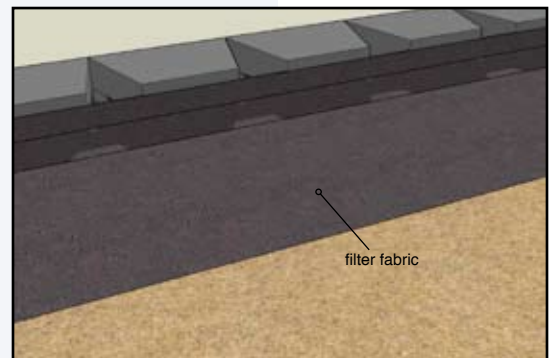

final steps of building the wall

- When finishing the project make sure that the final grade, both the top and bottom of the wall, are shaped so as to divert any water runoff away from the retaining wall. Protect the planting soil from erosion during heavy rains.

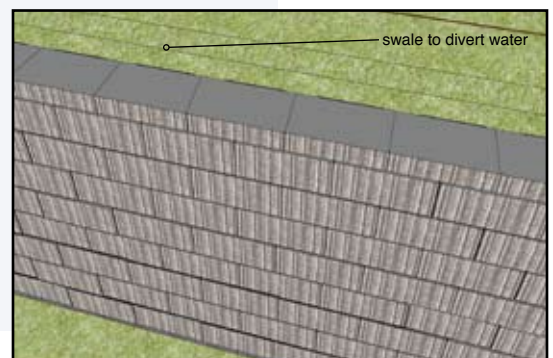

INSTALLATION

» geogrid

All installation instructions are the same as for gravity retaining walls EXCEPT for the addition of geogrid. Geogrid reinforces the soil, thus allowing taller walls to be constructed. SRW Universal and SRW Series 3 geogrids are bi-directional/bi-axial geogrids, meaning the geogrid is the same strength in both directions. Because of that, this geogrid can be either rolled out parallel to the retaining wall or perpendicular to the retaining wall. If the geogrid depths are the same as the roll width, it may be more efficient to roll out the geogrid parallel to the retaining wall. If the geogrid depths called for are different than the roll width or if the wall curves, it is best to roll out the geogrid perpendicular to the retaining wall. (Not all geogrids are bi-axial, most stronger geogrids must be rolled out perpendicular to the retaining wall.)

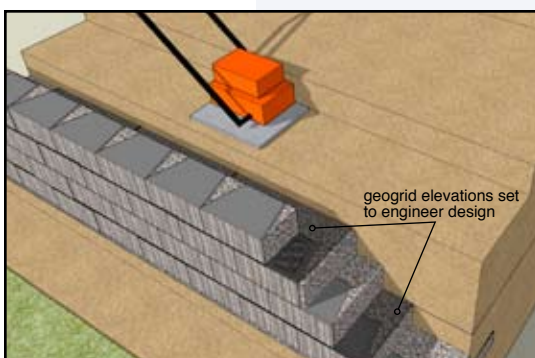
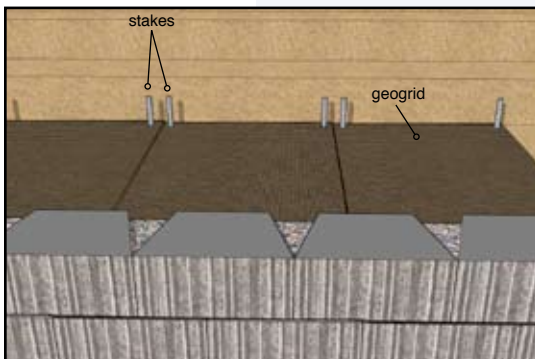
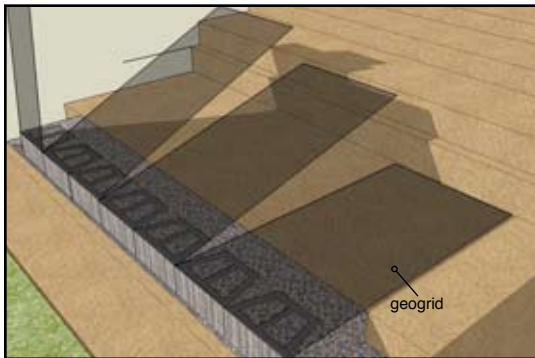

using geogrid

- Geogrid depth is measured from the face of the retaining wall unit, to the back of the reinforced soil.
- Geogrid coverage should be 100%. However, the edges of the geogrid, should NEVER overlap or be spliced from front to back. (See the end of this section for curve and corner geogrid installation procedures.)
- Use your design table(s), found in Section 2 of this guide to determine which course(s) of block to install the geogrid on and how deep it extends into the reinforced soil.
- Place the geogrid as far forward on the retaining wall unit as possible without it showing through the front/face of the retaining wall. Make sure that any connecting devices are engaged by the geogrid.
- Lay the geogrid flat from the wall units to the tail of the geogrid. The backfill, drainage aggregate, and core fill should be level with the top of the retaining wall unit and the geogrid should be as smooth as possible, with no pockets that would create voids under the geogrid.
- Place the next course of block on top of the geogrid and fill the cores with drainage aggregate, if applicable.
- Pull the geogrid taught, being careful not to pull the units back away from the connecting device or disturb the alignment of the units. Use landscape staples or stakes to hold the geogrid in place.

» continued on next page

INSTALLATION

using geogrid (continued)

- Do not drive or compact directly on the geogrid. A minimum of 6 inches of soil is recommended to protect the geogrid.
- When backfilling over the geogrid, work the soil from near the retaining wall units toward the tail of the geogrid. When compacting over the geogrid, work from near the retaining wall units toward the tail of the geogrid. This procedure helps keep the geogrid taught.
- See the curve and corner instructions below, for geogrid placement.

continue building wall

- Continue building the retaining wall by returning to “additional courses” on page C-8.

convex • outside • curves

- To achieve desired curve alignment, use 3/4" flexible PVC pipe to outline the back of your retaining wall unit location. This will give you a guideline to help achieve smooth and accurate curves.
- If possible, it is best to start building a curve from the center of the curve and work outward in both directions.
- Start at the same location for all additional courses of retaining wall units.
- If the unit has wings at the back of the block, one or both may be broken off to achieve a tighter radius.
- Because of the batter (unit setback), the bottom course radius will be larger than the radius of the top course. The taller the wall the larger the bottom course radius needs to be in relation to the top course radius.

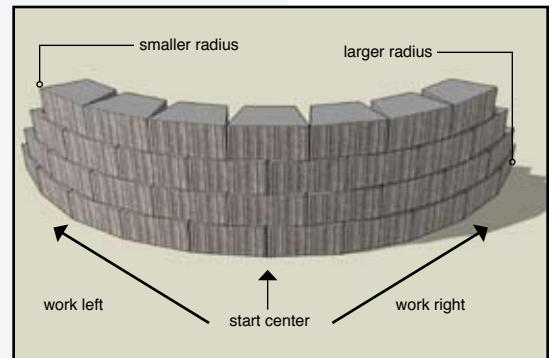
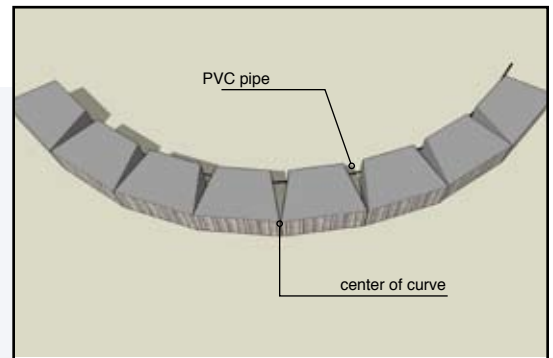

convex curve geogrid placement

- Geogrid coverage should be 100% butted together, but NOT overlapped on the retaining wall units.
- The geogrid tail, starting just behind the unit will be overlapped. A minimum of 3 inches of soil must be placed between these overlapping geogrid layers.

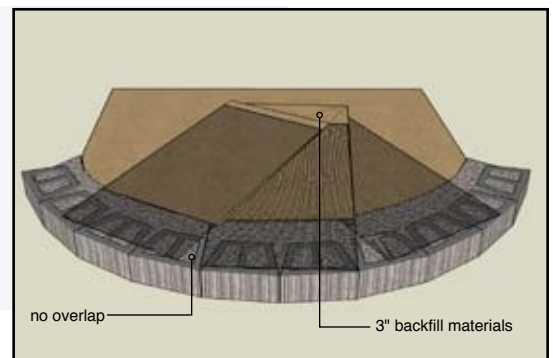

INSTALLATION

concave • inside • curves

- To achieve desired curve alignment, use 3/4" flexible PVC pipe to outline the back of your retaining wall unit location. This will give you a guideline to help achieve smooth and accurate curves.
- If possible, it is best to start building a curve from the center of the curve and work outward in both directions.
- Start at the same location for all additional courses of units.
- Because of the batter (unit setback) the bottom course radius will be smaller than the radius of the top course. The taller the wall the smaller the bottom course radius will be in relation to the top course radius.

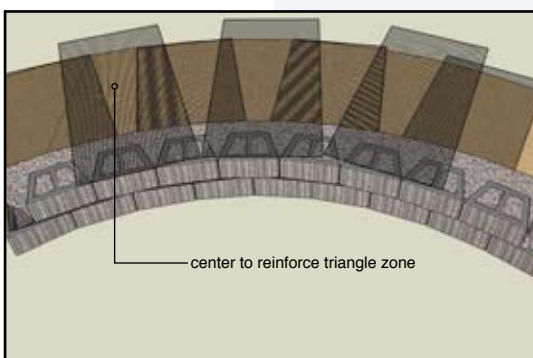
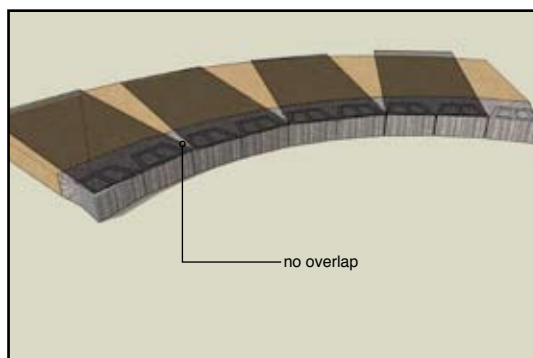
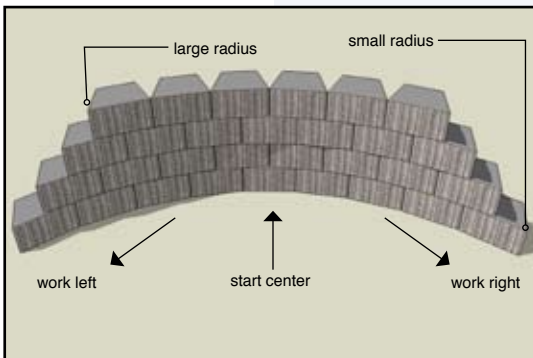
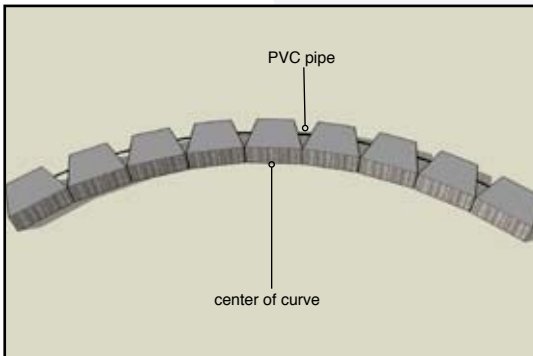

concave curve geogrid placement

- Geogrid coverage should be 100% butted together, but NOT overlapped on the retaining wall units.
- There will be a V or pie shaped wedge of soil starting just behind the units which will not be reinforced. To compensate for the unreinforced section, on the next course of retaining wall units, geogrid is placed by centering over the pie shaped wedge of unreinforced soil below.

INSTALLATION

outside 90° corner

- Lay the corner according to the retaining wall system instructions. Some systems will have special corner units, some will have hand splitting lines, and others will require cutting.
- Each course is usually laid opposite of the course below.
- Where connecting devices cannot be used on corner blocks be sure to keep the same batter (setback) as the rest of the retaining wall.
- Outside corners should be bonded with adhesive (SRW Retaining Wall and Paver Adhesive) where connecting devices are unable to be used.

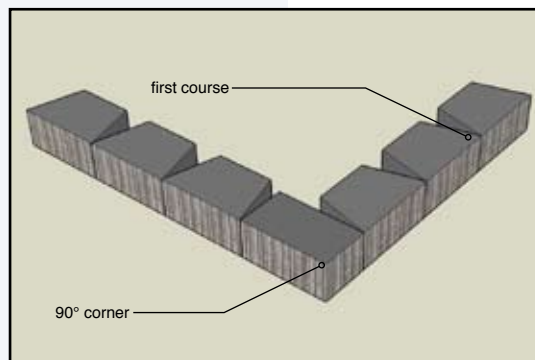

outside corner SRW geogrid placement

- SRW Universal and SRW Series 3 geogrids are bi-directional (same strength in both directions).
- Place the geogrid in the corner so that it goes across the top and towards the front of the units (just far enough so that it will not be seen out of the face of the retaining wall).
- If the geogrid is as wide or wider than the geogrid depth called for in the tables, one layer of SRW geogrid will reinforce the soil in both directions. Other unidirectional SRW geogrids would require an extra layer on the next course in a similar manner as is done on a concave curve.
- If the geogrid is not as wide as the depth called for in the tables, place grid on the next course in the opposite direction to compensate for the lack of proper depth in the layer below.

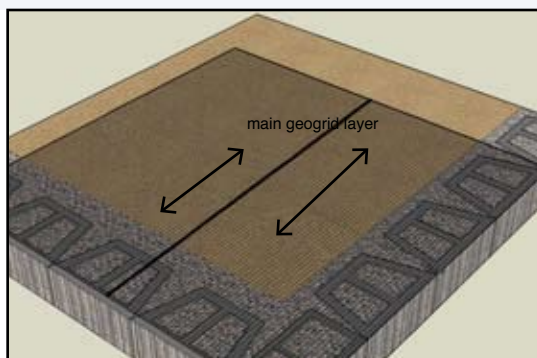
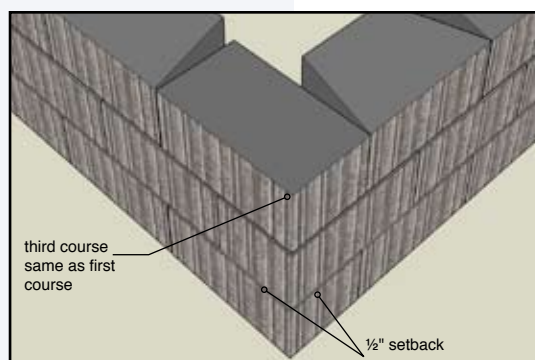
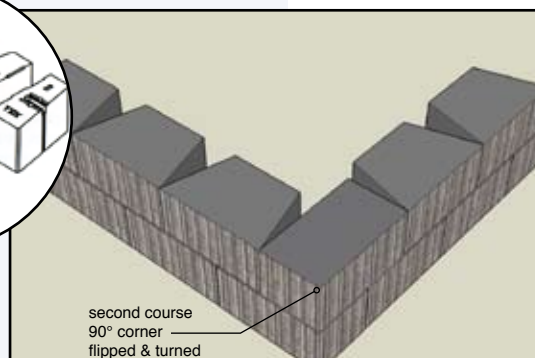
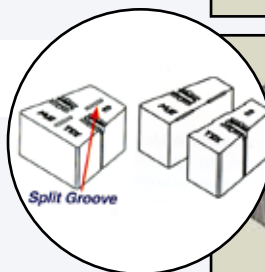

First geogrid layer

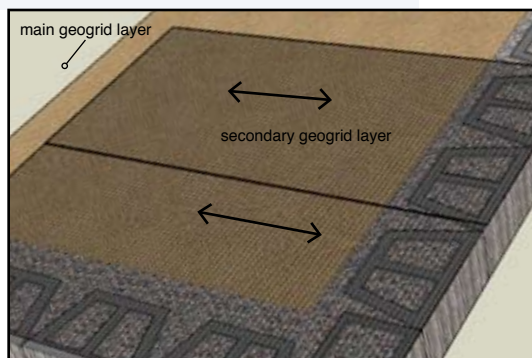

Second geogrid layer

INSTALLATION

inside 90° corner

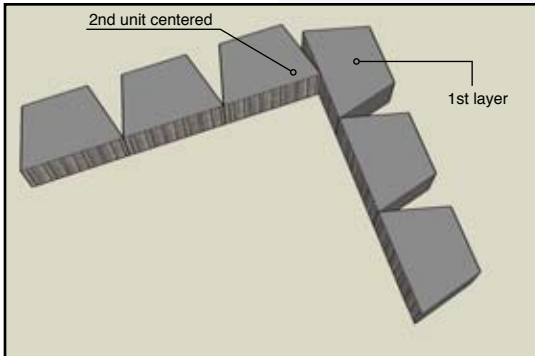

- On the first course, place the face of the first unit of the 90 degree corner at the center of and against the last unit of the wall that the corner is turning from (see illustration).
- On the second course start the corner in the opposite manner with the first unit being laid straddling the 90 degree corner.
- That unit must be set with the same amount of batter (set back) and slid into the corner the same distance as the batter (set back) for each course.
- The 90 degree unit must be placed against the face of the corner unit.
- Repeat the above steps, alternating the corner units so that they are woven together, forming the 90 degree corner.

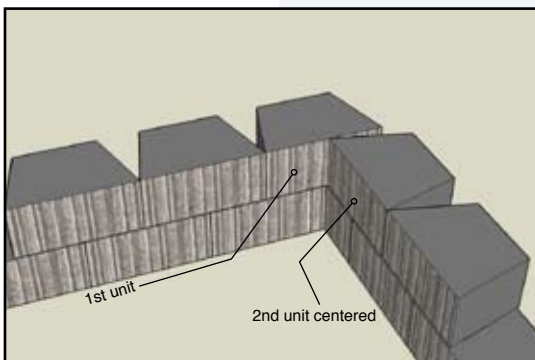
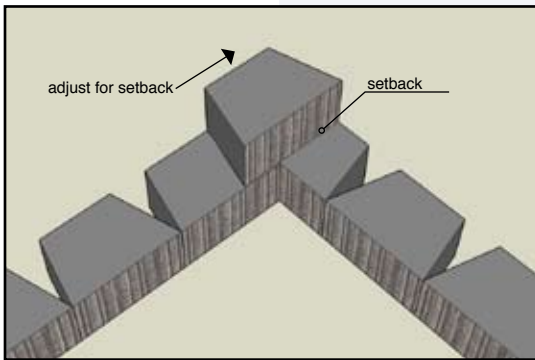

inside curve geogrid placement

- The first layer of geogrid should extend past the corner a distance which equals the height of the retaining wall divided by 4 ($\text{Height of Wall} \div 4$).
- The second layer of geogrid is laid, butting to the 1st layer.
- Per your design table, when the next layer of geogrid is required, that layer of geogrid, on the other leg of the corner, should extend past the corner a distance which equals the height of the retaining wall divided by 4. ($\text{Height of wall} \div 4$)
- Continue to alternate the geogrid extending past the corner on every other layer.

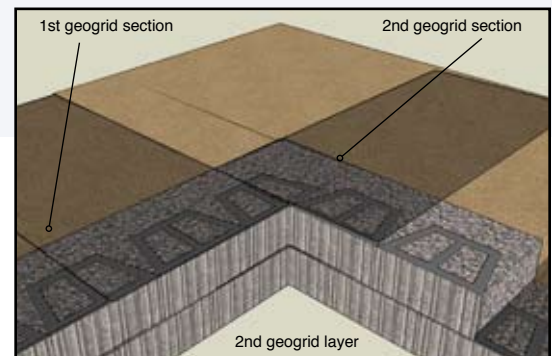
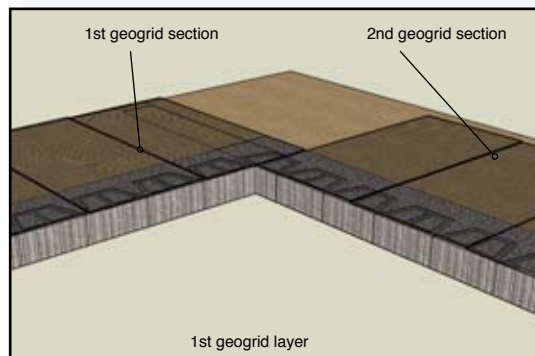

INSTALLATION

» drainage pipe specifications

- The drain pipe should be a minimum diameter of 4 inches.
- The drain pipe must be sloped in order for gravity to direct the water to an outlet.
- Drain pipe outlets can be under the wall units, through the wall units or out the end of the retaining wall. An outlet must be placed at the lowest point of the retaining wall and a minimum of every 50 feet. The drain pipe must be sloped so water can gravitate out of the pipe.

drain pipe outlet (under/out end)

- Drainage aggregate is used for the leveling pad.
- The drainage aggregate chimney extends down to the leveling pad.
- The drain pipe is placed in the leveling pad directly under the drainage aggregate chimney.
- The outlets are either T'd out under the retaining wall units and daylight out of the slope in front of the retaining wall and/or the drain pipe daylights out of the end of the wall.

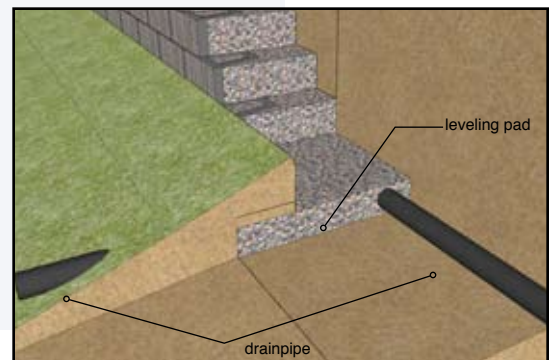

drain pipe outlet (thru face of wall/out end)

- The leveling pad material can either be well graded gravel or drainage aggregate
- Impervious soil (soil that water will not pass through such as road-base) is placed over the leveling pad and extends to the back of the excavation; between the units; in the unit cores (if applicable); and in front of the retaining wall units, up to the finish grade elevation at the bottom (front) of the retaining wall.
- The drain pipe is placed at the bottom of the drainage aggregate chimney. The drain outlets are T'd out the face or out the end of the retaining wall.
- A notch will need to be cut in the bottom of the retaining wall unit for the outlet to exit through.

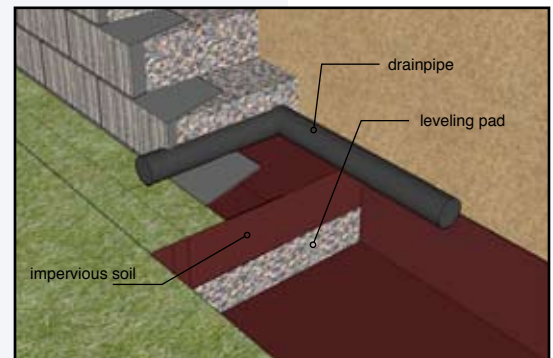

section four: RESOURCE

section four: RESOURCE

- tool/supply checklist..... D•2
- quality checklists..... D•3-4
- soil compaction D•5-6
- water management D•7

- glossary.....D•8-11



TOOLS/SUPPLY LIST SUPPLIES

necessary supplies/tools

- Square Shovel
- Spade Shovel
- 2 Foot Level
- 4 Foot Level
- String Line
- Steel Stakes
- Screed Pipes
- Wheel Barrow
- Rake
- Straight Edge or Screed Board
- Spray Paint
- Rubber Mallet
- Small Sledge Hammer
- Large Sledge Hammer
- Pick
- Diamond Saw
- Compactor 400-500 Lb. Plate
- Caulking Gun
- Flex Pipe for curves
- Snips
- Utility Blade
- Chipping Hammer
- Chalk or Pencil
- Measuring Tape
- Small Tools and Wrenches
- Hearing Protection
- Eye Protection
- Gloves
- Dust Mask
- Hand Compactor
- Garden Hose
- Broom
- Masonry Chisel
- Whisk Broom
- Digital Camera
- Trowel
- Square
- Wall Unit
- SRW geogrid
- Stabilization Fabric

optional supplies/tools (for larger projects)

- Laser Level
- Bobcat
- Excavator
- Easy Level Screeding Tools
- Block Carrying Handle
- SRW geogrid Cutting Table
- Wall Unit Guillotine Splitter
- Density Testing Tools
- Diamond Table Saw
- Jumping Jack
- Diamond Grinder
- Concrete Mixer
- Ride on Compactor
- Large Landscape Rake
- 100' Tape

CHECKING QUALITY INSPECTION CHECKLIST SITE QUALITY INSPECTION

This inspection list is a tool that can be used by Owners, Contractors, Inspectors and Engineers as a quality control guide for the retaining wall project prior to and during installation. This list will help assure that construction is in accordance with design tables, installation guidelines and specifications. Not only should the inspection review all aspects of the structural quality but also the quality of the aesthetics of the project. It is recommended that photos are taken to document the project from start to finish. The photos should be taken at each step of the project as follows:

1. Trench for leveling pad
2. Leveling pad completion
3. At each course of block
4. At each layer of compacted backfill
5. At each layer of installed geogrid
6. The finished project

The following checklists are a tool to help assure that all aspects of the retaining wall project are properly performed. Not all items in this check list will be applicable for all projects.

» PRIOR TO CONSTRUCTION VERIFY

- ☉ Site design drawings and specification documents
- ☉ Utility location details
- ☉ Site elevation grading details
- ☉ List of project products and attached specifications
- ☉ Qualified engineered stamped designed package
- ☉ During construction site water control plan

» GENERAL EXCAVATION

- ☉ Locate and mark all utilities, etc. before starting excavation
- ☉ Call local gas companies before excavation
- ☉ Excavation of base leveling pad and wall reinforced zone meets construction drawings and specifications
- ☉ Excavated back-cut has been terraced to follow engineer

specifications or in accordance to OHSa requirements (site specific exceptions may apply if approved by engineer)

- ☉ All water issues that have been uncovered due to excavation for the wall have been addressed and taken care of.

» SITE SURVEY

- ☉ Locations and elevations of all stakes should match construction drawings
- ☉ Each base elevation change should have corresponding stake
- ☉ Foundation soils should match or exceed design assumed types and strengths
- ☉ Retained soils should match or exceed design assumed types and strengths
- ☉ Site soils should not be frozen
- ☉ Wall heights do not exceed design
- ☉ Slopes above and below wall do not exceed design
- ☉ Loading should not exceed design
- ☉ Site water conditions should match the design

» FOUNDATION SOILS AND PREPARATION

- ☉ The sub-grade soils meet the minimum requirements as by the specified soil type.
- ☉ Any sub-grade soils that are unsuitable have been removed and replaced.
- ☉ The replaced or disturbed sub-grade soils must be compacted to 95% Standard Proctor Density.
- ☉ All changes have been documented and noted on the construction drawings

CHECKING QUALITY INSPECTION CHECKLIST SITE QUALITY INSPECTION

» BASE LEVELING PAD

- ⊙ Base leveling pad gravel is as specified in installation guidelines.
- ⊙ The base leveling pad depth and width is in accordance with installation guidelines.
- ⊙ The compaction density meets the requirements of the specifications.
- ⊙ The base leveling pad is level horizontally and back to front.
- ⊙ The minimum burial depth of the base leveling pad at each elevation base change and that the location meet construction drawings.
- ⊙ The base stabilization fabrics installation is in accordance to the installation guidelines.

» DRAINAGE/UNIT INFILL

- ⊙ Drainage gravel should be 1/2 to 3/4 inch clear crush gravel with no fines
- ⊙ Clear crush gravel should be filled into all unit voids and a minimum of 12 inches behind the units
- ⊙ Unit voids should be filled no more than one (1) course at a time
- ⊙ Perforated drainage pipe (if needed) should be sloped properly and daylight at proper intervals

» GEOSYNTHETIC REINFORCEMENTS

- ⊙ All reinforcements should be placed in the correct orientation.
- ⊙ Reinforcements should be placed at the proper horizontal levels in the wall.
- ⊙ Reinforcements should be of correct length as shown on design.
- ⊙ Reinforcements should be properly connected to the units.
- ⊙ Reinforcements should be properly tensioned before backfilling retained soils.
- ⊙ Equipment should not be driven on the reinforcement.
- ⊙ Reinforcements installed in curves, corners or other special applications should follow the design details or as per geosynthetic manufacturer's specification.

» GEOSYNTHETIC FABRICS

- ⊙ Geosynthetic fabrics should be used as per installation guidelines.

» BLOCK UNITS

- ⊙ The delivered and installed units are the same as indicated on the construction drawings and specifications. The unit size, color, and dimension tolerances meet or exceed the minimum requirements.
- ⊙ Units are level side to side and front to back.
- ⊙ Units are placed tightly to each other.
- ⊙ Units setback and alignment should be checked and corrected on each row.
- ⊙ All units are sound and free of cracks or other defects.
- ⊙ All unit connectors should be properly engaged

» REINFORCED SOILS

- ⊙ Soils should not be frozen.
- ⊙ Soils should be at ultimate moisture (not too dry or too wet).
- ⊙ Soils should be compacted in lifts not greater than 6-8 inches and to 95% Standard Proctor or greater.
- ⊙ Soils on SRW geogrid layers should be flat and level to the top of the units.
- ⊙ Soils should be placed and compacted to 95% Standard Proctor at the front or toe of wall to the design wall burial depth.

» TOP OF WALL UNITS

- ⊙ Cap units as per design
- ⊙ Capping units should be adhered to the last row of units using SRW adhesives and with adequate surface adhesive coverage

» ABOVE AND BELOW WALL FINISH GRADING

- ⊙ Final grades should meet design plans heights and tolerance
- ⊙ All grades, slope lengths and drainage swales should be in accordance to the design
- ⊙ Temporary erosion controls should be in place until final surface treatments have been established

GENERAL INFORMATION ABOUT COMPACTION

SOIL COMPACTION

Compaction increases the density or unit weight of the soil, mechanically forcing air and water out of spaces between soil particles. Soils that are well-compacted will be able to support heavy loads without settling. This load bearing capacity is necessary to support sub-soils, base levelling pads, and backfill materials. High density soil compaction is critical for long term support for the weight of the wall, and any structures above the wall such as parking lots, roads, storage yards, and buildings.

factors influencing soil density

TO REACH THE ACCEPTABLE DENSITY LEVEL:

- Soils must have the correct compaction potential. Some soils will never reach acceptable levels, and others will need a lot of compaction energy to meet the required standard.
- The moisture content determines how well the soil compacts. Soils with the correct amount of moisture need less compaction energy.
- The type of machinery to compact the soil varies to accommodate different soil types and the scale of the project. The most effective mechanical compaction methods are ramming and vibration.
- The rate at which a compaction machine can compact the soil depends on the balance between the height it achieves, and the speed it can repeat the action. Compaction machines have ratings which indicate the height (amplitude) and speed (frequency) of operation to achieve optimum compaction density. This rating can vary depending on the type of machine and the kind of soil or conditions.
- When the soil is near or at maximum density, the compaction machine's amplitude (the height it jumps) increases, giving a good visual indication of completion.

note:

When granular and clay soils are mixed, the machine used should be suitable for the soil that represents the largest percentage of the combined material.

choosing the proper compaction equipment

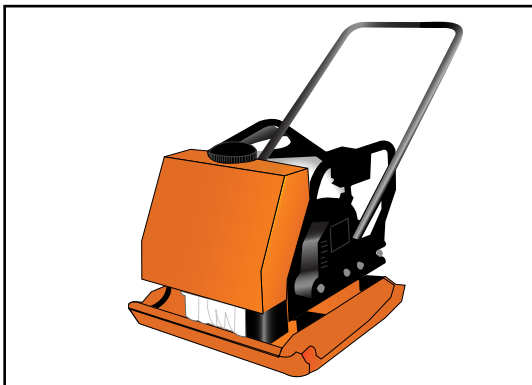

VIBRATION: Machines such as vibratory plate or vibratory roller compactors are best used to compact granular (gravel and/or sands) soils. Vibratory plate or vibratory roller compactors have high frequency and low amplitude. These soils have little or no cohesion and can be best compacted through vibration.

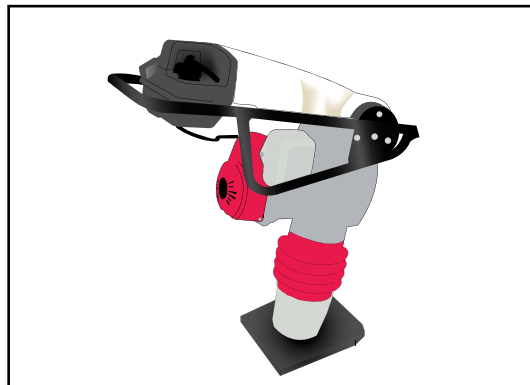

RAM/IMPACT: Machines such as ramming plate compactors, jumping jacks, ramming rollers with or without sheepsfoot protrusions are best used to compact cohesive (clay) soils. Ram/impact machines have low frequency and high amplitude.

GENERAL INFORMATION ABOUT COMPACTION

SOIL COMPACTION

compaction and lift heights

Soils are compacted into layers called lifts. The depth of the lift should not be greater than the compaction machine can handle. Loose soil is placed in these lifts or layers, compacted, and then another layer of loose soil is added. These steps continue until all the backfill materials have been compacted to finished grade.

Compaction starts from the bottom of the lift and gradually works its way to the surface where the machine is riding. The impact wave from the machine travels through the soil, down to the hard surface of the preceding lift, and then returns upward, setting the particles in motion. As the soil becomes compacted, the impact has a shorter distance to travel so that more force returns to the machine, making the machine bounce higher off of the ground. The deeper the lift of the soil, the longer it will take to compact the materials to the correct compaction density.

Each type of soil has a different lift-depth ratio for maximum compaction, and the machines have a wide range of lift-height capabilities. Ask your compaction machinery dealer for the correct specifications on the machines available for your project.

soil testing for compaction

The most common testing procedures for measuring density of soils:

- **STANDARD PROCTOR TEST**
- **MODIFIED PROCTOR TEST**

These laboratory tests determine the maximum density and optimum moisture content ratings for a particular type of soil or soil mixture.

The on-site Nuclear Test is the most accurate way of testing the soil density and moisture content after compaction. In the Nuclear Test, a hand-held Geiger probe using gamma rays from a radioactive source is inserted into the soil.



standard proctor test

The Standard Proctor Test is performed in a laboratory on a soil sample from the job site. This sample is divided into three layers, receiving 25 blows per layer. After the wet weight/cubic foot reading is recorded, the sample is then oven-dried for 12 hours to establish the water content.

modified proctor test

The Modified Proctor Test is the same as the Standard Proctor Test, but adds more weight and height to the instrument delivering the blows and increases the layers to five. This test is usually required when testing soils for high-shear strength to support heavier loads.

TIPS FOR WATER MANAGEMENT DURING & AFTER CONSTRUCTION

WATER MANAGEMENT

Water in some form is a factor in a high percentage of retaining wall problems. Water can impart an addition lateral load of as high as 1.5 to 2 times greater than that of soil alone. It is important to identify possible water sources that may affect your retaining wall. Possible water sources may be surface water or runoff, ground water seeping out of the retained soil, or ground water percolating up from the foundation soil. Ground water seeping out of the retained soil or ground water percolating up from the foundation soil will require site specific engineering. External water in the form of ponds or streams in contact with the retaining wall will require site specific engineering as well. Some tips for water management during construction and for finished retaining wall configuration are as follows:

during construction

1. Soil must have the proper moisture content for compactability.
2. At the end of each day, shape the backfill so that water has to run off and will not be allowed to sit and soak in.
3. Depending on the soil type, it may be necessary to cover the backfill soil, both already placed and to be placed, to keep it from becoming saturated in the event of rain.
4. A perforated PVC drain pipe should be placed at the bottom of the 1 foot of drainage aggregate that is just behind the retaining wall units. The drain pipe must be a minimum of 4" in diameter with the perforated holes in the up position.
5. The drain pipe should be sloped such that the water can drain out of the pipe. Water can be drained out at the end of the retaining wall or if the wall is long enough, out the face of the wall. Outlets should be placed at the lowest point of the drainage system and must be a minimum of 50' apart.

after construction

1. Grading at the top of wall should be shaped so as to divert any surface water or runoff away from the retaining wall.
2. A swale could be placed at the top of wall just behind the block that will channel the surface water or runoff away from the retaining wall.
3. If a swale is used, 8" of impermeable soil beneath the swale will keep water exiting the retaining wall area, from seeping down into the reinforced soil mass and causing wall damage.

note:

The above water management suggestions are minimal requirements for water management.

DRAINAGE AGGREGATE GRADATION

SIEVE SIZE	% PASSING
1 inch	100
3/4" inch	75-100
No. 4	0-60
No. 40	0-50
No. 200	0-5

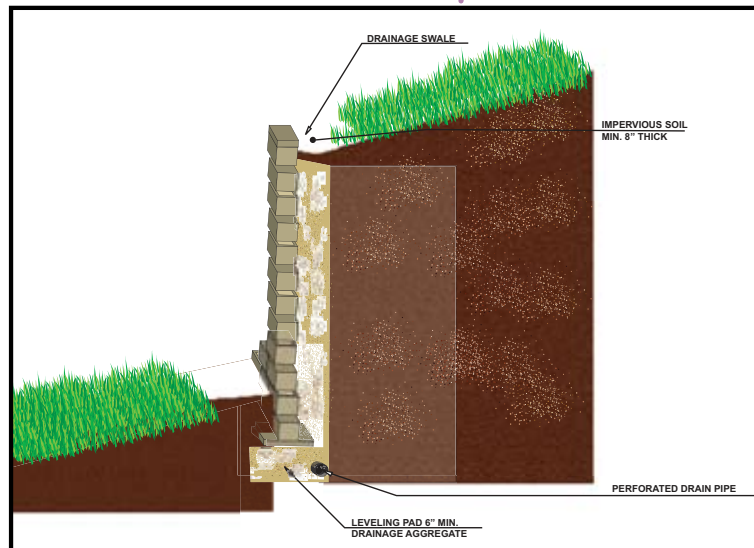

RETAINING WALL TERMINOLOGY GLOSSARY

• a •

Aggregates • Sand, gravel, or crushed rock used in the leveling pad, drainage behind and in the unit cores, concrete or backfill.

Amplitude • The vertical vibration of a roller or plate compactor.

Aspect Ratio • The length ratio of SRW geogrid reinforcing to the height of the wall for an SRW wall system (minimum .6H).

ASTM • The American Society of Testing and Materials is an international standards developing organization that develops and publishes voluntary technical standards for a wide range of materials, products, systems, and services.

• b •

Backfill • Gravel or other material used to replace material removed during construction behind retaining walls.

Backslope • The non-horizontal finish grade of soils behind a wall; typically expressed as horizontal distance to vertical height (H:V backslope); used in engineering calculations, backslope increases the design load on a wall.

Base Course • The base course is the first layer of retaining wall units placed on the leveling pad.

Base Stabilization Fabric • Stabilization fabrics provide a rugged separation layer between aggregate and subgrade. A fabric that provides a separation between two different types of soils, acts as a soil separator and provides structural stability to the gravel leveling pad.

Batter or Setback • A facing angle created by SRW unit setback, measured from a vertical line drawn from the toe of the wall. Batter can be expressed either in degrees or ratio of vertical to horizontal. A leaning of the wall face towards the retained fill is considered a positive batter, while an outward lean is considered a negative batter. Typical batter angles are 3 degrees to 15 degrees from vertical, sloping toward the infill soil. Batter is often built into a wall by off-setting (or “setting back”) successive courses of a wall by a specified amount.

Bearing Capacity • The pressure that a soil can sustain without failing.

Bidirectional or Biaxial SRW geogrid • SRW geogrid that provides the same tensile strength in two directions.

Bond or Half Bond • Blocks laid so that the top block overlaps the bottom block by half of its length.

Burial Depth • (Refer to *Embedment Depth*.)

• c •

Clay • Clay is made of fines with putty like properties and is sticky when wet. Clay soils can be very strong when in a dry state.

Cohesive Soils • Clay or soil with a high clay content, which has cohesive strength. Cohesive soils include clayey silt, sandy clay, silty clay, clay and organic clay.

Compaction • Densification of soil by mechanical means, involving the expulsion of excess air. It is important to compact foundation and backfill soils to prevent future wall movement. Compaction is often accomplished using a hand tamper or a vibratory-plate compactor.

Concave Curves • When facing the wall, a curve that bends toward the viewer like the interior of a sphere.

Concrete Adhesive • A glue used to adhere concrete to concrete such as caps to wall units.

Convex Curves • When facing the wall, a curve that bends away from the viewer like the exterior of a sphere.

Course • A horizontal layer of retaining wall units.

Clear Crush Drain Gravel or Drainage Aggregate • Well-graded crushed aggregates with rock size of 1/2 inch to 3/4 inch that have no fines. This material is used in the hollow core of retaining wall blocks and directly behind the wall.

CSA • Canadian Standards Association

Cut Line • Limit of excavation behind the retaining wall.

• d •

Dead Load • An inert, inactive load, primarily due to the structure’s own weight.

Density • The weight of a concrete unit or compacted soil compared to the unit volume which is expressed as lbs/cubic feet (kg/m)

RETAINING WALL TERMINOLOGY GLOSSARY

Drain Pipe • (Refer to *Perforated Drain Pipe*.)

Drainage System or Chimney • The band of vertical, clear crushed gravel, usually 12 inches wide, behind the retaining wall or in the hollow core, that allows water to flow down freely from the surface to the base of the wall to be carried away by the drainage system.

• e •

Embedment or Burial Depth • The primary benefit of wall embedment is to ensure the SRW is not undermined by erosion of the soil in front of the wall. Increasing the depth of embedment also provides greater stability when site conditions include weak bearing capacity of underlying soils, steep slopes near the toe of the wall, potential scour at the toe (particularly in waterfront or submerged applications), seasonal soil volume changes, or seismic loads.

Excavation • The process of removing soils for the installation of the leveling pad and the backfill reinforced zone of a retaining wall.

• f •

Facing • A generic term given to the face or unit of a retaining wall, used for aesthetic purposes and to prevent the backfill soil from escaping out from between the rows of reinforcement.

Filter Fabric • A textile-like material used in soil drainage. It is usually non-woven or spunbond material.

Fines • Silt and/or clay-sized particles.

Foundation Soils • The portion of soils below the leveling pad and reinforced soil zone that distributes pressure of the retaining wall bearing weight.

Frequency • The number of cycles per minute at which a roller or plate vibrator vibrates at (Hertz)

Friction Angle (Phi) • A measure of the shear resistance of a soil due to the interlocking of soil grains and the resistance to sliding between the grains.

SRW geogrid/Geosynthetic Reinforcement • A textile like material used in soil reinforcement along with soil, rock, earth, or other geotechnical engineering related material as an integral part of a man-made project, structure or system. It is usually comprised of polyester, polyethylene, or polypropylene.

• g •

SRW geogrid length and Spacing • For soil-reinforced segmental retaining walls, geogrid reinforcement increases the mass of the composite SRW structure, and therefore increases the resistance to destabilizing forces. Length of the geogrid is typically determined by external stability calculations. Increasing the length of the geogrid layers increases the SRW's resistance to overturning, base sliding, and bearing failures. In some instances, the length of the uppermost layer(s) is locally extended in order to provide adequate anchorage (pullout capacity) for the geogrid layers. The strength of the geogrid and the frictional interaction with the surrounding soil may also affect geogrid length.

Global Stability • Resistance to overall mass movement of the SRW system in a circular mode. Global stability may be a problem for tiered walls, walls with weak foundation soils and walls with a slope at the top or bottom. The factor of safety against an overall failure of a retaining wall or slope along a deep-seated slip surface passing beneath and behind a structure.

Gradation • A soil sample that passes through a specified sieve size range which is expressed in percentage of the mass.

Grade, Finished • The completed surfaces or elevation of lawns, walks and roads brought to grades as designed above or below the wall.

Gravel or Granular Soil • Granular material or soil made of gravel or sand that does not stick together and can pass through a No. 4 sieve.

Gravity Wall • A retaining wall without soil reinforcement where unit weight alone provides resistance to earth pressures. Gravity walls are generally less than three feet in height and do not support slopes or other loads above the walls.

Groundwater • Generally, all water that is underground as opposed to on the surface of the ground. Usually refers to water in the saturated zone below the water table.

• h •

Height, Total Wall • The vertically measured height of a retaining wall; includes the portion of the wall extending below the ground surface in front of the wall (subgrade).

RETAINING WALL TERMINOLOGY GLOSSARY

Hollow Core • A hollow portion inside the block that provides engineering design flexibility.

• i •

Impermeable Materials or Soils • Materials or soils through which water cannot pass such as clay.

Infill • Soil located behind the SRW units and drainage fill. May be reinforced with soil reinforcement.

Interlock • The transfer of force between one retaining wall unit to another by means of weight or mechanical connection. This resistant is measured by lbs/sq. ft.

• l •

Leveling Pad • The leveling pad is a level surface, consisting of crushed stone or unreinforced concrete, which distributes the weight of the SRW units over a wider area and provides a working surface during construction. The leveling pad typically extends at least 6 in. (152 mm) from the toe and heel of the lowermost SRW unit and is at least 6 in. (152 mm) thick.

Lift • A layer of soil or depth between each compaction process. All compaction equipment has a rate or lift depth at which it can achieve proper soil density. A lift height is typically 6 to 8 inches and should be no more than eight inches.

Live Load • The weight of all non-permanent objects on top of a retaining wall such as vehicles or movable storage items or snow. Live load does not include wind or seismic loading.

Long Term Design Strength (LTDS) • The allowable strength in the soil reinforcement at the end of the service life of the soil-reinforcement SRW. It is taken into account in the design process.

• m •

Moisture Content • The amount of water that soils contain is moisture content. This is measured in % of water to weight of compacted soil.

• n •

NCMA • (National Concrete Masonry Association) Creators of retaining wall design software called NCMA SRWall that is a standard for the segmental retaining wall industry.

Negative Slope • A slope that has an elevation lower than the bottom or toe of the wall.

Nuclear Density Testing • A method or equipment used to accurately test the density/moisture of compacted soils.

• o •

Optimum Moisture Content • The ideal level of moisture present so that soil can be compacted to its maximum density.

Organic Materials • Spongy soils, usually made from vegetative matter, that are not suitable for construction use.

Orientation of SRW geogrid • For unidirectional geogrid, correct alignment of geogrid to wall face. A geogrid's direction of strength should be perpendicular to the wall.

• p •

Padfoot or Sheepsfoot • A roller vibrator that has knob-like protrusions on the drum surface that aids in compacting clayey soils to proper density.

Permeable • The ability of materials, soils or a retaining wall unit to allow water to pass through it.

Perforated Drain Pipe • Flexible or rigid pipe with holes that water can penetrate and drain into.

Plate Compactor • A vibrator plate that is used to compact sand or gravels.

Positive Slope • A slope that has an elevation higher than the top of the wall.

PVC Flexible Pipe • Flexible pipe (3/4 inch), made of plastic or PVC. Used as a guide for curvature of base wall units.

• r •

Reinforced Backfill Materials or Fill • Compacted structural fill used behind soil-reinforced SRW units which contains horizontal soil reinforcement.

Retained Soil • Retained soil is the undisturbed soil for cut walls or the common backfill soil compacted behind infill or reinforced backfill soils.

Reinforced Soil Zone • The area behind the SRW wall that is reinforced by SRW geogrid or other reinforcing systems.

RETAINING WALL TERMINOLOGY GLOSSARY

• S •

Sand • Granular material passing through a No. 4 sieve but is predominantly retained on a No. 200 sieve.

Screed • Process of leveling a gravel leveling pad utilizing a straight edge pulled across set screed pipes.

Screed Board or Straight Edge • A straight board or aluminum straight edge that is pulled across set screed pipes to level the gravel leveling pad.

Screed Pipes • Steel pipes that are placed level across the gravel leveling pad when a straight edge is drawn across to level the leveling pad.

Segmental Retaining Wall (SRW) • A retaining wall, normally comprised of soil or aggregates stabilized by horizontal layers of reinforcement such as SRW geogrids. The facing for such walls generally consists of dry cast concrete blocks. Which are placed without the use of mortar (dry stacked), and which rely on a combination of mechanical interlock and mass to prevent overturning and sliding. By industry convention, SRW walls have face inclinations of 70 to 90 degrees (near vertical). SRW slopes have inclinations of 70 degrees or less.

Setback • The distance that each course is aligned behind the preceding (lower) course.

Shear Capacity • All SRW units provide a means of transferring lateral forces from one course to the next. Shear capacity provides lateral stability for this mortarless wall system.

Silt • Clay or sandy soil particles that pass through the No. 200 sieve (US Standard).

Soil Separation Fabric • Separation fabrics serve as a barrier between fine grain soils and load-distributing aggregate fill material to keep different types of soils from migrating.

SRW - (Refer to *Segmental Retaining Wall*.)

Standard Proctor Density • A test that determines the maximum dry density (typically 95%) for specific soil types. Specified compaction densities for fills are often based on a percentage of Standard Proctor for a specific moisture content

Sub-base or Subgrade • The soil below the base leveling pad of a retaining wall.

Sub-Base Leveling Trench • Trench that contains crushed stone, concrete etc. to create leveling pad.

Surcharge • Weight or load acting in, on, or near a retaining wall that impacts its ability to perform. A roadway or building foundation can be a surcharge. Surcharge loads must be included in the design and engineering of retaining walls.

Swale • A small ditch or depression formed on top and behind the SRW system to collect water and carry it away .

• T •

Tensile Strength • The ability of a material to withstand tension; a term often used as an abbreviation for ultimate tensile stress. It is much higher than the greatest safe stress.

Tiered or Terraced Walls • Two or more stacked walls with each upper wall set back from the underlying wall. Tiered wall designs should be reviewed by a qualified engineer.

Toe of Wall • Front, base portion of a retaining wall.

• U •

Uniaxial or Unidirectional • Having one direction; or relating to or affecting one axis. Having tensile strength in one direction only.

• W •

Well Graded Gravel (GW) • Aggregate materials that have a full range of sizes from dust to the largest rock.

request form:

HTS STAMPED ENGINEERING *for 8' & Under Retaining Walls*

project name	
Property Address	
Property Owner	
Property Phone	
Installer/Company	
Contacts Name	
Address	
City, State, Zip	
Phone and Fax	
Contacts Email	

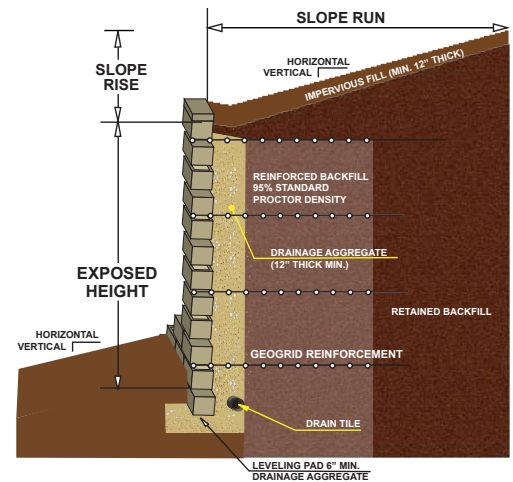

Figure 1

general wall information	
What block do you plan to use?	
What geogrid do you plan to use?	
Company buying materials from?	
Maximum exposed wall height(ft):	
Is this wall project multi-tiered or terraced? <input type="checkbox"/> YES (Please check page I•2 for multi-tier program specs.) <input type="checkbox"/> NO	
Are grading plans available? Plans must show wall placement, elevations, lineal footage with grade lines and/or wall face profiles. If no plans are available, sketches must be provided. <input type="checkbox"/> YES (Include grading plans with this request.) <input type="checkbox"/> NO (See page A•6 for sketch instructions)	
Take photographs of proposed retaining wall site. (See manual page A•8 Photo Instructions)	

Confused?
refer to your
HTS manual
"section one:
PLANNING"

slope information (See manual page A•4 Methods of Slope Determination)	
Is there slope at the TOP of the wall? (Ex: 2 horizontal to 1 vertical; aka 2/1) <input type="checkbox"/> YES <input type="checkbox"/> NO If YES, what is the angle of slope? _____	
Is the slope rise the same or greater than 2x's the height of the wall? (This is the elevataion change from top of wall to top of slope. See figure 1 above.) <input type="checkbox"/> YES <input type="checkbox"/> NO If NO, what is the slope height(ft)? _____	
Is there slope at the BOTTOM of the wall? (Ex: 2 horizontal to 1 vertical; aka 2/1) <input type="checkbox"/> YES <input type="checkbox"/> NO If YES, what is the angle of slope? _____	

surcharge (load) information	
Indicate type of surcharge (load) on top of the wall: <input type="checkbox"/> Lawn/Grass <input type="checkbox"/> Light auto parking/drive (car) <input type="checkbox"/> Heavy vehicle parking/drive (RV)	
Is there any surcharge close to the wall (within a distance of 2x's the walls height)? <input type="checkbox"/> NO <input type="checkbox"/> YES Type of load: _____ Distance from wall(ft): _____	

soils information	
Is there a recent soils report available? <input type="checkbox"/> YES (Include soils report with this request) <input type="checkbox"/> NO (See manual page A•10 Soil Sampling Instructions)	

Continues on back side

request form:

HTS STAMPED ENGINEERING for 8' & Under Retaining Walls

Continued from front side

other proposed project / site variables	
Is there any type (steel, wood, PVC) of fence going on top of the wall? <input type="checkbox"/> YES <input type="checkbox"/> NO	
Are there utilities, or anything else needing to go through the facing or reinforced soil? <input type="checkbox"/> YES <input type="checkbox"/> NO	
Additional Notes:	

send final stamped engineering to		<input type="checkbox"/> Send to Installer address
Attention		
Company		
Address		
City, State, Zip		
Phone and Fax		
Contacts Email		

purchasing information		<i>(Optional: To better serve our dealers/customers)</i>
Where do you plan on purchasing the materials for this project?		
If known, what company manufactured the block you will be using?		
How did you hear about HTS?		

payment information		<i>(HTS accepts the following credit cards or checks)</i>
Card Type	<input type="checkbox"/> VISA <input type="checkbox"/> MASTERCARD	<input type="checkbox"/> Business <input type="checkbox"/> Personal
Account Number		
Exp Date		CID <small>(3-digits on back)</small> <input type="checkbox"/> <input type="checkbox"/> <input type="checkbox"/>
Name on Card		
Billing Address		
City, State, Zip		

PLEASE FILL OUT ALL ITEMS ON THIS FORM: By submitting and signing this form I certify that the information provided herein is accurate and correct. HTS will forward all required information to a licensed and registered engineer in the state of the project. If any site conditions change (e.g. water seepage, soil changes, surcharge changes, or height changes etc.), are encountered, construction of retaining wall must be stopped and Hardscape Technical Services informed of the new conditions before placing ANY retaining wall units. It can then be determined if the stamped designs are appropriate or if changes are required. If your local building authorities accept stamped engineering documentation in a fax or email format, the turn-around time is estimated to be no longer than five working days from the day that Hardscape Technical Services receives ALL the required information (including payment). If embossed (raised) stamping is required by your local building authorities, add the necessary time to return the stamped engineering by means other than electronic.

Information Supplied By:		
Signature and Date:		

checklist:

- For quicker turnaround, make sure form is complete and accurate.
- Complete plans or sketches of site and proposed wall
- Take photos of wall site
- If needed, determine slope
- Get soils report or take sampling of soil
- Is raised stamping required by local authorities? ● Yes

Include with Request Form:

- Plans or sketches
- Photos of wall site
- Soil report or sampling
- Payment information

Send to:

HTS
 PO Box 369
 Princeton, MN 55371

Phone: 866-582-0894
 hts@hardscapetech.com

*Need more information:
 www.hardscapetech.com*